

THIS DRAWING IS UNPUBLISHED. RELEASED FOR PUBLICATION
 © COPYRIGHT BY TYCO ELECTRONICS CORPORATION. ALL RIGHTS RESERVED.

LOC	DIST	REVISIONS			
P	LTR	DESCRIPTION	DATE	DWN	APVD
AD	00	L	EC 0G3C 0195 05	31MAY05	BSV JLG

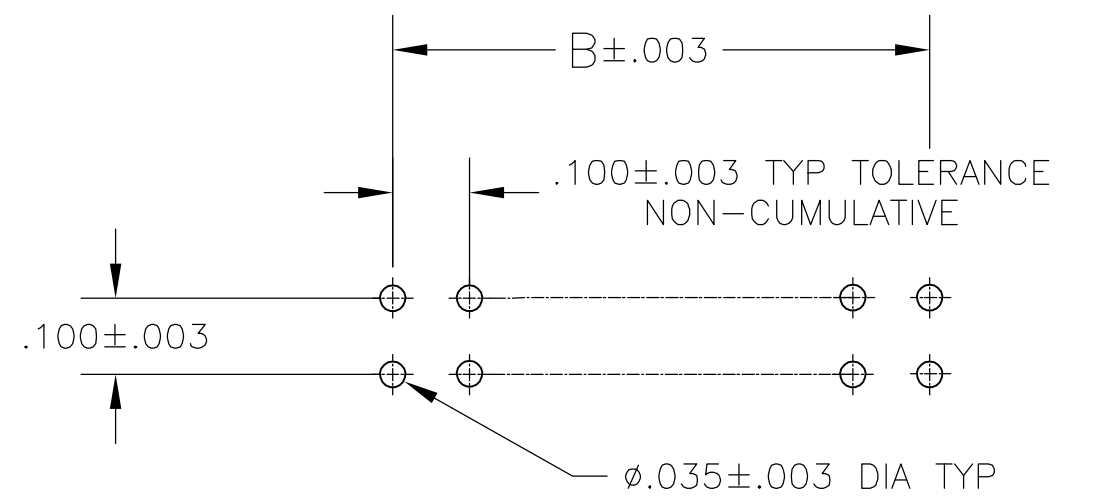
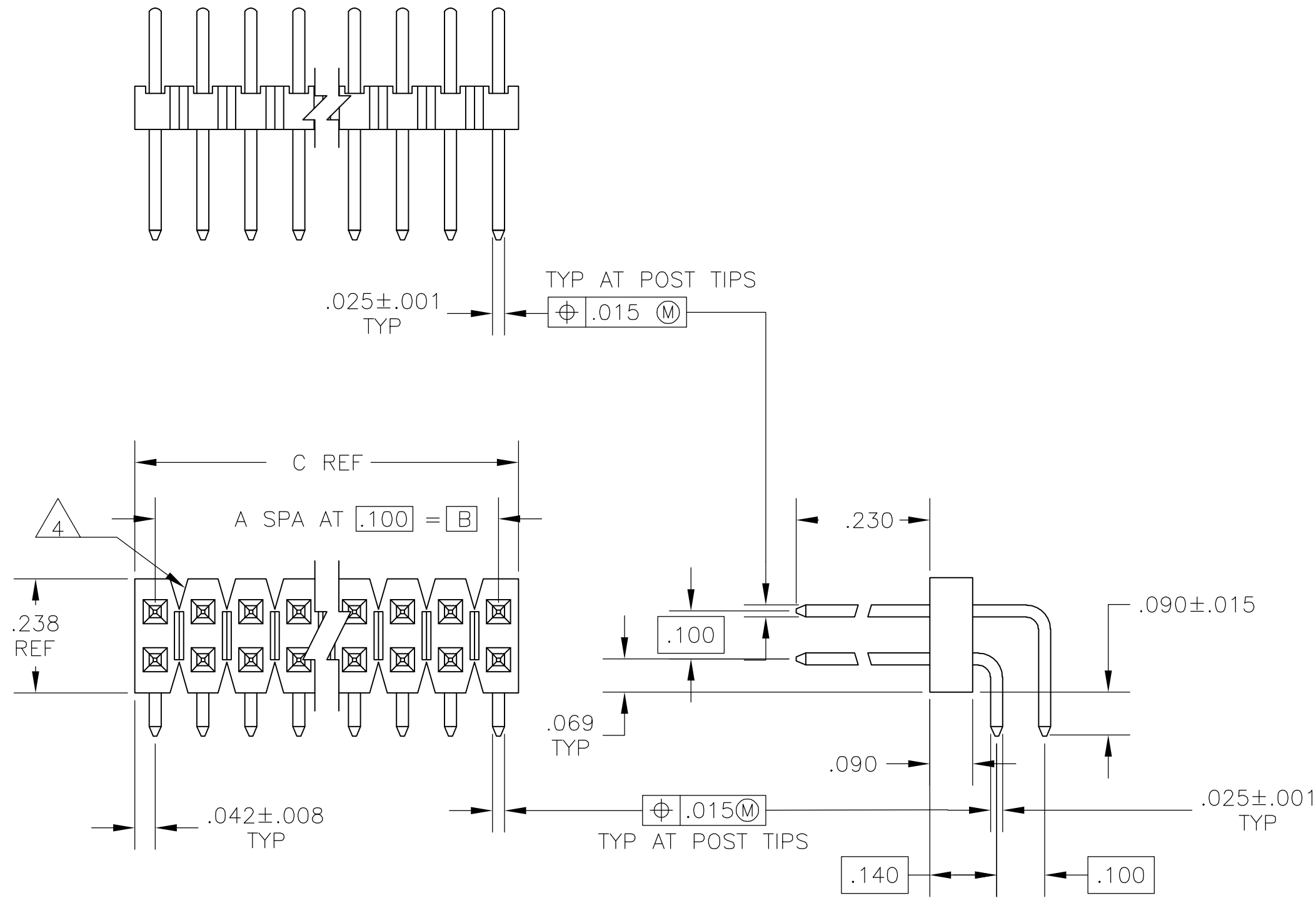

RECOMMENDED HOLE LAYOUT

- 1 ASSEMBLIES MAY BE BROKEN TO THE DESIRED NUMBER OF POSITIONS
- 2 TRUE POSITION TOLERANCE OF THE POST TIPS APPLIES WHEN THE HEADERS ARE HELD FLAT AGAINST THE PRINTED CIRCUIT BOARD
- 3 .000100—.000200 MATTE TIN—LEAD OVER .000050 NICKEL ENTIRE POST
- 4 BREAKAWY NOTCH ANGLE CAN BE ORIENTED TO THE RIGHT (AS SHOWN) OR TO THE LEFT
- 5 .000100—.000200 BRIGHT TIN OVER .000050 NICKEL ENTIRE POST
- 6 PRELIMINARY PART—NOT RELEASED FOR PRODUCTION.
- 7 .000100—.000200 MATTE TIN OVER .000050 NICKEL ENTIRE POST
- 8 HIGH TEMP CONFIGURATION

103795

B

A

THIS DRAWING IS A CONTROLLED DOCUMENT.		DWN L. D. RINGLEY 30JUL85	Tyco Electronics Corporation Harrisburg, Pa 17105-3608	
DIMENSIONS: INCHES		CHK J. GESFORD 27AUG03	NAME ASSEMBLY, MOD II, HEADER, BREAKAWAY, DOUBLE ROW, RIGHT ANGLE, .100X.100 C/L, WITH .025 SQ. POSTS	
TOLERANCES UNLESS OTHERWISE SPECIFIED:		APVD J. GESFORD 27AUG03	PRODUCT SPEC	RESTRICTED TO
0 PLC ± - 1 PLC ± - 2 PLC ± - 3 PLC ± .005 4 PLC ± - ANGLES ± - FINISH SEE TABLE		APPLICATION SPEC	SIZE A2	CAGE CODE 00779
MATERIAL		WEIGHT	DRAWING NO C=103795	SCALE 4:1
-		-	CUSTOMER DRAWING	SHEET 1 OF 2 REV L

THIS DRAWING IS UNPUBLISHED. RELEASED FOR PUBLICATION
 © COPYRIGHT BY TYCO ELECTRONICS CORPORATION. ALL RIGHTS RESERVED.

LOC	DIST	REVISIONS					
AD	00	P	LTR	DESCRIPTION	DATE	DWN	APVD
		-		SEE SHEET 1	-	-	-

REMARKS	PLATING	C	B	A	NO OF POS	ASSEMBLY PART NUMBER	REMARKS	PLATING	C	B	A	NO OF POS	ASSEMBLY PART NUMBER
					2	5-103795-1						2	103795-1
		.184	.100	1	4	5-103795-2						4	103795-2
		.284	.200	2	6	5-103795-3						6	103795-3
		.384	.300	3	8	5-103795-4						8	103795-4
		.484	.400	4	10	5-103795-5						10	103795-5
		.584	.500	5	12	5-103795-6						12	103795-6
		.684	.600	6	14	5-103795-7						14	103795-7
		.784	.700	7	16	5-103795-8						16	103795-8
		.884	.800	8	18	5-103795-9						18	103795-9
		.984	.900	9	20	6-103795-0						20	1-103795-0
		1.084	1.000	10	22	6-103795-1						22	1-103795-1
		1.184	1.100	11	24	6-103795-2						24	1-103795-2
		1.284	1.200	12	26	6-103795-3						26	1-103795-3
		1.384	1.300	13	28	6-103795-4						28	1-103795-4
		1.484	1.400	14	30	6-103795-5						30	1-103795-5
		1.584	1.500	15	32	6-103795-6						32	1-103795-6
		1.684	1.600	16	34	6-103795-7						34	1-103795-7
		1.784	1.700	17	36	6-103795-8						36	1-103795-8
		1.884	1.800	18	38	6-103795-9						38	1-103795-9
		1.984	1.900	19	40	7-103795-0						40	2-103795-0
		2.084	2.000	20	42	7-103795-1						42	2-103795-1
		2.184	2.100	21	44	7-103795-2						44	2-103795-2
		2.284	2.200	22	46	7-103795-3						46	2-103795-3
		2.384	2.300	23	48	7-103795-4						48	2-103795-4
		2.484	2.400	24	50	7-103795-5						50	2-103795-5
		2.584	2.500	25	52	7-103795-6						52	2-103795-6
		2.684	2.600	26	54	7-103795-7						54	2-103795-7
		2.784	2.700	27	56	7-103795-8						56	2-103795-8
		2.884	2.800	28	58	7-103795-9						58	2-103795-9
		2.984	2.900	29	60	8-103795-0						60	3-103795-0
		3.084	3.000	30	62	8-103795-1						62	3-103795-1
		3.184	3.100	31	64	8-103795-2						64	3-103795-2
		3.284	3.200	32	66	8-103795-3						66	3-103795-3
		3.284	3.300	33	68	8-103795-4						68	3-103795-4
		3.484	3.400	34	70	8-103795-5						70	3-103795-5
		3.584	3.500	35	72	8-103795-6						72	3-103795-6
		3.684	3.600	36	74	8-103795-7						74	3-103795-7
		3.784	3.700	37	76	8-103795-8						76	3-103795-8
		3.884	3.800	38	78	8-103795-9						78	3-103795-9
		3.984	3.900	39	80	9-103795-0						80	4-103795-0

THIS DRAWING IS A CONTROLLED DOCUMENT.		DWN	L. D. RINGLEY	30JUL85	 Tyco Electronics Corporation Harrisburg, Pa 17105-3608
DIMENSIONS: INCHES		CHK	J. GESFORD	27AUG03	
TOLERANCES UNLESS OTHERWISE SPECIFIED:		APVD	J. GESFORD	27AUG03	
0 PLC ± - 1 PLC ± - 2 PLC ± - 3 PLC ± .005 4 PLC ± - ANGLES ± - FINISH SEE TABLE		NAME		PRODUCT SPEC	
MATERIAL -		APPLICATION SPEC		WEIGHT -	ASSEMBLY, MOD II, HEADER, BREAKAWAY, DOUBLE ROW, RIGHT ANGLE, .100X.100 C/L, WITH .025 SQ. POSTS
		CUSTOMER DRAWING		SCALE 1:1	RESTRICTED TO
				SHEET 2 OF 2	REV L