

CKT	A	B	SLOTS LOCATION
02	4.93 .194	2.54 ± 0.05 .100 ± .002	NONE
03	7.47 .294	5.08 ± 0.10 .200 ± .004	NONE
04	10.01 .394	7.62 ± 0.15 .300 ± .006	NONE
05	12.55 .494	10.16 ± 0.15 .400 ± .006	NONE
06	15.09 .594	12.70 ± 0.18 .500 ± .007	4, 5
07	17.63 .694	15.24 ± 0.18 .600 ± .007	4, 5
08	20.17 .794	17.78 ± 0.20 .700 ± .008	4, 5
09	22.71 .894	20.32 ± 0.20 .800 ± .008	4, 5
10	25.25 .994	22.86 ± 0.23 .900 ± .009	4, 5
11	27.79 1.094	25.40 ± 0.23 1.000 ± .009	4, 5 8, 9
12	30.33 1.194	27.94 ± 0.25 1.100 ± .010	4, 5 8, 9

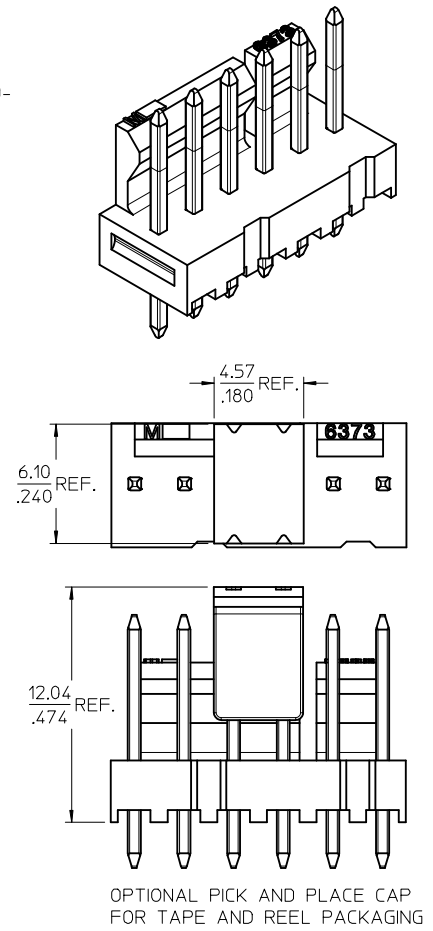
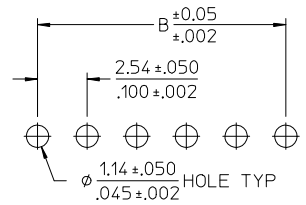
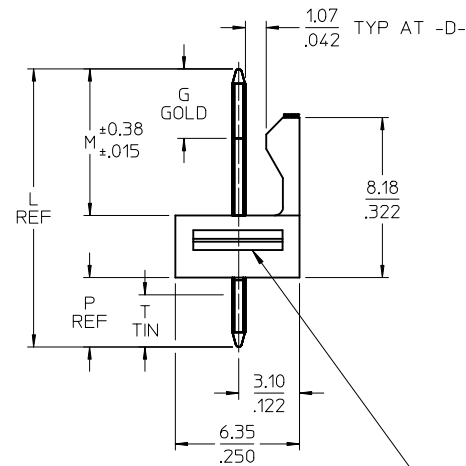
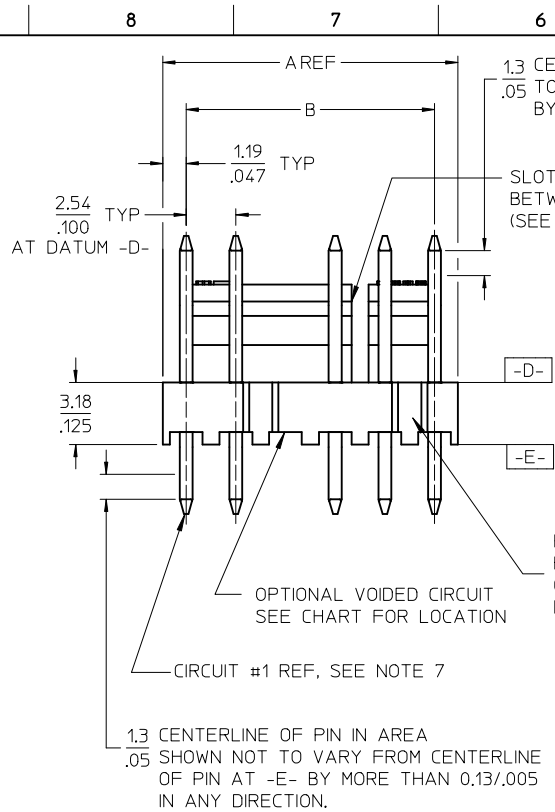

- NOTES:
- MATERIAL: HOUSING: NYLON, UL 94V-2, IEC 60335-1 5TH EDITION GLOW WIRE CAPABLE, COLOR: BLACK
PINS: BRASS
 - FINISH:
(197) = OVERALL REFLOWED MATTE TIN: 0.00152/.000060 MIN OVER 0.00127/.000050 MIN NICKEL.
(208) = SELECT GOLD: 0.00038/.000015 MIN, SELECT MATTE TIN: 0.00254/.000100 MIN, BOTH OVER 0.00127/.000050 MIN NICKEL.
(228) = SELECT GOLD: 0.00076/.000030 MIN, SELECT MATTE TIN: 0.00254/.000100 MIN, BOTH OVER 0.00127/.000050 MIN NICKEL.
 - PRODUCT SPECIFICATION AND PROCESS PARAMETERS: PS-171856-0001, PS-171856-0002
 - PACKAGING INFORMATION: SEE CHART.
 - MATES WITH: 4455, 2695, 6471 SERIES.
 - PARTS ARE STACKABLE END TO END ON 2.54/.100 CENTERS.
 - CIRCUIT ONE DESIGNATION IS USED TO DEFINE VOID LOCATION. CIRCUIT ONE MAY OR MAY NOT LINE UP WITH CIRCUIT ONE ON THE MATING HOUSING.
 - PIN PUSHOUT FORCE: 2 LBS MIN.
 - THIS PART CONFORMS TO CLASS B REQUIREMENTS OF COSMETIC SPECIFICATION PS-45499-002.

ADD TAP AND REEL
 IEC NO: UCP2014-0335
 DRAWN: MKIPPER 2013/12/06
 CHKD: JBELL 2013/12/06
 APPR: F SMITH 2014/01/28
 REV: A2

QUALITY SYMBOLS
▽=0
▽=0
▽=0

	GENERAL TOLERANCES (UNLESS SPECIFIED)	
	mm	INCH
4 PLACES	± ---	± ---
3 PLACES	± ---	± .010
2 PLACES	± 0.25	± .015
1 PLACE	± 0.38	± ---
0 PLACE	±	±

ANGULAR ±1/2°
 DRAFT WHERE APPLICABLE
 MUST REMAIN WITHIN DIMENSIONS

DIMENSION STYLE	
MM/IN	
DRAWN BY	DATE
MKIPPER	2012/11/09
CHECKED BY	DATE
SSOUSEK	2012/12/04
APPROVED BY	DATE
F SMITH	2013/06/11

SCALE	DESIGN UNITS	THIRD ANGLE PROJECTION
4:1	INCH	☉
KK RPC .100 HEADER ASSEMBLY FRICTION LOCK SOLID BODY		
MATERIAL NO.	DOCUMENT NO.	SHEET NO.
SEE CHART	SD-171856-0001	1 OF *
THIS DRAWING CONTAINS INFORMATION THAT IS PROPRIETARY TO MOLEX INCORPORATED AND SHOULD NOT BE USED WITHOUT WRITTEN PERMISSION		

GROUP:	171856-0002/-0012			
PLATING:	197			
PIN LENGTH: (L)	12.95 / .510			
MATING: (M)	7.44 / .293			
DIM. G:	N/A			
PC TAIL: (P)	2.34 / .092			
DIM T:	OVERALL			
PACKAGING:	PK-6373-001 BULK			
CKTS	MATERIAL NUMBER	CKTS	MATERIAL NUMBER	VOID CKT
2	171856-0002			
3	171856-0003			
4	171856-0004			
5	171856-0005			
6	171856-0006			
7	171856-0007			
8	171856-0008			
9	171856-0009			
10	171856-0010			
11	171856-0011			
12	171856-0012			

GROUP:	171856-1002/-1012			
PLATING:	208			
PIN LENGTH: (L)	12.95 / .510			
MATING: (M)	7.44 / .293			
DIM. G:	3.56 / .140			
PC TAIL: (P)	2.34 / .092			
DIM T:	3.43 / .135			
PACKAGING:	PK-6373-001 BULK			
CKTS	MATERIAL NUMBER	CKTS	MATERIAL NUMBER	VOID CKT
2	171856-1002			
3	171856-1003			
4	171856-1004			
5	171856-1005			
6	171856-1006			
7	171856-1007			
8	171856-1008			
9	171856-1009			
10	171856-1010			
11	171856-1011			
12	171856-1012			

GROUP:	171856-2002/-2012			
PLATING:	228			
PIN LENGTH: (L)	12.95 / .510			
MATING: (M)	7.44 / .293			
DIM. G:	3.56 / .140			
PC TAIL: (P)	2.34 / .092			
DIM T:	3.43 / .135			
PACKAGING:	PK-6373-001 BULK			
CKTS	MATERIAL NUMBER	CKTS	MATERIAL NUMBER	VOID CKT
2	171856-2002			
3	171856-2003			
4	171856-2004			
5	171856-2005			
6	171856-2006			
7	171856-2007			
8	171856-2008			
9	171856-2009			
10	171856-2010			
11	171856-2011			
12	171856-2012			

REV: A2	ECR/ECN INFORMATION: EC No.: UCP2014-0335 DATE: 1/30/2014	TITLE: KK RPC 100 HEADER ASSEMBLY FRICTION LOCK SOLID BODY	SHEET No. - 2 -
DOCUMENT NUMBER: SD - 171856 - 0001		CREATED / REVISED BY: MKIPPER	CHECKED BY: JBELL
		APPROVED BY: FSMITH	

GROUP:	171856-0102/-0112			
PLATING:	197			
PIN LENGTH: (L)	14.22 / .560			
MATING: (M)	7.49 / .295			
DIM. G:	N/A			
PC TAIL: (P)	3.56 / .140			
DIM T:	OVERALL			
PACKAGING:	PK-6373-001 BULK			
CKTS	MATERIAL NUMBER	CKTS	MATERIAL NUMBER	VOID CKT
2	171856-0102			
3	171856-0103			
4	171856-0104			
5	171856-0105			
6	171856-0106			
7	171856-0107			
8	171856-0108			
9	171856-0109			
10	171856-0110			
11	171856-0111			
12	171856-0112			

GROUP:	171856-1102/-1112			
PLATING:	208			
PIN LENGTH: (L)	14.22 / .560			
MATING: (M)	7.49 / .295			
DIM. G:	3.56 / .140			
PC TAIL: (P)	3.56 / .140			
DIM T:	3.43 / .135			
PACKAGING:	PK-6373-001 BULK			
CKTS	MATERIAL NUMBER	CKTS	MATERIAL NUMBER	VOID CKT
2	171856-1102			
3	171856-1103			
4	171856-1104			
5	171856-1105			
6	171856-1106			
7	171856-1107			
8	171856-1108			
9	171856-1109			
10	171856-1110			
11	171856-1111			
12	171856-1112			

GROUP:				
PLATING:				
PIN LENGTH: (L)				
MATING: (M)				
DIM. G:				
PC TAIL: (P)				
DIM T:				
PACKAGING:				
CKTS	MATERIAL NUMBER	CKTS	MATERIAL NUMBER	VOID CKT

A2	REV:		<u>ECR/ECN INFORMATION:</u>		KK RPC 100 HEADER ASSEMBLY FRICTION LOCK SOLID BODY			<u>SHEET No.</u>	
			EC No.: UCP2014-0335					- 3 -	
			DATE: 1/30/2014						
<u>DOCUMENT NUMBER:</u> SD - 171856 - 0001			<u>CREATED / REVISED BY:</u> MKIPPER		<u>CHECKED BY:</u> JBELL		<u>APPROVED BY:</u> FSMITH		

GROUP:	171856-3002/-3012			
PLATING:	197			
PIN LENGTH: (L)	12.95 / .510			
MATING: (M)	7.44 / .293			
DIM. G:	N/A			
PC TAIL: (P)	2.34 / .092			
DIM T:	OVERALL			
PACKAGING:	PK-171856-0001 TAPE AND REEL W/CAP			
CKTS	MATERIAL NUMBER	CKTS	MATERIAL NUMBER	VOID CKT
2	171856-3002			
3	171856-3003			
4	171856-3004			
5	171856-3005			
6	171856-3006			
7	171856-3007			
8	171856-3008			
9	171856-3009			
10	171856-3010			
11	171856-3011			
12	171856-3012			

GROUP:	171856-4002/-4012			
PLATING:	208			
PIN LENGTH: (L)	12.95 / .510			
MATING: (M)	7.44 / .293			
DIM. G:	3.56 / .140			
PC TAIL: (P)	2.34 / .092			
DIM T:	3.43 / .135			
PACKAGING:	PK-171856-0001 TAPE AND REEL W/CAP			
CKTS	MATERIAL NUMBER	CKTS	MATERIAL NUMBER	VOID CKT
2	171856-4002			
3	171856-4003			
4	171856-4004			
5	171856-4005			
6	171856-4006			
7	171856-4007			
8	171856-4008			
9	171856-4009			
10	171856-4010			
11	171856-4011			
12	171856-4012			

GROUP:				
PLATING:				
PIN LENGTH: (L)				
MATING: (M)				
DIM. G:				
PC TAIL: (P)				
DIM T:				
PACKAGING:				
CKTS	MATERIAL NUMBER	CKTS	MATERIAL NUMBER	VOID CKT

REV: A2	<u>ECR/ECN INFORMATION:</u>		<u>TITLE:</u> KK RPC 100 HEADER ASSEMBLY FRICTION LOCK SOLID BODY	<u>SHEET No.</u>
	<u>EC No.:</u> UCP2014-0335	<u>DATE:</u> 1/30/2014		- 4 -
<u>DOCUMENT NUMBER:</u> SD - 171856 - 0001		<u>CREATED / REVISED BY:</u> MKIPPER	<u>CHECKED BY:</u> JBELL	<u>APPROVED BY:</u> FSMITH