

**MATERIALS AND FINISH:**

SHELL: STEEL MATERIAL, NICKEL FINISH  
 INSULATOR: PA6T = 260°C, UL 94V-0 RATED, BLACK  
 CONTACT MATERIAL: BRASS  
 CONTACT FINISH: FULL GOLD FLASH

**ELECTRICAL:**

CONTACT CURRENT RATING: 5 AMPS  
 CONTACT RESISTANCE: 30 Milliohms Max.  
 DIELECTRIC WITHSTANDING VOLTAGE: 1,000VAC Min.  
 INSULATION RESISTANCE: 5,000 Megohms Min.  
 TEMPERATURE RATING: -55° ~ +105° C

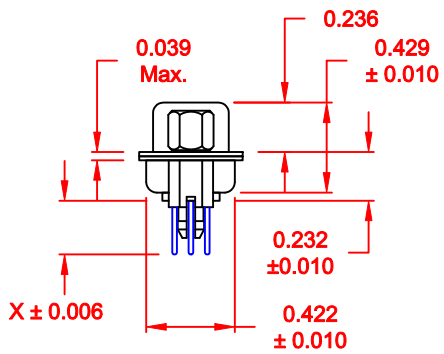
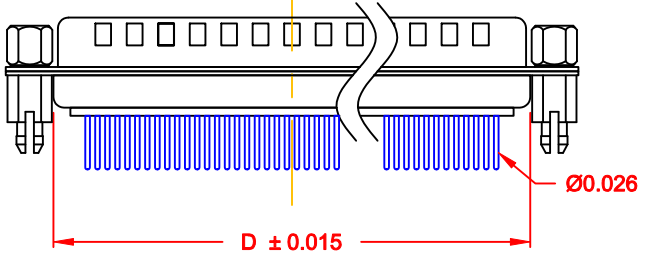
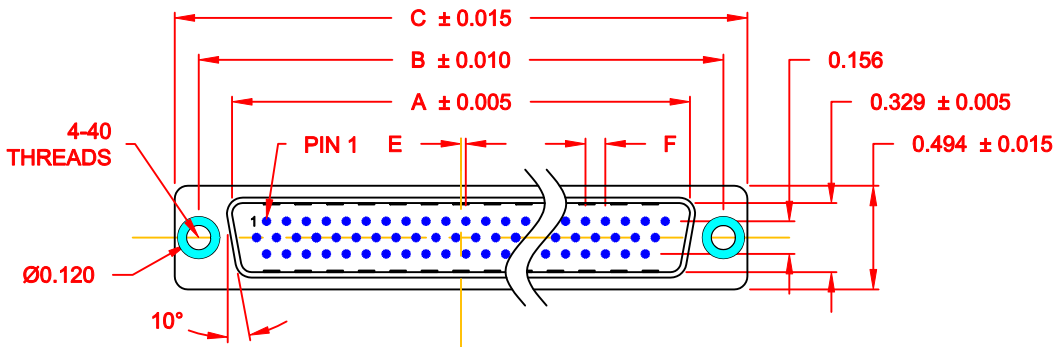

**180-MYY-1XYRYYY**

SERIES \_\_\_\_\_  
 MACHINED CONTACTS \_\_\_\_\_  
 POSITION \_\_\_\_\_  
 15 \_\_\_\_\_  
 26 \_\_\_\_\_  
 44 \_\_\_\_\_  
 62 \_\_\_\_\_  
 GENDER \_\_\_\_\_  
 1 = MALE \_\_\_\_\_  
 X = CONTACT LENGTH \_\_\_\_\_  
 1 = 0.256" \_\_\_\_\_  
 A = 0.140" \_\_\_\_\_  
 SHELL PLATING \_\_\_\_\_  
 3 = NICKEL \_\_\_\_\_  
 RoHS (HIGH TEMP.) 260° PROCESS \_\_\_\_\_  
 HARDWARE \_\_\_\_\_  
 00 = Ø 0.120" HOLE \_\_\_\_\_  
 01 = 0.098" 4-40 INSERT, BOARD SIDE \_\_\_\_\_  
 02 = 0.250" 4-40 INSERT, BOARD SIDE \_\_\_\_\_  
 03 = 0.250" 4-40 INSERT, MATING SIDE \_\_\_\_\_  
 05 = 0.224" 4-40 BOARD LOCK, BOARD SIDE \_\_\_\_\_  
 91 = 0.224" BOARD LOCK, BOARD SIDE \_\_\_\_\_  
 0.189" SCREW LOCK, MATING SIDE \_\_\_\_\_  
 CONTACT PLATING \_\_\_\_\_  
 1 = GOLD FLASH, ENTIRE CONTACT \_\_\_\_\_  
 2 = 30u" GOLD, ENTIRE CONTACT \_\_\_\_\_

**DIMENSIONS (IN.)**

No. OF PINS	A	B	C	D	E	F
15	0.666	0.984	1.213	0.759	0.010	0.090
26	0.994	1.312	1.541	1.083	0.020	0.090
44	1.534	1.852	2.088	1.625	0.020	0.090
62	2.182	2.500	2.729	2.256	0.023	0.094

DO NOT SCALE FROM DRAWING

	THESE DRAWINGS AND SPECIFICATIONS ARE THE PROPERTY OF NorComp AND SHALL NOT BE REPRODUCED, COPIED OR USED AS THE BASIS FOR THE MANUFACTURE OF SALE OF APPARATUS WITHOUT WRITTEN PERMISSION.		DRAWN: C. SMITH	DATE: 03-16-07
			CHECKED:	DATE:
<h1>NorComp</h1>	SCALE: 1 : 1	SHEET 1 OF 3	REV 6	
	DWG NO. 180-MYY-11YRYYY			

**RoHS COMPLIANT**

**TOLERANCE:**  
ALL DIMENSIONS ARE  $\pm 0.010$

**ALL CLINCH-NUTS ARE 4-40 INTERNAL THREADS**

05X ..... 0.224" BOARD SIDE - CN10

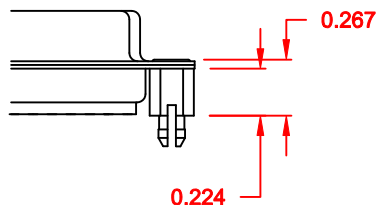

91X ..... 0.224" BOARD SIDE  
0.189 MATING SIDE  
CN10/SFSO4404

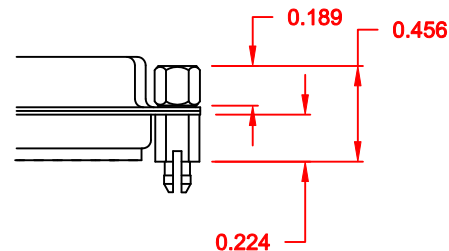

NOTE: 4-40 FEMALE SCREW LOCK IS REMOVABLE

01X ..... 0.098" (BOARD SIDE) - CN1

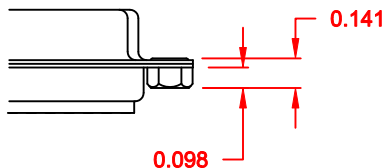

02X ..... 0.250" (BOARD SIDE) - CN2

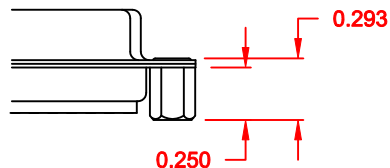

03X..... 0.250" (MATING SIDE) - CN8

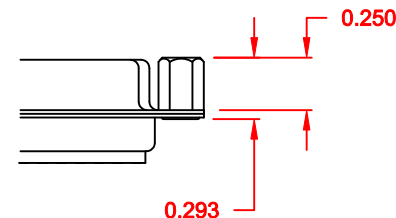

**DO NOT SCALE FROM DRAWING**

**RoHS COMPLIANT**

	THESE DRAWINGS AND SPECIFICATIONS ARE THE PROPERTY OF NorComp AND SHALL NOT BE REPRODUCED, COPIED OR USED AS THE BASIS FOR THE MANUFACTURE OF SALE OF APPARATUS WITHOUT WRITTEN PERMISSION.		DRAWN: <b>C. SMITH</b>	DATE: <b>02-12-08</b>
			CHECKED:	DATE:
<h1>NorComp</h1>		SCALE:	SHEET <b>2</b> OF <b>3</b>	REV <b>6</b>
		DWG NO. <b>180-MYY-11YRYYY</b>		

DESCRIPTION: LAYOUT - HIGH DENSITY - MACHINED CONTACTS - VERTICAL

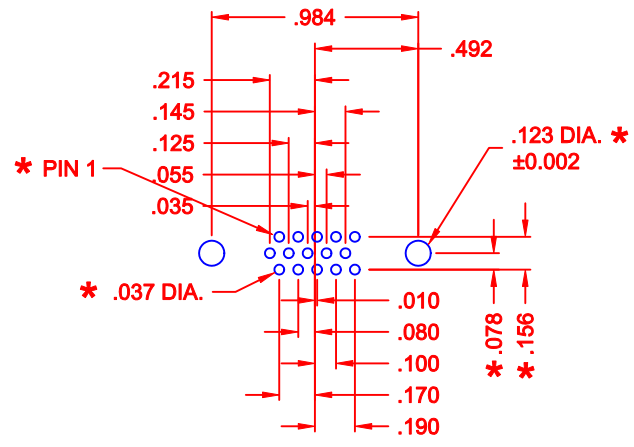

15 POSITION

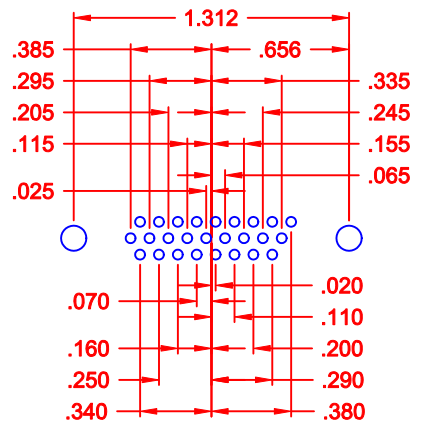

26 POSITION

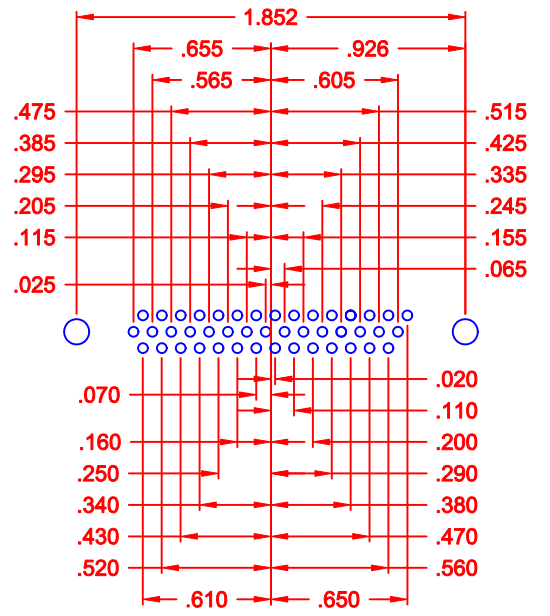

44 POSITION

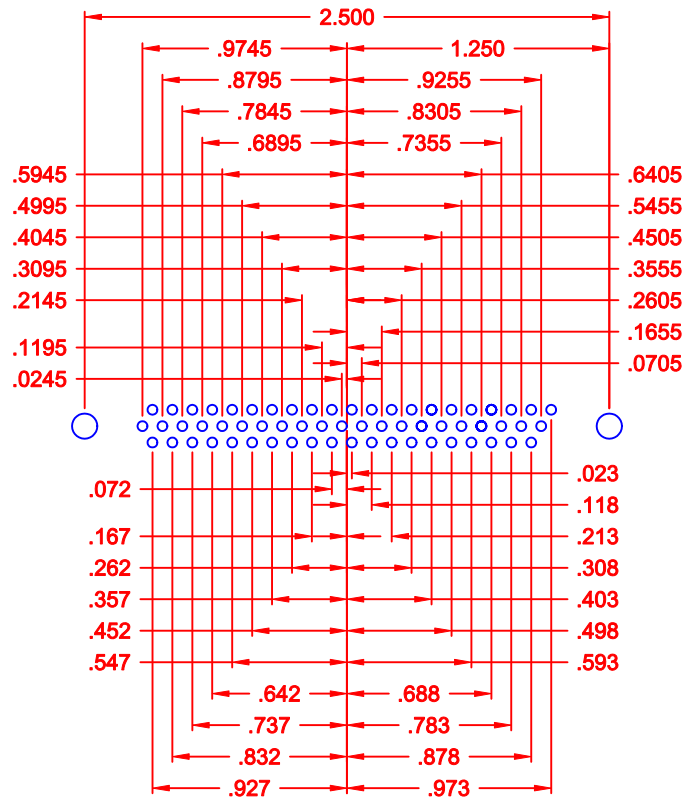

62 POSITION

\* TYP. ON ALL SIZES

DO NOT SCALE FROM DRAWING

	THESE DRAWINGS AND SPECIFICATIONS ARE THE PROPERTY OF NorComp AND SHALL NOT BE REPRODUCED, COPIED OR USED AS THE BASIS FOR THE MANUFACTURE OF SALE OF APPARATUS WITHOUT WRITTEN PERMISSION.		DRAWN: <b>C. SMITH</b>	DATE: <b>03-16-07</b>
			CHECKED:	DATE:
<b>NorComp</b>		SCALE: 1 : 1	SHEET 3 OF 3	REV 6
		DWG NO. <b>180-MYY-11YRYYY</b>		