

THIS DRAWING IS UNPUBLISHED. RELEASED FOR PUBLICATION
 © COPYRIGHT BY TYCO ELECTRONICS CORPORATION. ALL RIGHTS RESERVED.

LOC	DIST	REVISIONS			
P	LTR	DESCRIPTION	DATE	DWN	APVD
AF	50	T	REV PER 0G3A-0770-03	06JUL04	JR RL

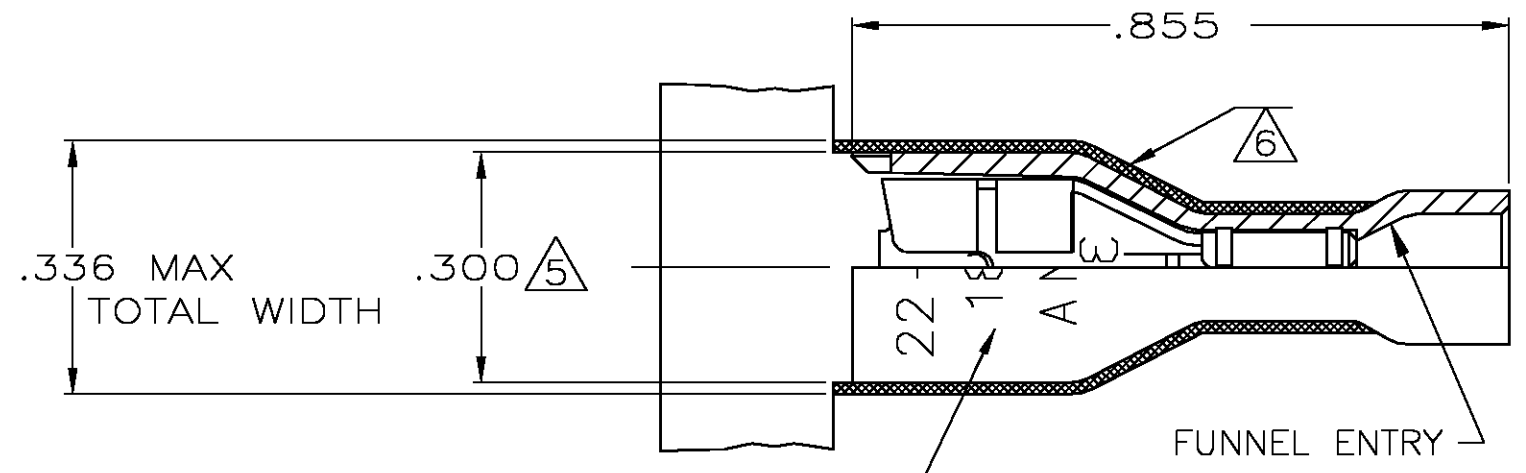

- 1 MATES WITH .032±.001x.187 TAB
- 2 WIRE STRIP LENGTH .281
- 3 INSULATION SIZE .135 MAX DIA
- 4 CONTINUOUS STRIP ON REELS
- 5 DIMENSION DOES NOT INCLUDE TRIM BURR
- 6 .015 MAX CARRIER TRIM BURR PER SIDE IS ALLOWABLE IN THE SHADED AREA

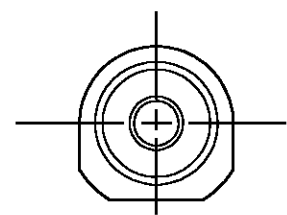
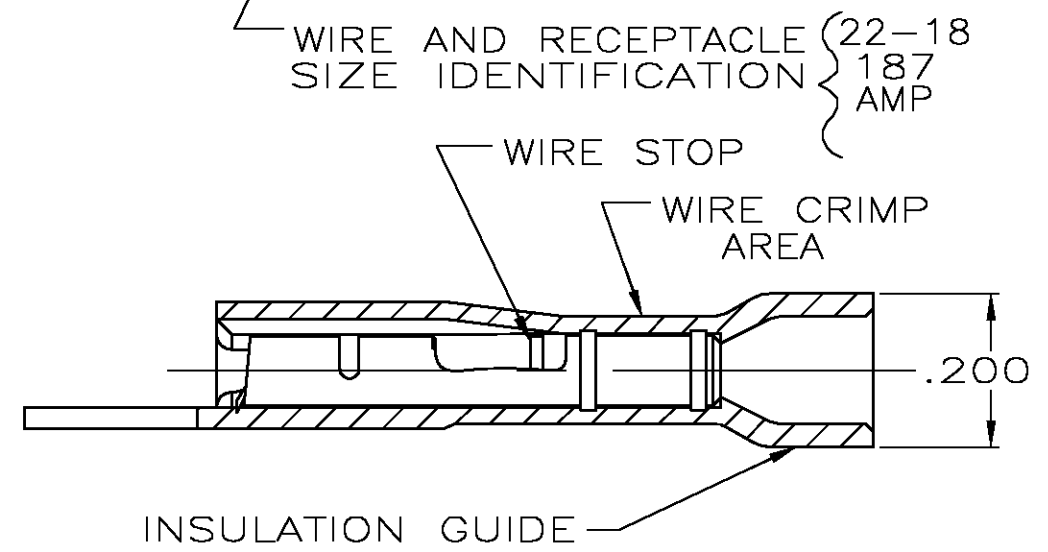
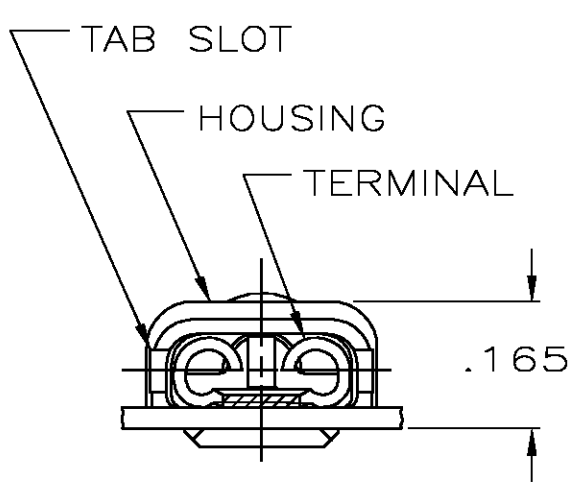

HOUSING: NYLON, COLOR-BLACK RECEPTACLE: #3 HARD BRASS TIN PL .000080 MIN THK	9-520193-2
HOUSING: NYLON, COLOR-RED TRANSLUCENT RECEPTACLE: #3 HARD BRASS TIN PL .000080 MIN THK	2-520193-2
MATERIAL & FINISH	PART NO.

THIS DRAWING IS A CONTROLLED DOCUMENT.		DWN P FORTNEY 10/13/88	Tyco Electronics Corporation Harrisburg, Pa 17105-3608	
DIMENSIONS: INCHES		CHK JR RUTH 10/13/88		
TOLERANCES UNLESS OTHERWISE SPECIFIED:		APVD D BRATINA 10/13/88	NAME RECEPTACLE ASSY, ULTRA-FAST, .187 SERIES, 22-18 AWG	
0 PLC ± - 1 PLC ± - 2 PLC ± - 3 PLC ± .015 4 PLC ± - ANGLES ± -		PRODUCT SPEC 108-2043	RESTRICTED TO	
MATERIAL SEE TABLE		APPLICATION SPEC 114-2123	SIZE A3	CAGE CODE 00779
FINISH SEE TABLE		WEIGHT -	DRAWING NO C-520193	REV T
CUSTOMER DRAWING			SCALE 4:1	SHEET 1 OF 1