

## FEATURES

- Fixed Frequency 1.2MHz/2.2MHz Operation
- Very Low Noise: 1mV<sub>P-P</sub> Output Ripple
- -5V at 350mA from 5V Input
- -12V at 150mA from 5V Input
- Uses Small Surface Mount Components
- Wide Input Range: 2.6V to 16V
- Low Shutdown Current: <1μA
- Low V<sub>CESAT</sub> Switch: 400mV at 1A
- Pin-for-Pin Compatible with the LT1611
- Low Profile (1mm) ThinSOT™ Package

## APPLICATIONS

- Disk Drive MR Head Bias
- Digital Camera CCD Bias
- LCD Bias
- GaAs FET Bias
- Local Low Noise/Low Impedance Negative Supply

## DESCRIPTION

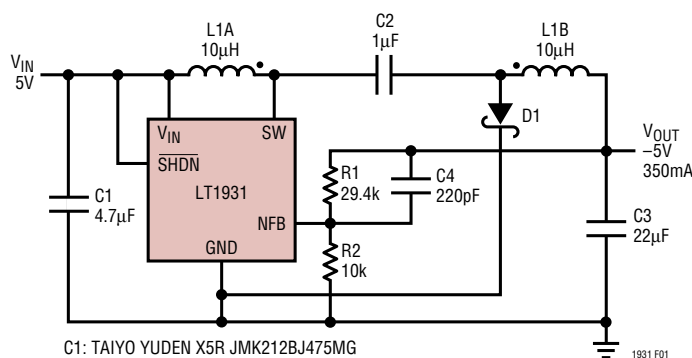
The LT<sup>®</sup>1931/LT1931A are the industry's highest power inverting SOT-23 current mode DC/DC converters. Both parts include a 1A integrated switch allowing high current outputs to be generated in a small footprint. The LT1931 switches at 1.2MHz while the LT1931A switches at 2.2MHz. These high speeds enable the use of tiny, low cost capacitors and inductors 2mm or less in height. The LT1931 is capable of generating -5V at 350mA or -12V at 150mA from a 5V supply, while the LT1931A can generate -5V at 300mA using significantly smaller inductors. Both parts are easy pin-for-pin upgrades for higher power LT1611 applications.

The LT1931/LT1931A operate in a dual inductor inverting topology that filters both the input side and output side current. Very low output voltage ripple approaching 1mV<sub>P-P</sub> can be achieved when ceramic output capacitors are used. Fixed frequency switching ensures a clean output free from low frequency noise typically present with charge pump solutions. The low impedance output remains within 1% of nominal during large load steps. The 36V switch allows V<sub>IN</sub> to V<sub>OUT</sub> differential of up to 34V.

The LT1931/LT1931A are available in the 5-lead ThinSOT package.

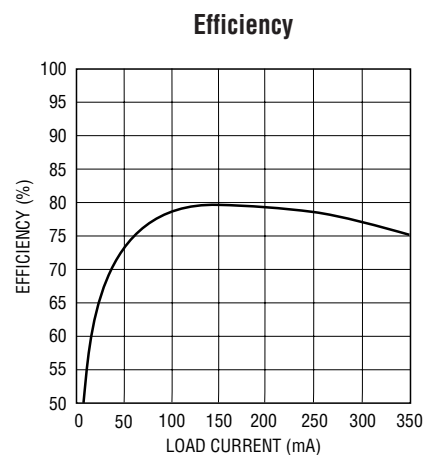
LT, LTC and LT are registered trademarks of Linear Technology Corporation. ThinSOT is a trademark of Linear Technology Corporation. All other trademarks are the property of their respective owners.

## TYPICAL APPLICATION



C1: TAIYO YUDEN X5R JMK212BJ475MG  
 C2: TAIYO YUDEN X5R LMK212BJ105MG  
 C3: TAIYO YUDEN X5R JMK325BJ226MM  
 D1: ON SEMICONDUCTOR MBR0520  
 L1: SUMIDA CLS62-100

Figure 1. 5V to -5V, 350mA Inverting DC/DC Converter



1931 TA01

1931fa

## ABSOLUTE MAXIMUM RATINGS

(Note 1)

$V_{IN}$ Voltage .....	16V
SW Voltage .....	-0.4V to 36V
NFB Voltage .....	-2V
Current Into NFB Pin .....	$\pm 1$ mA
SHDN Voltage .....	16V
Maximum Junction Temperature .....	125°C
Operating Temperature Range (Note 2) ..	-40°C to 85°C
Storage Temperature Range .....	-65°C to 150°C
Lead Temperature (Soldering, 10 sec) .....	300°C

## PACKAGE/ORDER INFORMATION

<p>S5 PACKAGE 5-LEAD PLASTIC TSOT-23 <math>T_{JMAX} = 125^{\circ}\text{C}</math>, <math>\theta_{JA} = 150^{\circ}\text{C/W}</math></p>	
ORDER PART NUMBER	S5 PART MARKING
LT1931ES5 LT1931AES5 LT1931IS5 LT1931AIS5	LTRA LTSP LTBZF LTBZG
<b>Order Options</b> Tape and Reel: Add #TR Lead Free: Add #PBF Lead Free Tape and Reel: Add #TRPBF Lead Free Part Marking: <a href="http://www.linear.com/leadfree/">http://www.linear.com/leadfree/</a>	

Consult LTC Marketing for parts specified with wider operating temperature ranges.

## ELECTRICAL CHARACTERISTICS

The ● denotes specifications which apply over the full operating temperature range, otherwise specifications are  $T_A = 25^{\circ}\text{C}$ .  
 $V_{IN} = 3\text{V}$ ,  $V_{SHDN} = V_{IN}$ , unless otherwise noted. (Note 2)

PARAMETER	CONDITIONS	LT1931			LT1931A			UNITS
		MIN	TYP	MAX	MIN	TYP	MAX	
Minimum Operating Voltage		2.45	2.6		2.45	2.6		V
Maximum Operating Voltage				16			16	V
Feedback Voltage		-1.275	-1.255	-1.235	-1.275	-1.255	-1.235	V
		● -1.280		-1.230	-1.280		-1.230	V
NFB Pin Bias Current	$V_{NFB} = -1.255\text{V}$		● 4	8		8	16	$\mu\text{A}$
Quiescent Current	$V_{SHDN} = 2.4\text{V}$ , Not Switching		4.2	6		5.8	8	mA
Quiescent Current in Shutdown	$V_{SHDN} = 0\text{V}$ , $V_{IN} = 3\text{V}$		0.01	1		0.01	1	$\mu\text{A}$
Reference Line Regulation	$2.6\text{V} \leq V_{IN} \leq 16\text{V}$		0.01	0.05		0.01	0.05	%/V
Switching Frequency		● 1	1.2	1.4	1.8	2.2	2.6	MHz
		0.85		1.6	1.6		2.9	MHz
Maximum Duty Cycle		● 84	90		75	82		%
Switch Current Limit	(Note 3)	1	1.2	2	1	1.2	2.5	A
Switch $V_{CESAT}$	$I_{SW} = 1\text{A}$		400	600		400	600	mV
Switch Leakage Current	$V_{SW} = 5\text{V}$		0.01	1		0.01	1	$\mu\text{A}$
SHDN Input Voltage, High			2.4		2.4			V
SHDN Input Voltage, Low				0.5		0.5		V
SHDN Pin Bias Current	$V_{SHDN} = 3\text{V}$		16	32		35	70	$\mu\text{A}$
	$V_{SHDN} = 0\text{V}$		0	0.1		0	0.1	$\mu\text{A}$

**Note 1:** Absolute Maximum Ratings are those values beyond which the life of a device may be impaired.

**Note 2:** The LT1931E/LT1931AE are guaranteed to meet performance specifications from 0°C to 70°C. Specifications over the -40°C to 85°C

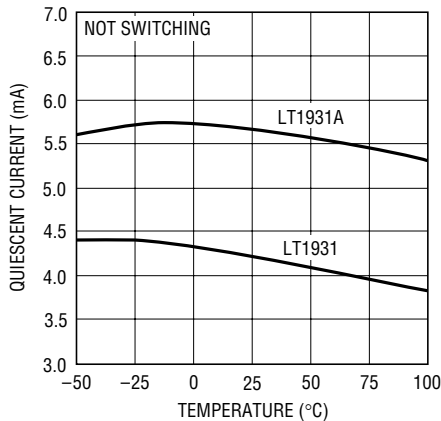
operating temperature range are assured by design, characterization and correlation with statistical process controls. LT1931/LT1931A are guaranteed over the -40°C to 85°C temperature range.

**Note 3:** Current limit guaranteed by design and/or correlation to static test.

1931fa

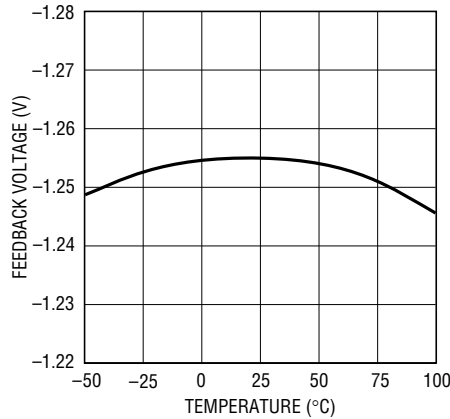
## TYPICAL PERFORMANCE CHARACTERISTICS

Quiescent Current



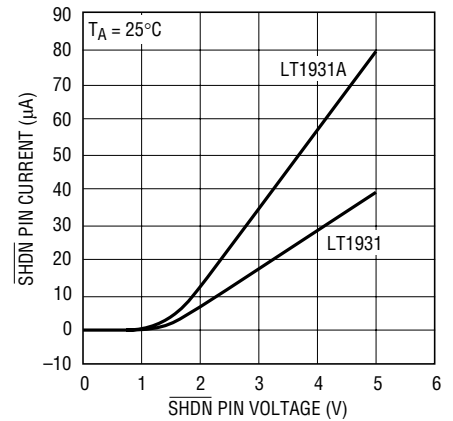
1931 G01

Feedback Pin Voltage



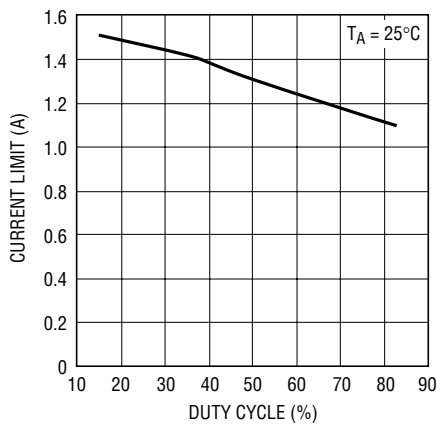
1931 G02

Shutdown Pin Current



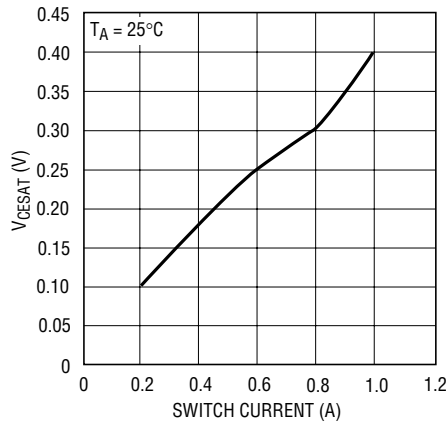
1931 G03

Current Limit



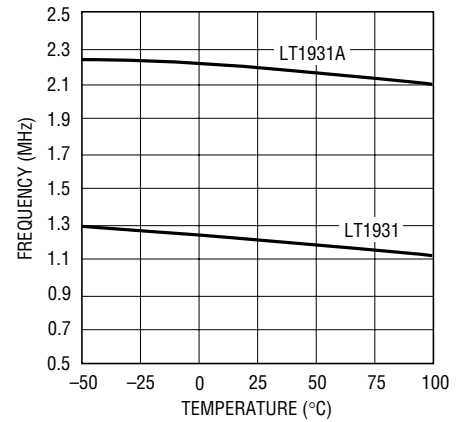
1931 G04

Switch Saturation Voltage



1931 G05

Oscillator Frequency



1931 G06

## PIN FUNCTIONS

**SW (Pin 1):** Switch Pin. Connect inductor/diode here. Minimize trace area at this pin to keep EMI down.

**GND (Pin 2):** Ground. Tie directly to local ground plane.

**NFB (Pin 3):** Feedback Pin. Reference voltage is  $-1.255\text{V}$ . Connect resistive divider tap here. Minimize trace area. The NFB bias current flows out of the pin. Set R1 and R2 according to:

$$\text{For LT1931: } R1 = \frac{|V_{\text{OUT}}| - 1.255}{\frac{1.255}{R2} + (4 \cdot 10^{-6})}$$

$$\text{For LT1931A: } R1 = \frac{|V_{\text{OUT}}| - 1.255}{\frac{1.255}{R2} + (8 \cdot 10^{-6})}$$

**SHDN (Pin 4):** Shutdown Pin. Tie to  $2.4\text{V}$  or more to enable device. Ground to shut down.

**V<sub>IN</sub> (Pin 5):** Input Supply Pin. Must be locally bypassed.

**BLOCK DIAGRAM**

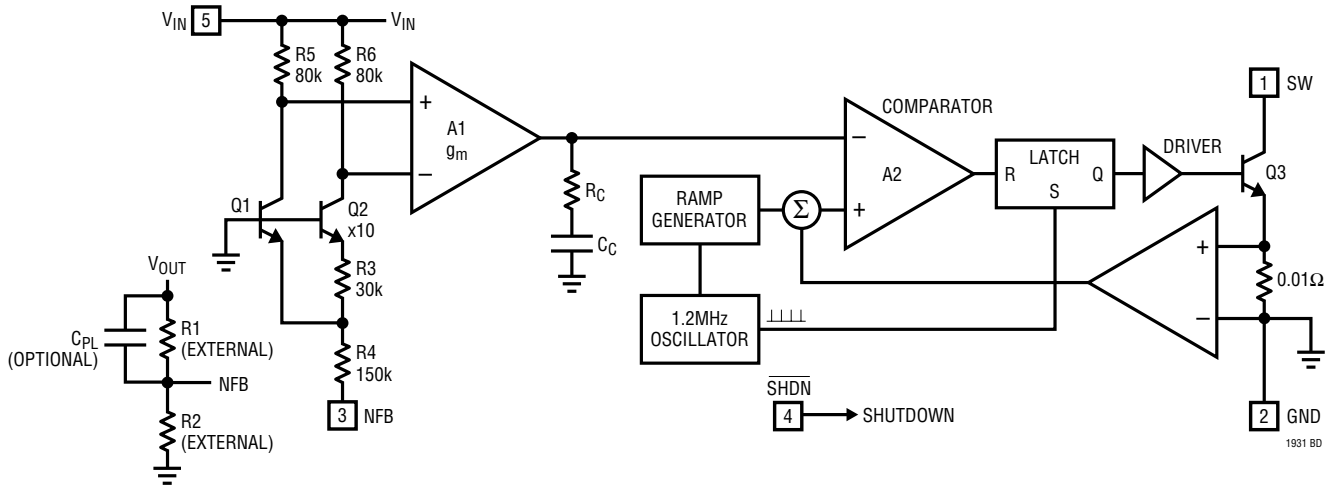


Figure 2

**OPERATION**

The LT1931 uses a constant frequency, current mode control scheme to provide excellent line and load regulation. Operation can be best understood by referring to the Block Diagram in Figure 2. At the start of each oscillator cycle, the SR latch is set, turning on the power switch Q3. A voltage proportional to the switch current is added to a stabilizing ramp and the resulting sum is fed into the positive terminal of the PWM comparator A2. When this voltage exceeds the level at the negative input of A2, the SR latch is reset, turning off the power switch. The level at the negative input of A2 is set by the error amplifier ( $g_m$ ) and is simply an amplified version of the difference between the feedback voltage and the reference voltage of  $-1.255V$ . In this manner, the error amplifier sets the correct peak

current level to keep the output in regulation. If the error amplifier's output increases, more current is taken from the output; if it decreases, less current is taken. One function not shown in Figure 2 is the current limit. The switch current is constantly monitored and not allowed to exceed the nominal value of 1.2A. If the switch current reaches 1.2A, the SR latch is reset regardless of the state of comparator A2. This current limit protects the power switch as well as various external components connected to the LT1931.

The Block Diagram for the LT1931A is identical except that the oscillator is 2.2MHz and resistors R3 to R6 are one-half the LT1931 values.

## APPLICATIONS INFORMATION

### LT1931A AND LT1931 DIFFERENCES:

#### Switching Frequency

The key difference between the LT1931A and LT1931 is the faster switching frequency of the LT1931A. At 2.2MHz, the LT1931A switches at nearly twice the rate of the LT1931. Care must be taken in deciding which part to use. The high switching frequency of the LT1931A allows smaller cheaper inductors and capacitors to be used in a given application, but with a slight decrease in efficiency and maximum output current when compared to the LT1931. Generally, if efficiency and maximum output current are critical, the LT1931 should be used. If application size and cost are more important, the LT1931A will be the better choice. In many applications, tiny inexpensive chip inductors can be used with the LT1931A, reducing solution cost.

#### Duty Cycle

The maximum duty cycle (DC) of the LT1931A is 75% compared to 84% for the LT1931. The duty cycle for a given application using the dual inductor inverting topology is given by:

$$DC = \frac{|V_{OUT}|}{|V_{IN}| + |V_{OUT}|}$$

For a 5V to -5V application, the DC is 50% indicating that the LT1931A can be used. A 5V to -16V application has a DC of 76.2% making the LT1931 the right choice. The LT1931A can still be used in applications where the DC, as calculated above, is above 75%. However, the part must be operated in the discontinuous conduction mode so that the actual duty cycle is reduced.

#### INDUCTOR SELECTION

Several inductors that work well with the LT1931 are listed in Table 1 and those for the LT1931A are listed in Table 2. Besides these, there are many other inductors that can be used. Consult each manufacturer for detailed information and for their entire selection of related parts. Ferrite core inductors should be used to obtain the best efficiency, as

core losses at frequencies above 1MHz are much lower for ferrite cores than for powdered-iron units. When using coupled inductors, choose one that can handle at least 1A of current without saturating, and ensure that the inductor has a low DCR (copper-wire resistance) to minimize  $I^2R$  power losses. If using uncoupled inductors, each inductor need only handle one-half of the total switch current so that 0.5A per inductor is sufficient. A 4.7μH to 15μH coupled inductor or a 15μH to 22μH uncoupled inductor will usually be the best choice for most LT1931 designs. For the LT1931A, a 2.2μH to 4.7μH coupled inductor or a 3.3μH to 10μH uncoupled inductor will usually suffice. In certain applications such as the “Charge Pump” inverting DC/DC converter, only a single inductor is used. In this case, the inductor must carry the entire 1A switch current.

**Table 1. Recommended Inductors—LT1931**

PART	L (μH)	Size (L × W × H) mm	VENDOR
CLS62-100	10	6.8 × 6.6 × 2.5	Sumida
CR43-150	15	4.5 × 4.0 × 3.2	(847) 956-0666
CR43-220	22		www.sumida.com
CTX10-1	10	8.9 × 11.4 × 4.2	Coiltronics
CTX15-1	15		(407) 241-7876
			www.coiltronics.com
LQH3C100K24	10	3.2 × 2.5 × 2.0	Murata
LQH4C150K04	15		(404) 436-1300
			www.murata.com

**Table 2. Recommended Inductors—LT1931A**

PART	L (μH)	Size (L × W × H) mm	VENDOR
ELJPC3R3MF	3.3	2.5 × 2.0 × 1.6	Panasonic
ELJPC4R7MF	4.7		(408) 945-5660
			www.panasonic.com
CLQ4D10-4R7 <sup>1</sup>	4.7	7.6 × 4.8 × 1.8	Sumida
CLQ4D10-6R8 <sup>2</sup>	6.8		(847) 956-0666
			www.sumida.com
LB20164R7M	4.7	2.0 × 1.6 × 1.6	Taiyo Yuden
LB20163R3M	3.3		(408) 573-4150
			www.t-yuden.com
LQH3C4R7K24	4.7	3.2 × 2.5 × 2.0	Murata
LQH4C100K24	10		(404) 436-1300
			www.murata.com

<sup>1</sup>Use drawing #5382-T039

<sup>2</sup>Use drawing #5382-T041

## APPLICATIONS INFORMATION

The inductors shown in Table 2 for use with the LT1931A were chosen for their small size. For better efficiency, use similar valued inductors with a larger volume. For instance, the Sumida CR43 series, in values ranging from 3.3μH to 10μH, will give a LT1931A application a few percentage points increase in efficiency.

### CAPACITOR SELECTION

Low ESR (equivalent series resistance) capacitors should be used at the output to minimize the output ripple voltage. Multilayer ceramic capacitors are an excellent choice, as they have an extremely low ESR and are available in very small packages. X5R dielectrics are preferred, followed by X7R, as these materials retain their capacitance over wide voltage and temperature ranges. A 10μF to 22μF output capacitor is sufficient for most LT1931 applications while a 4.7μF to 10μF capacitor will suffice for the LT1931A. Solid tantalum or OS-CON capacitors can be used, but they will occupy more board area than a ceramic and will have a higher ESR. Always use a capacitor with a sufficient voltage rating.

Ceramic capacitors also make a good choice for the input decoupling capacitor, which should be placed as close as possible to the LT1931/LT1931A. A 1μF to 4.7μF input capacitor is sufficient for most applications. Table 3 shows a list of several ceramic capacitor manufacturers. Consult the manufacturers for detailed information on their entire selection of ceramic parts.

**Table 3. Ceramic Capacitor Manufacturers**

Taiyo Yuden	(408) 573-4150 www.t-yuden.com
AVX	(803) 448-9411 www.avxcorp.com
Murata	(714) 852-2001 www.murata.com

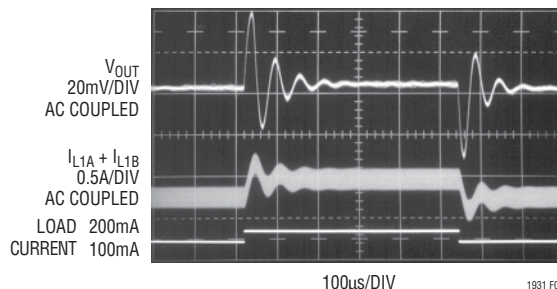
The decision to use either low ESR (ceramic) capacitors or the higher ESR (tantalum or OS-CON) capacitors can effect the stability of the overall system. The ESR of any capacitor, along with the capacitance itself, contributes a

zero to the system. For the tantalum and OS-CON capacitors, this zero is located at a lower frequency due to the higher value of the ESR, while the zero of a ceramic capacitor is at a much higher frequency and can generally be ignored.

A phase lead zero can be intentionally introduced by placing a capacitor (C4) in parallel with the resistor (R1) between V<sub>OUT</sub> and V<sub>NFB</sub> as shown in Figure 1. The frequency of the zero is determined by the following equation.

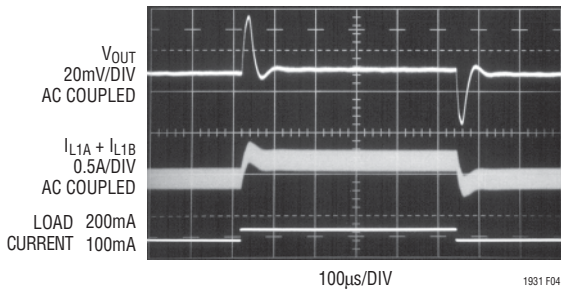
$$f_z = \frac{1}{2\pi \cdot R1 \cdot C4}$$

By choosing the appropriate values for the resistor and capacitor, the zero frequency can be designed to improve the phase margin of the overall converter. The typical target value for the zero frequency is between 20kHz to 60kHz. Figure 3 shows the transient response of the inverting converter from Figure 1 without the phase lead capacitor C4. The phase margin is reduced as evidenced by more ringing in both the output voltage and inductor current. A 220pF capacitor for C4 results in better phase margin, which is revealed in Figure 4 as a more damped response and less overshoot. Figure 5 shows the transient response when a 22μF tantalum capacitor with no phase lead capacitor is used on the output. The higher output voltage ripple is revealed in the upper waveform as a thicker line. The transient response is adequate which implies that the ESR zero is improving the phase margin.

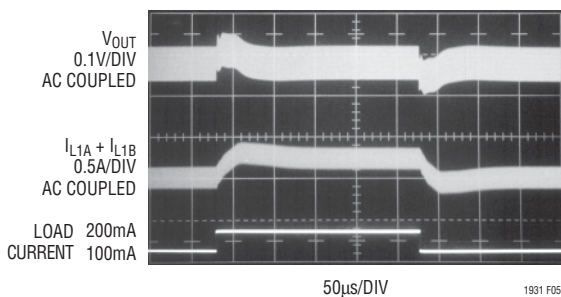


**Figure 3. Transient Response of Inverting Converter Without Phase Lead Capacitor**

## APPLICATIONS INFORMATION



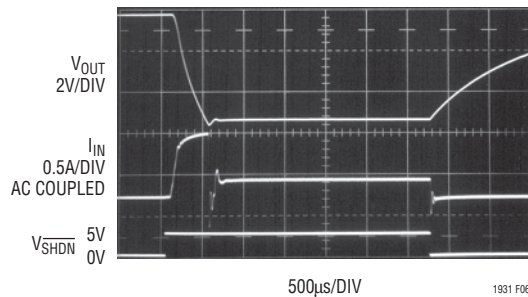
**Figure 4. Transient Response of Inverting Converter with 220pF Phase Lead Capacitor**



**Figure 5. Transient Response of Inverting Converter with 22µF Tantalum Output Capacitor and No Phase Lead Capacitor**

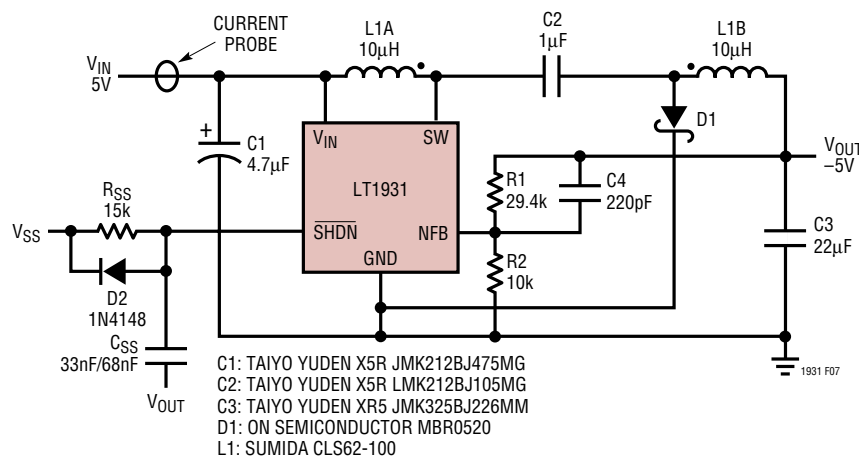
### START-UP/SOFT-START

For most LT1931/LT1931A applications, the start-up inrush current can be high. This is an inherent feature of switching regulators in general since the feedback loop is saturated due to  $V_{OUT}$  being far from its final value. The



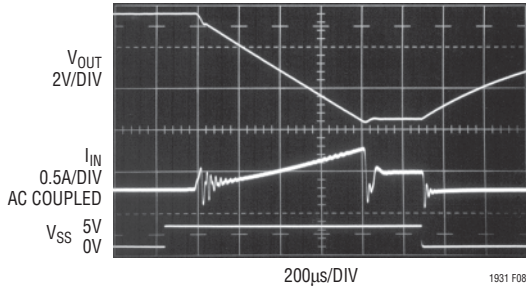
**Figure 6. Start-Up Waveforms for 5V to -5V Application (Figure 1). No Soft-Start Circuit.  $V_{OUT}$  Reaches -5V in 500µs; Input Current Peaks at 800mA**

regulator tries to charge up the output capacitor as quickly as possible, which results in a large inrush current. Figure 6 shows a typical oscillograph of the start-up waveform for the application of Figure 1 starting into a load of 33Ω. The lower waveform shows  $\overline{SHDN}$  being pulsed from 0V to 5V. The middle waveform shows the input current, which reaches as high as 0.8A. The total time required for the output to reach its final value is approximately 500µs. For some applications, this initial inrush current may not be acceptable. If a longer start-up time is acceptable, a soft-start circuit consisting of  $R_{SS}$  and  $C_{SS}$ , as shown in Figure 7, can be used to limit inrush current to a lower value. Figure 8 shows the relevant waveforms with  $R_{SS} = 15k$  and  $C_{SS} = 33nF$ . Input current, measured at  $V_{IN}$ , is limited to a peak value of 0.5A as the time required to reach final value increases to 1ms. In Figure 9,  $C_{SS}$  is

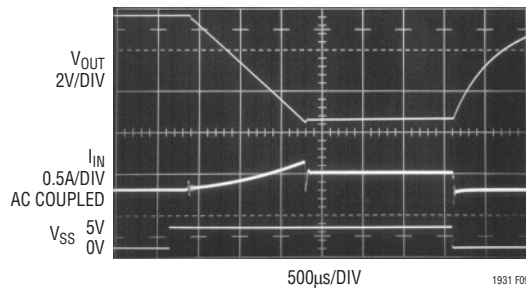


**Figure 7.  $R_{SS}$  and  $C_{SS}$  at  $\overline{SHDN}$  Pin Provide Soft-Start to LT1931 Inverting Converter**

## APPLICATIONS INFORMATION



**Figure 8.**  $R_{SS} = 15k$ ,  $C_{SS} = 33nF$ ;  $V_{OUT}$  Reaches  $-5V$  in  $1ms$ ; Input Current Peaks at  $500mA$



**Figure 9.**  $R_{SS} = 15k$ ,  $C_{SS} = 68nF$ ;  $V_{OUT}$  Reaches  $-5V$  in  $1.6ms$ ; Input Current Peaks at  $350mA$

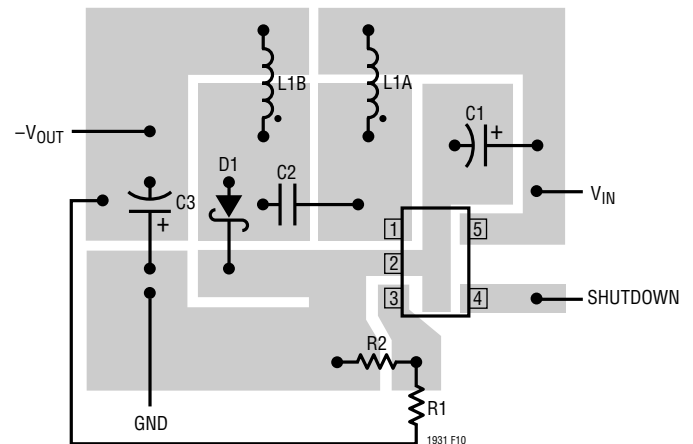
increased to  $68nF$ , resulting in a lower peak input current of  $350mA$  with a  $V_{OUT}$  ramp time of  $1.6ms$ .  $C_{SS}$  or  $R_{SS}$  can be increased further for an even slower ramp, if desired. Diode  $D2$  serves to quickly discharge  $C_{SS}$  when  $V_{SS}$  is driven low to shut down the device.  $D2$  can be omitted, resulting in a “soft-stop” slow discharge of the output capacitor.

### DIODE SELECTION

A Schottky diode is recommended for use with the LT1931/LT1931A. The Motorola MBR0520 is a very good choice. Where the input to output voltage differential exceeds  $20V$ , use the MBR0530 (a  $30V$  diode). These diodes are rated to handle an average forward current of  $0.5A$ . In applications where the average forward current of the diode exceeds  $0.5A$ , a Microsemi UPS5817 rated at  $1A$  is recommended.

### LAYOUT HINTS

The high-speed operation of the LT1931/LT1931A demands careful attention to board layout. You will not get advertised performance with careless layout. Figure 10 shows the recommended component placement. The ground cut at the cathode of  $D1$  is essential for low noise operation.

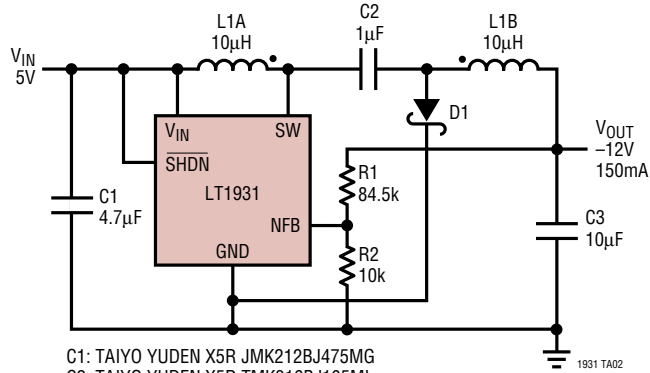


**Figure 10.** Suggested Component Placement. Note Cut in Ground Copper at  $D1$ 's Cathode



# TYPICAL APPLICATIONS

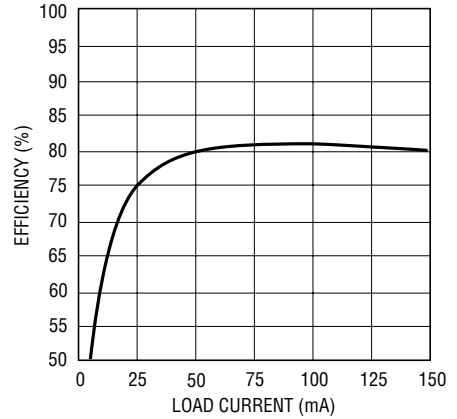
5V to -12V Inverting Converter



- C1: TAIYO YUDEN X5R JMK212BJ475MG
- C2: TAIYO YUDEN X5R TMK316BJ105ML
- C3: TAIYO YUDEN X5R EMK325BJ106MM
- D1: ON SEMICONDUCTOR MBR0520
- L1: SUMIDA CLS62-100

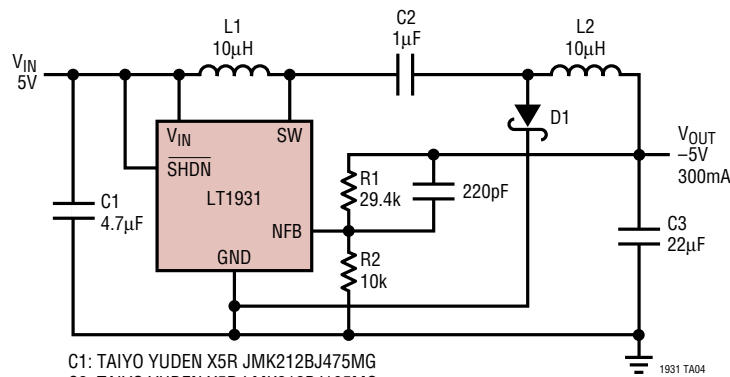
1931 TA02

Efficiency



1931 TA03

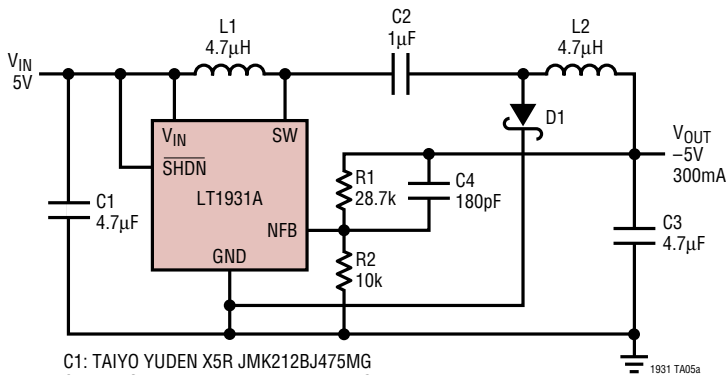
5V to -5V Inverting Converter Using Uncoupled Inductors



- C1: TAIYO YUDEN X5R JMK212BJ475MG
- C2: TAIYO YUDEN X5R LMK212BJ105MG
- C3: TAIYO YUDEN X5R JMK212BJ226MM
- D1: ON SEMICONDUCTOR MBR0520
- L1, L2: MURATA LQH3C100K04

1931 TA04

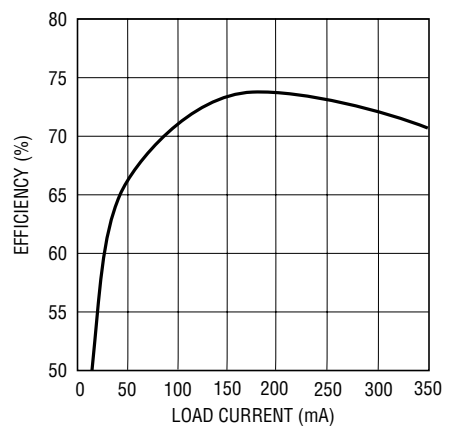
2.2MHz, 5V to -5V Inverting Converter



- C1: TAIYO YUDEN X5R JMK212BJ475MG
- C2: TAIYO YUDEN X5R LMK212BJ105MG
- C3: TAIYO YUDEN X5R JMK212BJ475MG
- D1: ON SEMICONDUCTOR MBR0520
- L1, L2: MURATA LQH3C4R7M24

1931 TA05a

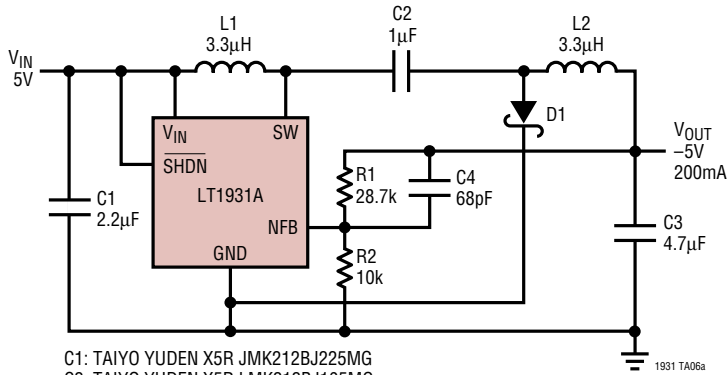
Efficiency



1931 TA05b

## TYPICAL APPLICATIONS

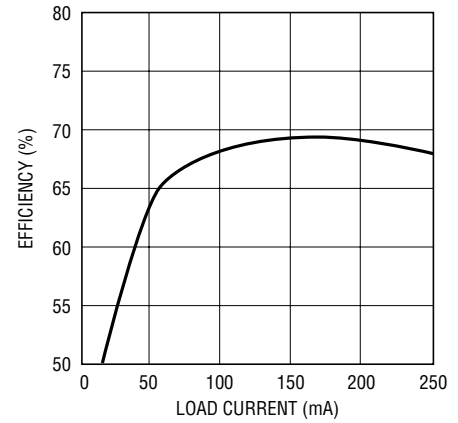
### 2.2MHz, 5V to -5V Converter Uses Tiny Chip Inductors



C1: TAIYO YUDEN X5R JMK212BJ225MG  
 C2: TAIYO YUDEN X5R LMK212BJ105MG  
 C3: TAIYO YUDEN X5R JMK212BJ475MG  
 D1: ON SEMICONDUCTOR MBR0520  
 L1, L2: PANASONIC ELJPC3R3MF

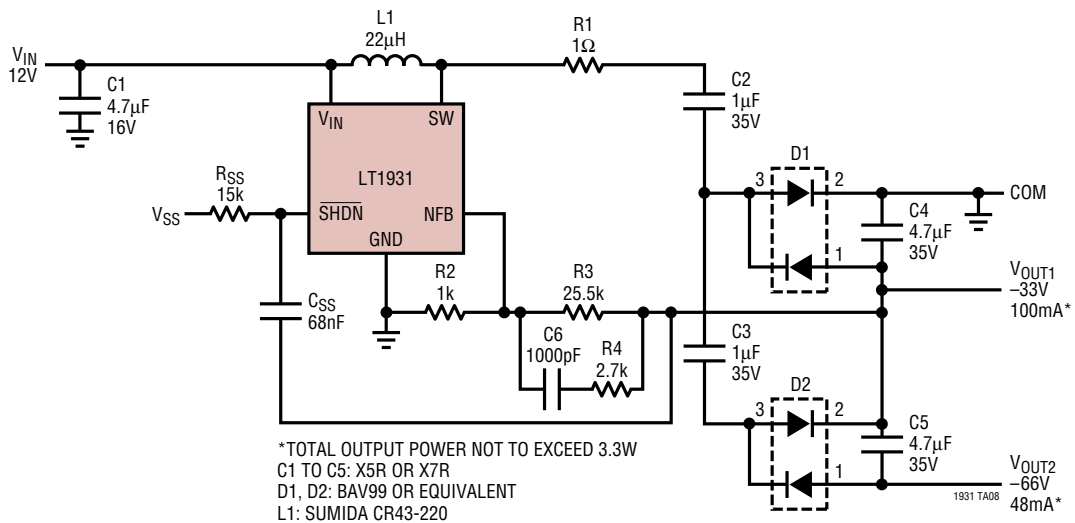
1931 TA06a

### Efficiency



1931 TA06b

### SLIC Power Supply with -33V and -68V Outputs, Uses Soft-Start

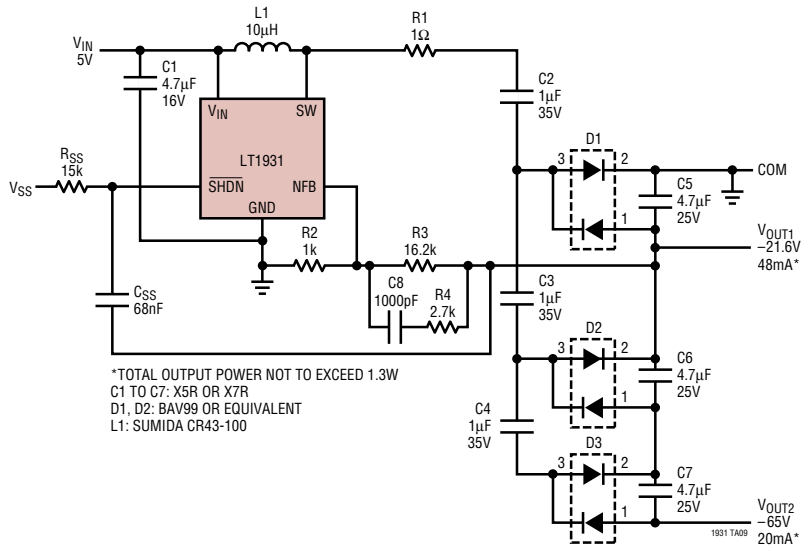


\*TOTAL OUTPUT POWER NOT TO EXCEED 3.3W  
 C1 TO C5: X5R OR X7R  
 D1, D2: BAV99 OR EQUIVALENT  
 L1: SUMIDA CR43-220

1931 TA08

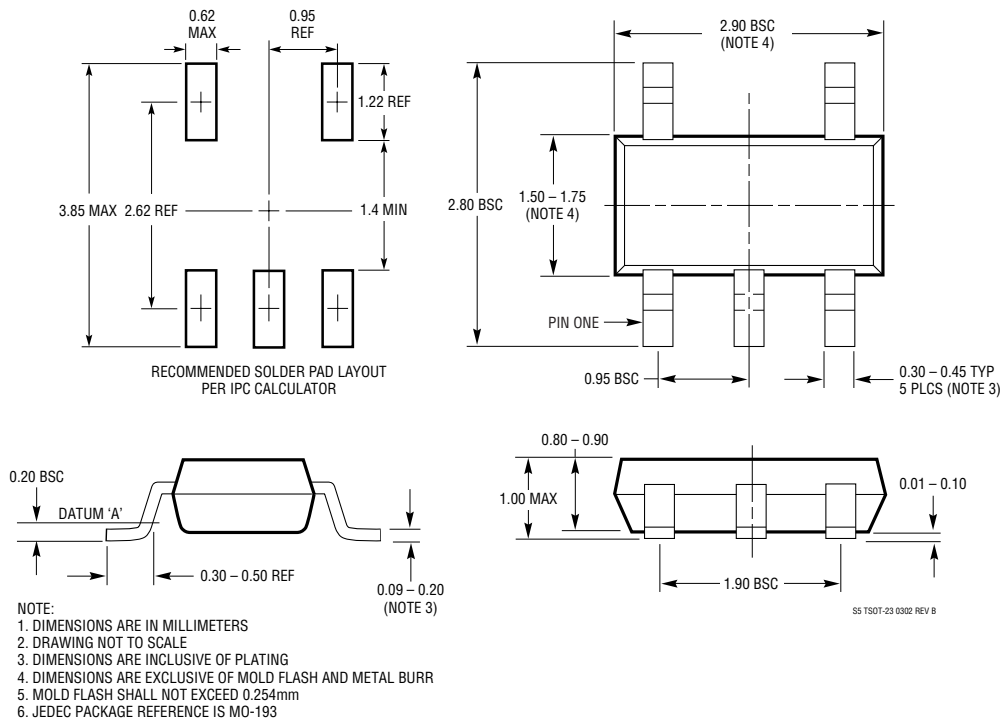
# TYPICAL APPLICATIONS

SLIC Power Supply with -21.6V and -65V Outputs, Uses Soft-Start



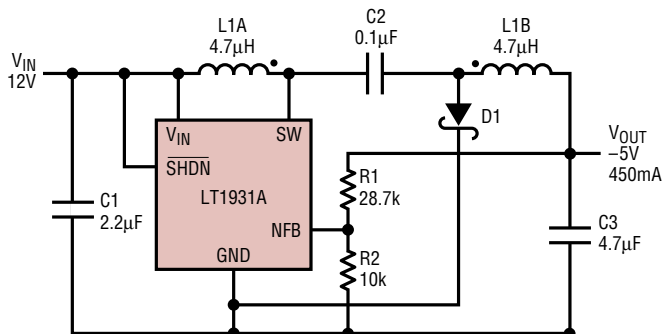
# PACKAGE DESCRIPTION

**S5 Package**  
**5-Lead Plastic TSOT-23**  
 (Reference LTC DWG # 05-08-1635)



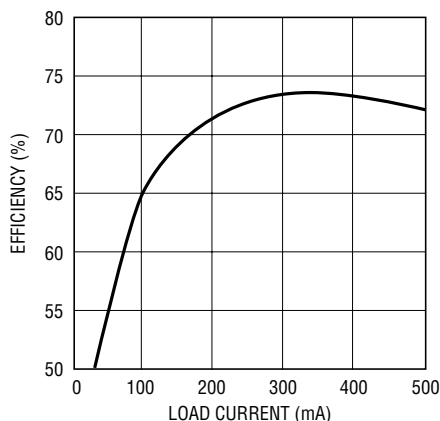
## TYPICAL APPLICATION

### 2.2MHz, 12V to -5V Converter Uses Low Profile Coupled Inductor



C1: TAIYO YUDEN Y5V EMK212F225ZG  
 C2: 0.1µF 25V X5R  
 C3: TAIYO YUDEN X5R JMK212BJ475MG  
 D1: ON SEMICONDUCTOR MBR0520  
 L1: SUMIDA CLQ4D10-4R7 DRAWING #5382-T039

### Efficiency



1931 TA07b

## RELATED PARTS

PART NUMBER	DESCRIPTION	COMMENTS
LT1307	Single Cell Micropower 600kHz PWM DC/DC Converter	3.3V at 75mA from One Cell, MSOP Package
LT1316	Burst Mode™ Operation DC/DC with Programmable Current Limit	1.5V Minimum, Precise Control of Peak Current Limit
LT1317	2-Cell Micropower DC/DC with Low-Battery Detector	3.3V at 200mA from Two Cells, 600kHz Fixed Frequency
LT1610	Single Cell Micropower DC/DC Converter	3V at 30mA from 1V, 1.7MHz Fixed Frequency
LT1611	Inverting 1.4MHz Switching Regulator in 5-Lead ThinSOT	-5V at 150mA from 5V Input. Tiny SOT-23 Package
LT1613	1.4MHz Switching Regulator in 5-Lead ThinSOT	5V at 200mA from 3.3V Input. Tiny SOT-23 Package
LT1615	Micropower Constant Off-Time DC/DC Converter in 5-Lead ThinSOT	20V at 12mA from 2.5V. Tiny SOT-23 Package
LT1617	Micropower Inverting DC/DC Converter in 5-Lead ThinSOT	-15V at 12mA from 2.5V. Tiny SOT-23 Package
LT1930/LT1930A	1.2MHz/2.2MHz, 1A Switching Regulators in 5-Lead ThinSOT	5V at 450mA from 3.3V Input. Tiny SOT-23 Package

Burst Mode operation is a trademark of Linear Technology Corporation.

1931fa

# Mouser Electronics

Authorized Distributor

Click to View Pricing, Inventory, Delivery & Lifecycle Information:

## Analog Devices Inc.:

[LT1931ES5#TRPBF](#) [LT1931AIS5#TRMPBF](#) [LT1931AES5#TRMPBF](#) [LT1931IS5#TRPBF](#) [LT1931ES5#TRMPBF](#)  
[LT1931IS5#TRMPBF](#) [LT1931AES5#TRPBF](#) [LT1931AIS5#TRPBF](#) [DC383B](#)