

## DESCRIPTION

The HI-1590 is a low power CMOS dual +3.3V transceiver with the ability to vary the amplitude of the transmitter outputs. It is designed to meet the requirements of the MIL-STD-1553 / 1760 specifications, and is pin compatible to the HI-1570. The HI-1590 adds SPI communication to the onboard DAC to vary the amplitude of the transmitter outputs.

The transmitter section of each bus takes complementary CMOS / TTL Manchester II bi-phase data and converts it to differential voltages suitable for driving the bus isolation transformer. Separate transmitter inhibit control signals are provided for each transmitter. The user has the option to either supply an external voltage to a single analog input pin, or program an 8-bit DAC through a SPI port to control the transmitter output amplitude.

The receiver section of each bus converts the 1553 bus bi-phase differential data to complementary CMOS / TTL data suitable for inputting to a Manchester decoder. Each receiver has a separate enable input which can be used to force the output of the receiver to a logic "0".

To minimize the package size for this function, the transmitter outputs are internally connected to the receiver inputs so that only two pins are required for connection to each coupling transformer.

## FEATURES

- Compliant to MIL-STD-1553A & B, MIL-STD-1760, ARINC 708A
- CMOS technology for low standby power
- Single +3.3V power supply
- Variable transmitter output amplitude with option to control with an external voltage or SPI controlled 8-bit DAC
- Smallest footprint available in 7mm x 7mm plastic chip-scale (QFN) package with integral heatsink
- Less than 1.2W maximum power dissipation
- Footprint compatible packaging options with HI-1570 or HI-1579
- Industrial and extended temperature ranges
- Industry standard pin configurations

## PIN CONFIGURATIONS

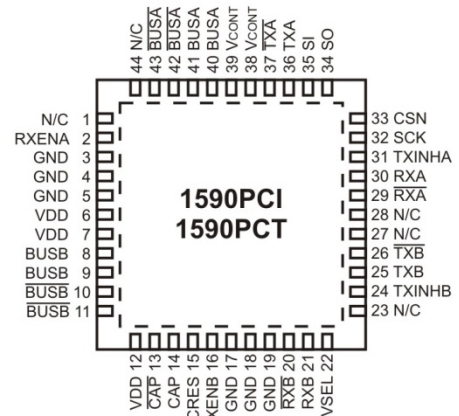

44 Pin Plastic 7mm x 7mm Chip-scale package

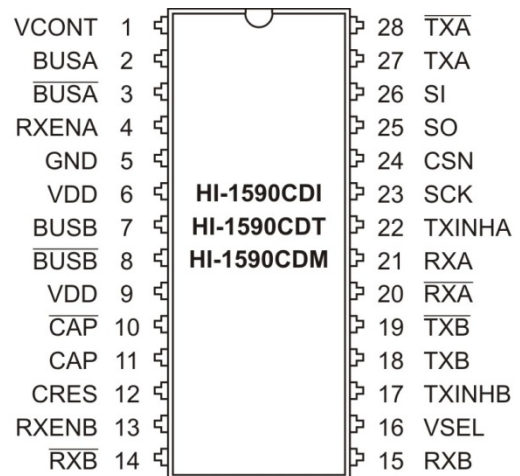

28 – Pin Ceramic Side-Brazed DIP

**BLOCK DIAGRAM**

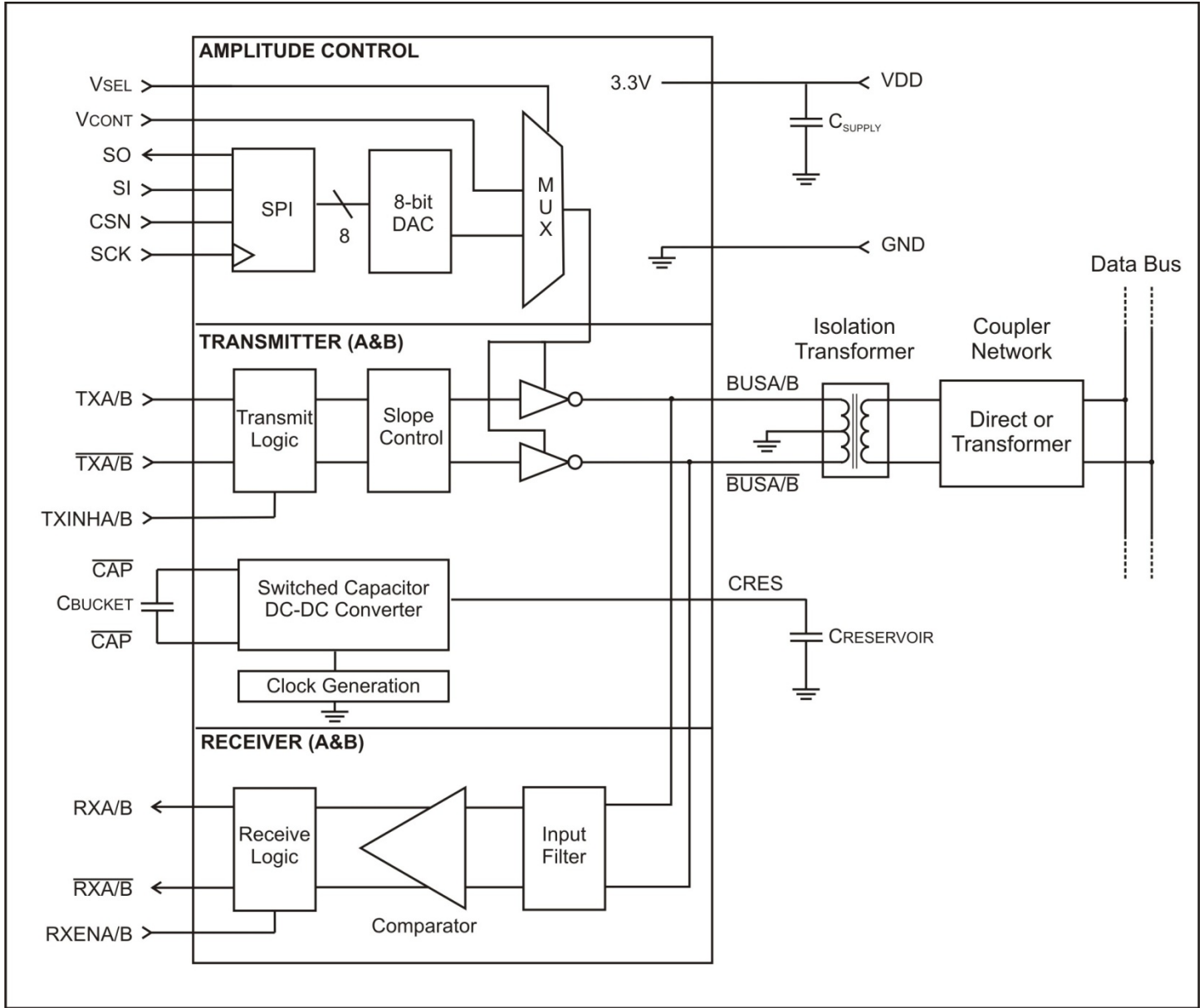

# HI-1590

## PIN DESCRIPTIONS

PIN	SYMBOL	FUNCTION	DESCRIPTION
1	VCONT	Analog input	Transmit output amplitude control (0-3.3 Vdc, see Figure 8)
2	BUSA	Analog output	MIL-STD-1553 bus driver A, positive signal
3	$\overline{\text{BUSA}}$	Analog output	MIL-STD-1553 bus driver A, negative signal
4	RXENA	Digital input	Receiver A enable. If low, forces RXA and $\overline{\text{RXA}}$ low
5	GND	Power supply	Ground for bus A and bus B
6	VDD	Power supply	+3.3 volt power for both bus A and bus B
7	BUSB	Analog output	MIL-STD-1553 bus driver B, positive signal
8	$\overline{\text{BUSB}}$	Analog output	MIL-STD-1553 bus driver B, negative signal
9	VDD	Power supply	+3.3 volt power for both bus A and bus B
10	$\overline{\text{CAP}}$	Analog	Negative connection for external capacitor $C_{\text{BUCKET}}$ . See Table 4 for recommended capacitor type.
11	CAP	Analog	Positive connection for external capacitor $C_{\text{BUCKET}}$ . See Table 4 for recommended capacitor type.
12	CRES	Analog	Positive connection for external capacitor $C_{\text{RESERVOIR}}$ . See Table 4 for recommended capacitor type.
13	RXENB	Digital input	Receiver B enable. If low, forces RXB and $\overline{\text{RXB}}$ low
14	$\overline{\text{RXB}}$	Digital output	Receiver B output, inverted
15	RXB	Digital output	Receiver B output, non-inverted
16	VSEL	Digital input	SPI enable. Tri-level inputs. If low, forces DAC value to control the output amplitude with 0-4.9V range in 19mV step size. If floating, forces VCONT A/B to control output amplitude. If high, forces DAC value to control the output amplitude with 0-26V range in 101mV step size
17	TXINH B	Digital input	Transmit inhibit, bus B. If high BUSB, $\overline{\text{BUSB}}$ disabled
18	TXB	Digital input	Transmitter B digital data input, non-inverted
19	$\overline{\text{TXB}}$	Digital input	Transmitter B digital data input, inverted
20	$\overline{\text{RXA}}$	Digital output	Receiver A output, inverted
21	RXA	Digital output	Receiver A output, non-inverted
22	TXINH A	Digital input	Transmit inhibit, bus A. If high BUSA, $\overline{\text{BUSA}}$ disabled
23	SCK	Digital input	SPI Clock
24	CSN	Digital input	SPI Chip Select, Active Low, internal 30K $\Omega$ pull-up
25	SO	Digital output	SPI serial data output
26	SI	Digital input	SPI serial data input, internal 30K $\Omega$ pull-up
27	TXA	Digital input	Transmitter A digital data input, non-inverted
28	$\overline{\text{TXA}}$	Digital input	Transmitter A digital data input, inverted

## FUNCTIONAL DESCRIPTION

The HI-1590 data bus transceiver contains differential voltage source drivers and differential receivers. They are intended for applications using a MIL-STD-1553 A/B data bus. The device produces a trapezoidal output waveform during transmission.

### TRANSMITTER

Data input to the device's transmitter section is from the complementary CMOS / TTL inputs TXA/B and  $\overline{\text{TXA/B}}$ . The transmitter accepts Manchester II bi-phase data and converts it to differential voltages on BUSA/B and  $\overline{\text{BUSA/B}}$ . The transceiver outputs are either direct or transformer coupled to the MIL-STD-1553 data bus. Both coupling methods produce a nominal voltage on the bus of 7.5 volts peak to peak at VCONT = 3.3 Vdc or maximum 8-bit DAC value 255. Refer to Figure 8 and Figure 9 for transmitter output amplitudes at other values of DAC or VCONT between 0 – 3.3 Vdc.

The transmitter is automatically inhibited and placed in the high impedance state when both TXA/B and  $\overline{\text{TXA/B}}$  are either at a logic "1" or logic "0" simultaneously. A logic "1" applied to the TXINHA/B input will force the transmitter to the high impedance state, regardless of the state of TXA/B and  $\overline{\text{TXA/B}}$ .

### DAC (Digital-to-Analog Converter) and VCONT

The 8 bits written into the SPI register are the input to the DAC. This DAC can control the amplitude of the HI-1590 transmitter output voltage by pulling VSEL high or low according to the following table:

VSEL	Control Source	Output Amplitude Range @ Point $A_T$	Step Size (mV)
High	8-bit DAC via SPI	0 - 26V	101mV
Float	V <sub>CONT</sub> analog via pin 1	0 - 26V	Analog
Low	8-bit DAC via SPI	0 – 4.90V	19mV

When pulling VSEL high, the output amplitude (measured at Point "A<sub>T</sub>" in Figure 7) ranges between 0 – 26 Volts in ~101mV steps as described by the following equation:

$$Y = 0.101x \quad \text{(Equation 1)}$$

Where Y is the output amplitude Vo and x = DAC values  $0 \leq x \leq 255$ . Figure 9 plots this relationship between the DAC value input and the output voltage amplitude.

When pulling VSEL low, the output amplitude (measured at Point "A<sub>T</sub>" in Figure 7) ranges between 0 – 4.90 Volts in ~19mV steps as described by the following equation:

$$Y = 0.019x \quad \text{(Equation 2)}$$

Where Y is the output amplitude Vo, and x = DAC values  $0 \leq x \leq 255$ ). Figure 10 plots this relationship between the DAC value input and the output voltage amplitude.

### RECEIVER

The receiver accepts bi-phase differential data from the MIL-STD-1553 bus through the same direct or transformer coupled interface as the transmitter. The receiver's differential input stage drives a filter and threshold comparator that produces CMOS/TTL data at the RXA/B and  $\overline{\text{RXA/B}}$  output pins.

Each set of receiver outputs can be independently forced to a logic "0" by setting RXENA or RXENB low.

### MIL-STD-1553 BUS INTERFACE

A direct coupled interface (see Figure 4) uses a 1:2.5 ratio isolation transformer and two 55 Ω isolation resistors between the transformer and the bus.

In a transformer coupled interface (see Figure 4), the transceiver is also connected to a 1:1.25 isolation transformer which in turn is connected to a 1:1.4 coupling transformer. The transformer coupled method also requires two coupling resistors equal to 75% of the bus characteristic impedance (Zo) between the coupling transformer and the bus.

### SERIAL PERIPHERAL INTERFACE (SPI) BASICS

The HI-1590 uses an SPI synchronous serial interface for host access to the internal DAC register. Host serial communication is enabled through the Chip Select CSN pin, and is accessed via a three-wire interface consisting of Serial Data Input (SI) from the host, Serial Data output (SO) to the host and Serial Clock (SCK). All read/write cycles are completely self-timed.

The SPI (Serial Peripheral Interface) protocol specifies master and slave operation; the HI-1590 operates as an SPI slave.

The SPI protocol defines two parameters, CPOL (clock polarity) and CPHA (clock phase). The possible CPOL-CPHA combinations define four possible "SPI Modes". Without describing details of the SPI modes, the HI-1590 operates in

# HI-1590

mode 0 where input data for each device (master and slave) is clocked on the rising edge of SCK, and output data for each device changes on the falling edge (CPHA = 0, CPOL = 0). Be sure to set the host SPI logic for mode 0.

As seen in Figure 1, SPI Mode 0 holds SCK in the low state when idle.

The SPI protocol transfers serial data as 8-bit bytes. Once CSN chip select is asserted, the next 8 rising edges on SCK latch input data into the master and slave devices, starting with each byte's most-significant bit. The HI-1590 SPI can be clocked at up to 20MHz.

## HI-1590 SPI COMMANDS

For the HI-1590, each SPI operation is both a read and a simultaneous write. When a host transfers an 8 bit DAC setting, the current byte in the shift register is shifted out and read at the SO pin as the new byte is shifted into the register simultaneously as shown in Figure 1. The newly arrived byte is transferred from the host to the device on the rising edge of CSN.

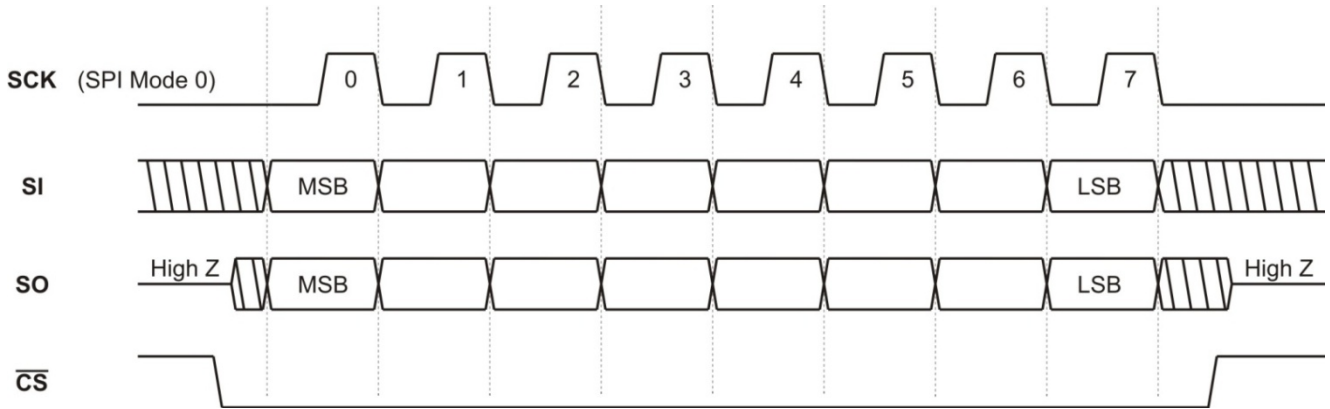

**Figure 1: Single-Byte Transfer using SPI Protocol Mode 0**

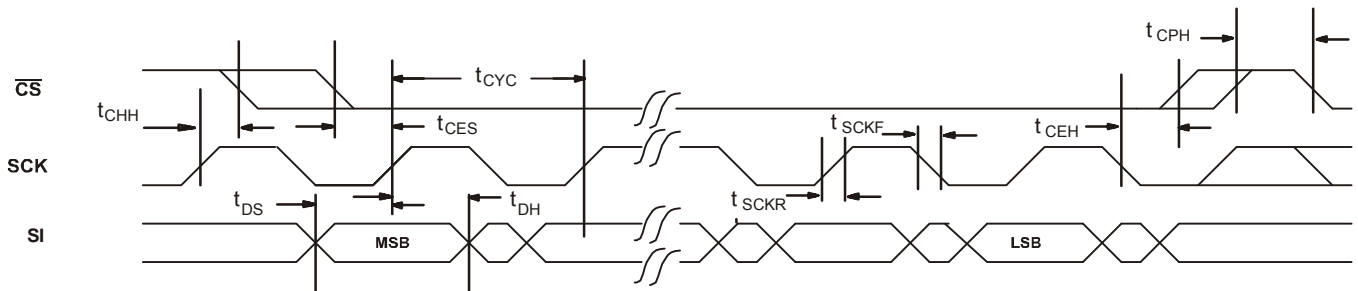

**Figure 2: SPI Serial Input Timing**

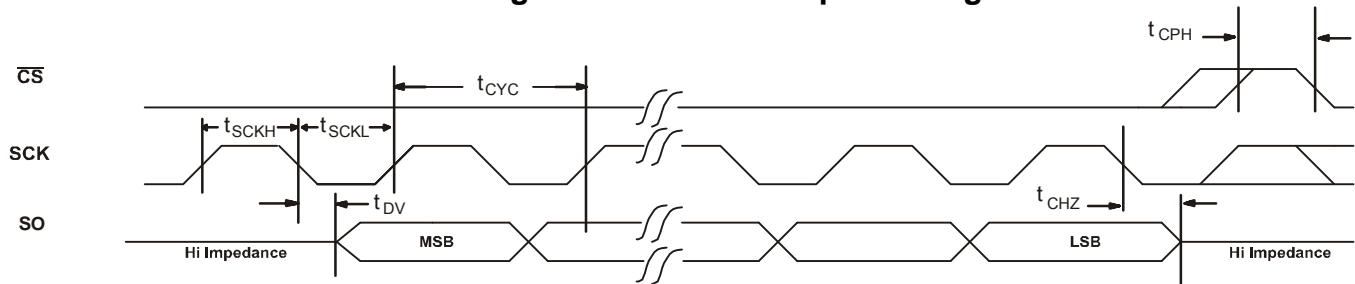

**Figure 3: SPI Serial Output Timing**

# HI-1590

## TRANSMIT WAVEFORM - EXAMPLE PATTERN

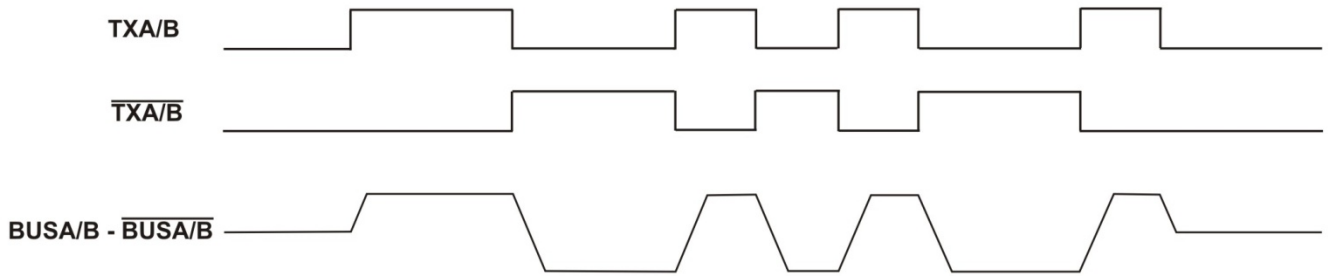

## RECEIVE WAVEFORM - EXAMPLE PATTERN

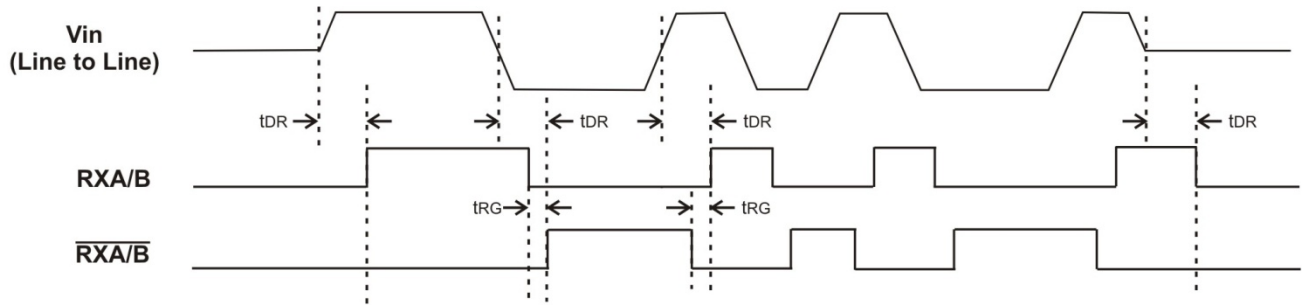

Figure 4: Transmit and Receive Waveforms

# HI-1590

## ABSOLUTE MAXIMUM RATINGS

Supply voltage ( $V_{DD}$ )	-0.3 V to +5 V
Logic input voltage range	-0.3 V DC to +3.6V
Receiver differential voltage	50 Vp-p
Driver peak output current	+1.0 A
Solder Reflow Temperature	260°C
Junction Temperature	175°C
Storage Temperature	-65°C to +150°C

## RECOMMENDED OPERATING CONDITIONS

Supply Voltage	$V_{DD}$ .....3.3V.....±5%
Temperature Range	Industrial .....-40°C to +85°C Extended.....-55°C to +125°C

*NOTE: Stresses above absolute maximum ratings or outside recommended operating conditions may cause permanent damage to the device. These are stress ratings only. Operation at the limits is not recommended.*

## Table 1. DC ELECTRICAL CHARACTERISTICS

$V_{DD} = 3.3V$ ,  $GND = 0V$ ,  $V_{CONT} = 3.3V$ ,  $T_A =$  Operating Temperature Range (unless otherwise specified).

PARAMETER	SYMBOL	CONDITION	MIN	TYP	MAX	UNITS	
Operating Voltage	$V_{DD}$		3.15	3.3	3.45	V	
Total Supply Current	$I_{CC1}$	Not Transmitting		25	40	mA	
	$I_{CC2}$	Transmit one bus @ 50% duty cycle		225	320	mA	
	$I_{CC3}$	Transmit one bus @ 100% duty cycle		750	900	mA	
Power Dissipation	$PD_1$	Not transmitting			0.06	W	
	$PD_2$	Transmit one bus @ 100% duty cycle		0.5	1.0	W	
Min. Input Voltage (HI)	$V_{IH}$	Digital inputs	70%			$V_{DD}$	
Max. Input Voltage (LO)	$V_{IL}$	Digital inputs			30%	$V_{DD}$	
Min. Input Current (HI)	$I_{IH}$	Digital inputs			20	$\mu A$	
Max. Input Current (LO)	$I_{IL}$	Digital inputs	-20			$\mu A$	
Min. Output Voltage (HI)	$V_{OH}$	$I_{OUT} = -1.0mA$ , Digital outputs	90%			$V_{DD}$	
Max. Output Voltage (LO)	$V_{IH}$	$I_{OUT} = 1.0mA$ , Digital outputs			10%	$V_{DD}$	
<b>RECEIVER (Measured at Point "A<sub>D</sub>" in Figure 6 unless otherwise specified)</b>							
Input resistance	$R_{IN}$	Differential (at chip BUS pins)	2			k $\Omega$	
Input capacitance	$C_{IN}$				5	pF	
Common mode rejection ratio	CMRR		40			dB	
Input common mode voltage	$V_{ICM}$		-10.0		10.0	V-pk	
Threshold Voltage – Direct-coupled	Detect	$V_{THD}$	1 MHz Sine Wave (Measured at Point "A <sub>D</sub> " in Figure 6 ) (RX pulse width 70ns)	1.15			V <sub>p-p</sub>
	No Detect	$V_{THND}$	No pulse at RXA/B, RXA/B			0.28	V <sub>p-p</sub>
Threshold Voltage – Transformer-coupled	Detect	$V_{THD}$	1 MHz Sine Wave (Measured at Point "A <sub>T</sub> " in Figure 7) (RX pulse width 70ns)	0.86			V <sub>p-p</sub>
	No Detect	$V_{THND}$	No pulse at RXA/B, RXA/B			0.20	V <sub>p-p</sub>

# HI-1590

## Table 2. DC ELECTRICAL CHARACTERISTICS (cont)

VDD = 3.3V, GND = 0V, VCONT = 3.3V, TA = Operating Temperature Range (unless otherwise specified).

PARAMETER	SYMBOL	CONDITION	MIN	TYP	MAX	UNITS	
<b>TRANSMITTER (Measured at Point "A<sub>D</sub>" in Figure 6 unless otherwise specified)</b>							
Maximum Output Voltage	Direct coupled	V <sub>OUT</sub>	35 Ω load (Measured at Point "A <sub>D</sub> " in Figure 6)	6.1		9.0	V <sub>p-p</sub>
	Transformer coupled	V <sub>OUT</sub>	70 Ω load (Measured at Point "A <sub>T</sub> " in Figure 7)	20.0		28.0	V <sub>p-p</sub>
Output Noise		V <sub>ON</sub>	Differential, inhibited			10	mV <sub>p-p</sub>
Output Dynamic Offset Voltage	Direct coupled	V <sub>DYN</sub>	35 Ω load (Measured at Point "A <sub>D</sub> " in Figure 6)	-90		90	mV
	Transformer coupled	V <sub>DYN</sub>	70 Ω load (Measured at Point "A <sub>T</sub> " in Figure 7)	-250		250	mV
Output resistance		R <sub>OUT</sub>	Differential, not transmitting	10			kΩ
Output Capacitance		C <sub>OUT</sub>	1 MHz sine wave			15	pF
Control Line Resistance		R <sub>CONT</sub>			5		kΩ
DAC Deviation from programmed value		DAC <sub>dev</sub>		-3		+3	bits

## Table 3. AC ELECTRICAL CHARACTERISTICS

VDD = 3.3V, GND = 0V, TA = Operating Temperature Range (unless otherwise specified).

PARAMETER	SYMBOL	CONDITION	MIN	TYP	MAX	UNITS
<b>RECEIVER (Measured at Point "A<sub>T</sub>" in Figure 6)</b>						
Receiver Delay	t <sub>DR</sub>	From input zero crossing to RXA/B or $\overline{RXA/B}$			450	ns
Receiver gap time	t <sub>RG</sub>	Spacing between RXA/B and $\overline{RXA/B}$ pulses 1 MHz sine wave applied at point "AT" Figure 6, amplitude range 0.86 V <sub>p-p</sub> to 27.0V <sub>p-p</sub>	90		365	ns
Receiver Enable Delay	t <sub>REN</sub>	From RXENA/B rising or falling edge to RXA/B or $\overline{RXA/B}$			40	ns
<b>TRANSMITTER (Measured at Point "A<sub>D</sub>" in Figure 6)</b>						
Driver Delay	t <sub>DT</sub>	TXA/B, TXA/B to BUSA/B, $\overline{BUSA/B}$			150	ns
Rise time	t <sub>r</sub>	35 Ω load	100		300	ns
Fall time	t <sub>f</sub>	35 Ω load	100		300	ns
Inhibit Delay	t <sub>dH</sub>	Inhibited output			100	ns
	t <sub>dL</sub>	Active output			150	ns
DAC Settling Time	t <sub>DAC</sub>			50		ms

### SPI INTERFACE TIMING (See Figure 2 & Figure 3)

PARAMETER	SYMBOL	MIN	TYP	MAX	UNITS
SCK clock period	t <sub>CYC</sub>	50			ns
CS active after last SCK rising edge	t <sub>CHH</sub>	5			ns
CS setup time to first SCK rising edge	t <sub>CES</sub>	5			ns
CS hold time after last SCK falling edge	t <sub>CEH</sub>	5			ns
CS inactive between SPI instructions	t <sub>CPH</sub>	55			ns
SPI SI Data set-up time to SCK rising edge	t <sub>DS</sub>	10			ns
SPI SI Data hold time after SCK rising edge	t <sub>DH</sub>	10			ns
SCK rise time	t <sub>SCKR</sub>			10	ns
SCK fall time	t <sub>SCKF</sub>			10	ns
SCK pulse width high	t <sub>SCKH</sub>	20			ns
SCK pulse width low	t <sub>SCKL</sub>	20			ns
SO valid after SCK falling edge	t <sub>DV</sub>			20	ns
SO high-impedance after SCK falling edge	t <sub>CHZ</sub>			20	ns



# HI-1590

## Table 4. DC-DC CONVERTER CHARACTERISTICS

VDD = 3.3V, GND = 0V, TA = Operating Temperature Range (unless otherwise specified).

PARAMETER	SYMBOL	CONDITION	MIN	TYP	MAX	UNITS
Start-up transient	$T_{start}$		-	-	10	ms
Operating Switching Frequency	$f_{sw}$			550		kHz
Recommended Capacitors: X7R dielectric, low ESR, 200m $\Omega$ max. Rated voltage: $\geq 10V$ Material: Ceramic or Tantalum, preferably multilayer.	$C_{BUCKET}$	$C_{RESERVOIR} / C_{BUCKET} \geq 10$	2.2	4.7	-	$\mu F$
	$C_{RESERVOIR}$		22	47	-	$\mu F$
Recommended Capacitor: Rated voltage: $\geq 6.3V$ Material Tantalum	$C_{SUPPLY}$	$C_{SUPPLY} \geq C_{RESERVOIR}$ (connect from VDD to GND)	47	68	-	$\mu F$

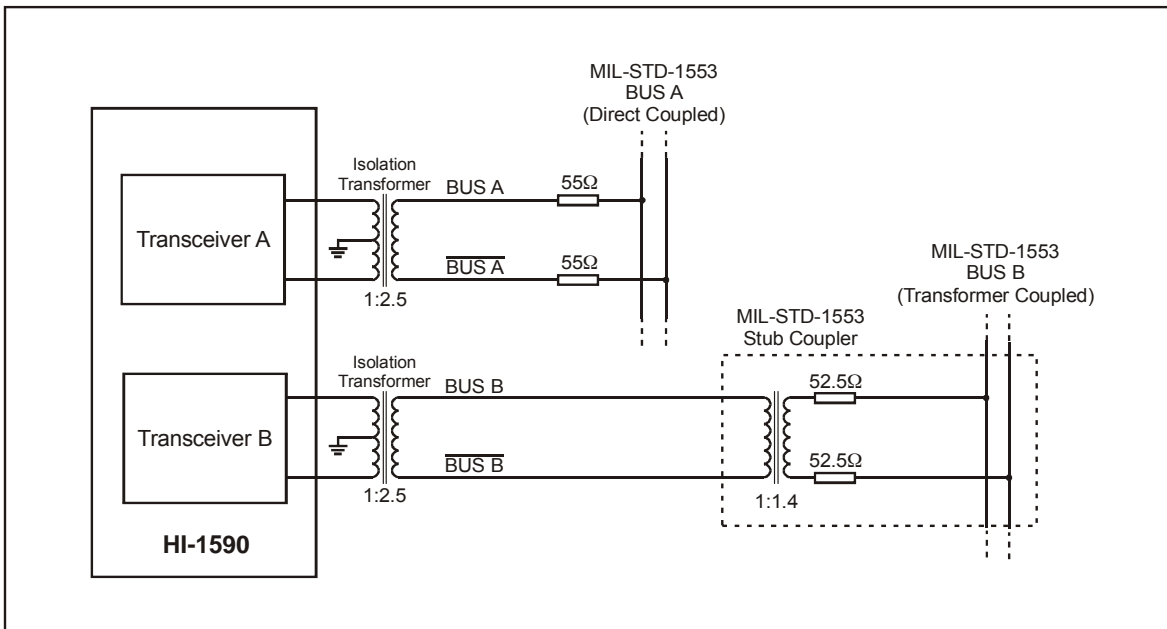

Figure 5: Bus Connection Example

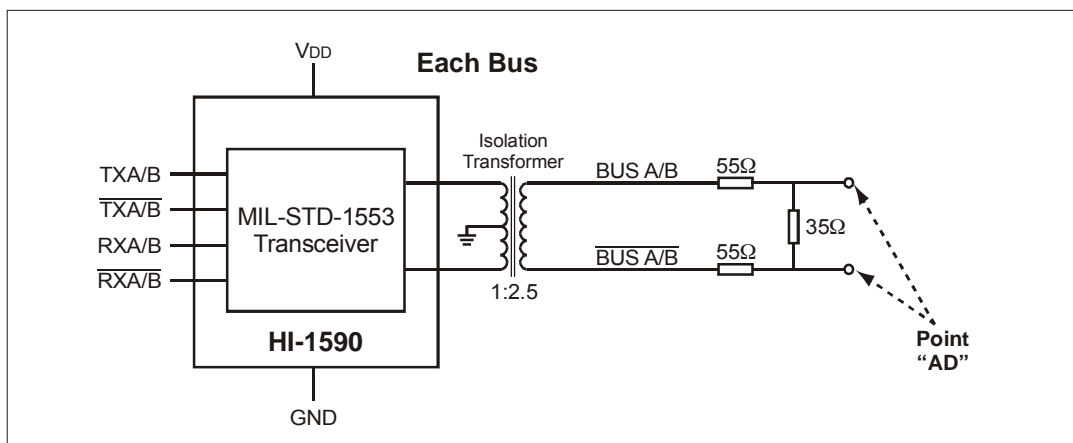
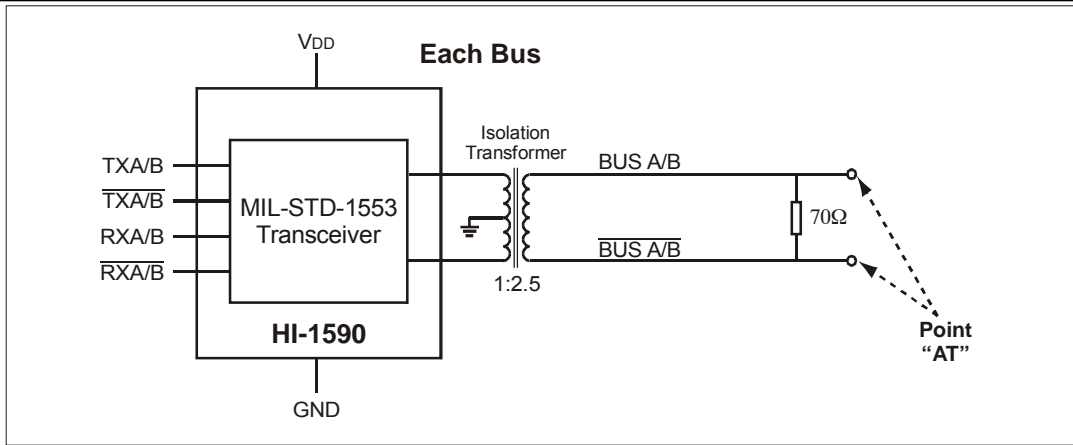
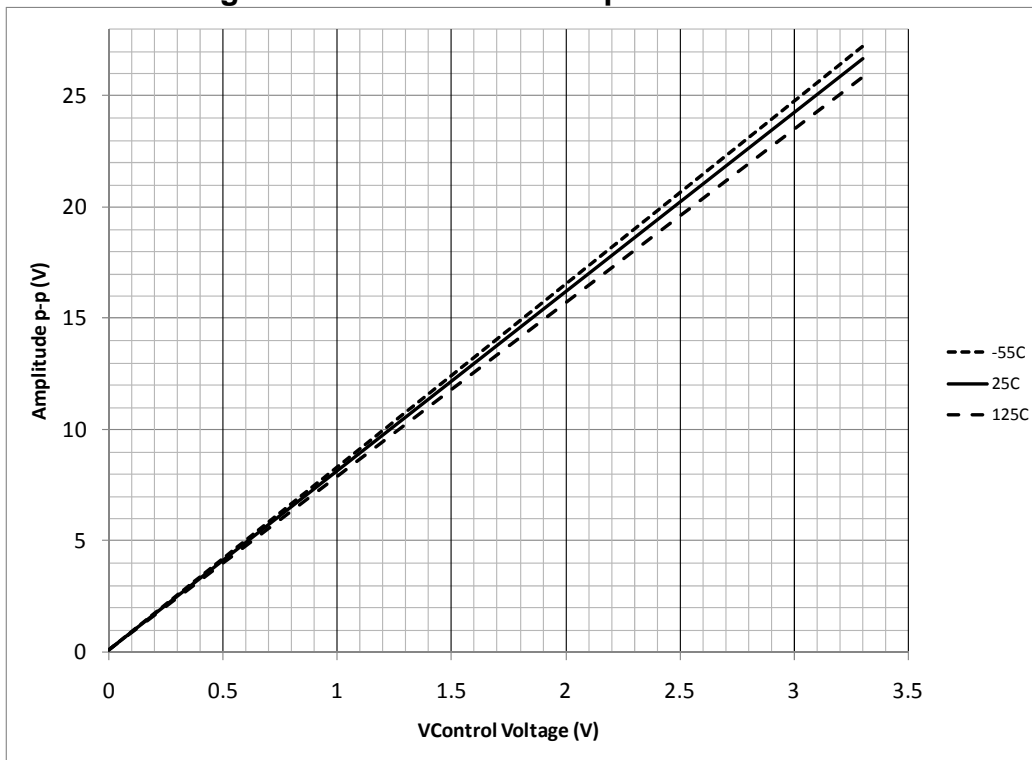

Figure 6: Direct Coupled Test Circuit

# HI-1590



**Figure 7: Transformer Coupled Test Circuit**



**Figure 8: VSEL Float - Transmitter Output Amplitude (Vo) vs. VCONT Voltage ("AT", Figure 6)**

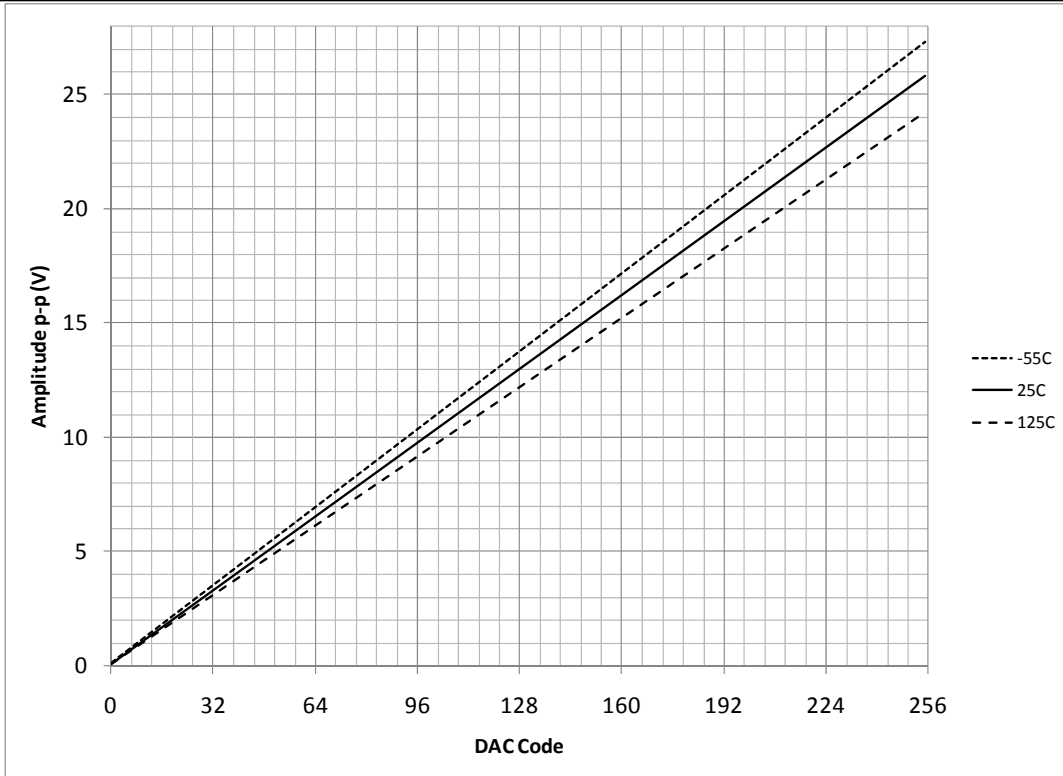

Figure 9: VSEL High - Transmitter Output Amplitude (Vo) vs. DAC value (“AT”, Figure 6)

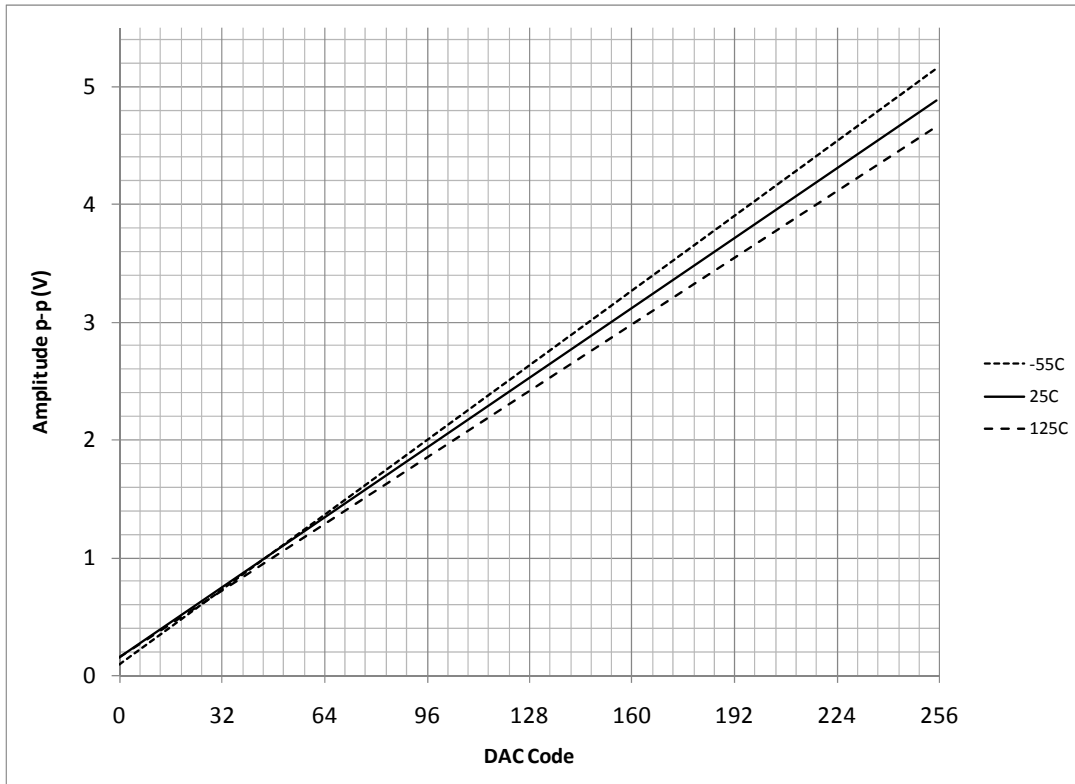
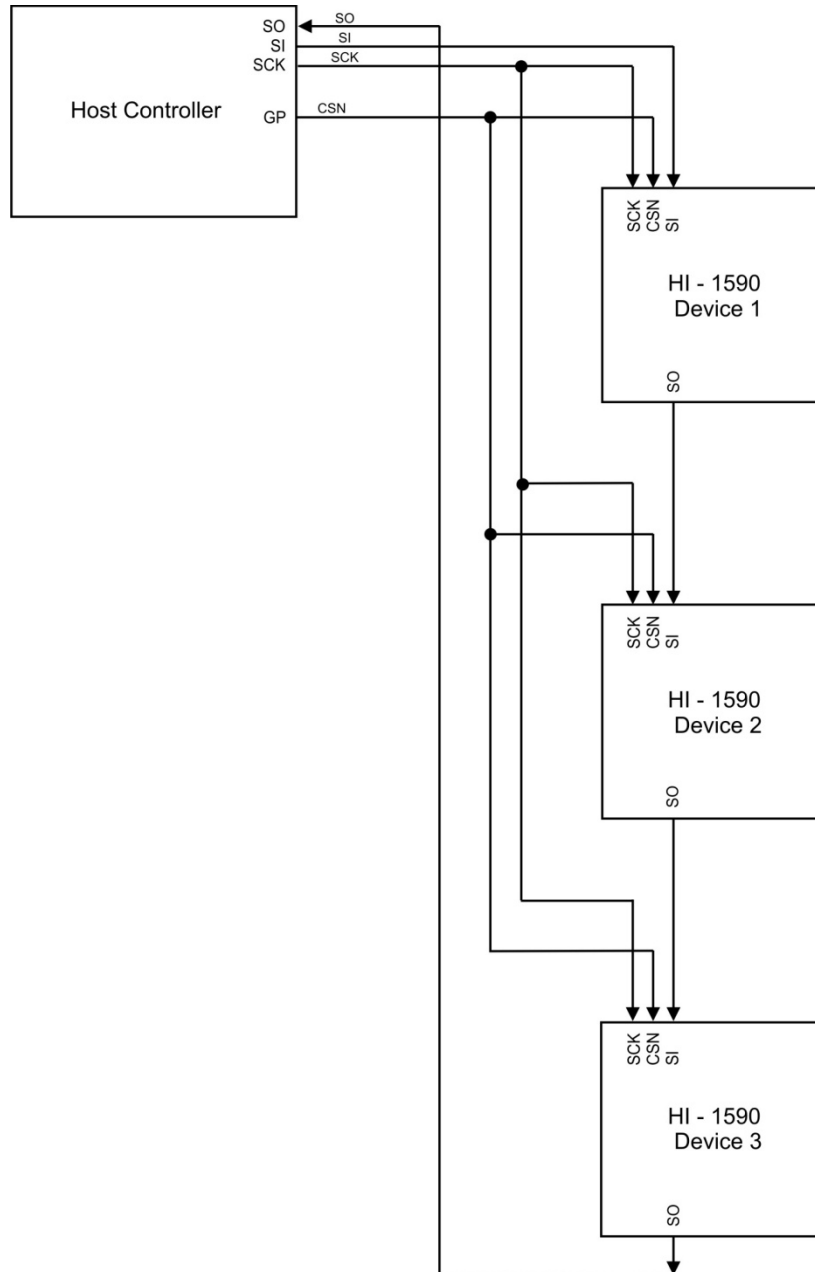

Figure 10: VSEL Low - Transmitter Output Amplitude (Vo) vs. DAC value (“AT”, Figure 6)

## APPLICATIONS NOTE

Holt Applications Note AN-500 provides circuit design notes regarding the use of Holt's family of MIL-STD-1553 transceivers. Layout considerations, as well as recommended interface and protection components are included.

## DAISY CHAIN CONFIGURATION



# HI-1590

**Table 5. THERMAL CHARACTERISTICS**

PART NUMBER	PACKAGE STYLE	CONDITION	θJA	JUNCTION TEMPERATURE		
				TA=25°C	TA=85°C	TA=125°C
HI-1590CDI / T / M HI-1590CDI / T / M	28-pin Ceramic side-brazed DIP	Socketed	62°C/W	72°C	132°C	172°C
HI-1590PCI / T HI-1590PCI / T	44-pin Plastic chip-scale package	Heat sink unsoldered	49°C/W	62°C	122°C	162°C

Data taken at VDD=3.3V, continuous transmission at 1Mbit/s, single transmitter enabled.

**Table 6. RECOMMENDED TRANSFORMERS**

The HI-1590 transceiver has been characterized for compliance with the electrical requirements of MIL-STD-1553 when used with the following transformers. Holt recommends

Premier Magnetics parts as offering the best combination of electrical performance, low cost and small footprint.

MANUFACTURER	PART NUMBER	APPLICATION	TURNS RATIO(S)	DIMENSIONS
Premier Magnetics	PM-DB2702(+) <sup>1</sup>	Stub coupling	1:1.4	.625 x .625 x .250 inches
Premier Magnetics	PM-DB2776(+) <sup>2</sup>	Isolation	Dual ratio 1:2.5	0.675 x 0.4 x 0.185 inches
Premier Magnetics	PM-DB2762(+) <sup>3</sup>	Isolation	Dual ratio 1:2.5	0.4 x 0.4 x 0.330 inches

**Note 1:** Parts with "+" following part number are RoHS compliant.

**Note 2:** Dual side-by-side transformers for low profile.

**Note 3:** Dual stacked transformers for small footprint.

**ORDERING INFORMATION**

**HI-1590PC x x (Plastic)**

PART NUMBER	LEAD FINISH
Blank	Tin/Lead (Sn / Pb) Solder
F	100% Matte Tin (Pb-free, RoHS compliant)

PART NUMBER	TEMPERATURE RANGE	FLOW	BURN IN
I	-40°C to +85°C	I	NO
T	-55°C to +125°C	T	NO

PART NUMBER	RXENA=0		RXENB=0		PACKAGE DESCRIPTION
	RXA	RXA	RXB	RXB	
1590PC	0	0	0	0	44 PIN PLASTIC CHIP-SCALE QFN with optional SPI controlled DAC (not available with 'M' flow)

**HI-1590CD x (Ceramic)**

PART NUMBER	TEMPERATURE RANGE	FLOW	BURN IN	LEAD FINISH
I	-40°C to +85°C	I	NO	Gold (Pb-free, RoHS compliant)
T	-55°C to +125°C	T	NO	Gold (Pb-free, RoHS compliant)
M	-55°C to +125°C	M	YES	Tin/Lead (Sn / Pb) Solder

PART NUMBER	RXENA=0		RXENB=0		PACKAGE DESCRIPTION
	RXA	RXA	RXB	RXB	
1590CD	0	0	0	0	28 PIN CERAMIC SIDE BRAZED DIP (28C) with optional SPI controlled DAC

---

## REVISION HISTORY

---

Document	Rev.	Date	Description of Change
DS1590	NEW	10/16/2014	Initial Release
	A	11/12/2014	Add SPI timing information to AC characteristics. Update SPI Timing Diagram.
	B	01/22/2015	Remove max power dissipation from Maximum Ratings. Remove reference to ESOIC package. Update Recommended Transformers.

---

28-PIN CERAMIC SIDE-BRAZED DIP

inches (millimeters)

Package Type: 28C

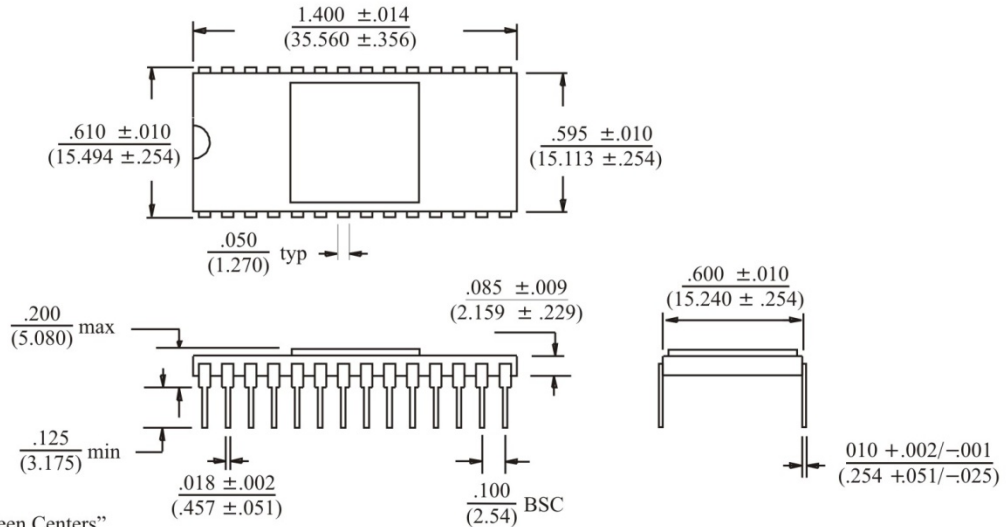

BSC = "Basic Spacing between Centers" is theoretical true position dimension and has no tolerance. (JEDEC Standard 95)

44-PIN PLASTIC CHIP-SCALE PACKAGE (QFN)

millimeters (inches)

Package Type: 44PCS

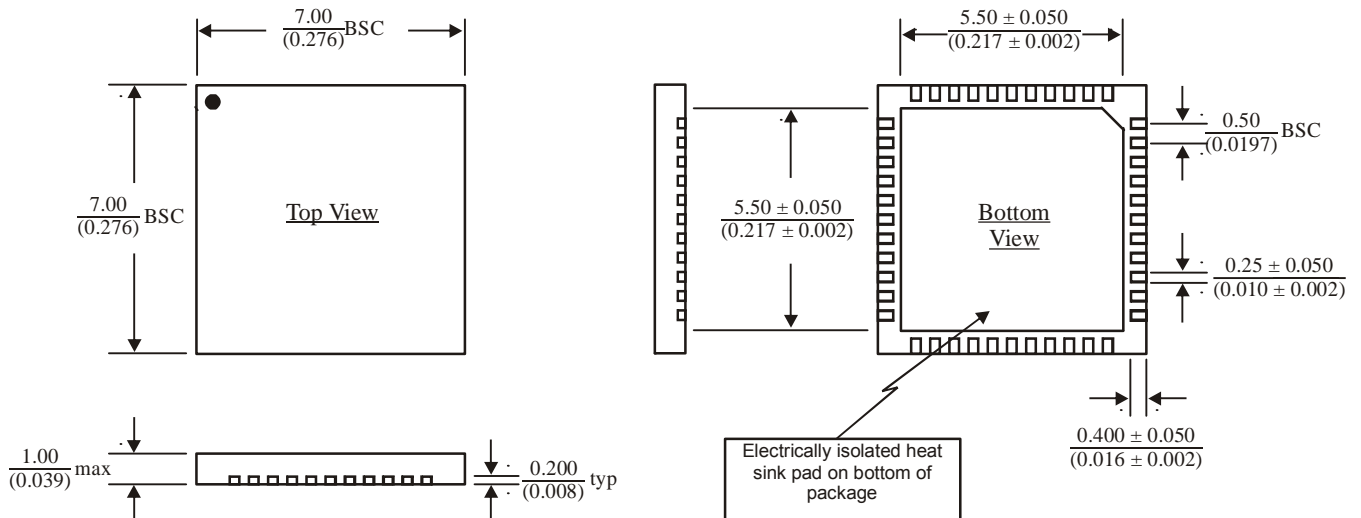

BSC = "Basic Spacing between Centers" is theoretical true position dimension and has no tolerance. (JEDEC Standard 95)