



## A27020 Series

### 256K X 8 OTP CMOS EPROM

---

#### Document Title

256K X 8 OTP CMOS EPROM

#### Revision History

<u>Rev. No.</u>	<u>History</u>	<u>Issue Date</u>	<u>Remark</u>
0.0	Initial issue	August 2, 2002	Preliminary
1.0	Final version release	October 7, 2003	Final
1.1	Change Vpp from 12.75V to 12.25V Modify the program power supply	June 16, 2005	
1.2	Add A27020L-70F Pb-Free type	December 7, 2005	
1.3	Remove non Pb-Free type	October 22, 2010	



# A27020 Series

## 256K X 8 OTP CMOS EPROM

### Features

- 262,144 X 8 bit organization
- Programming voltage: 12.25V
- Access time: 55/70 ns (max.)
- Current: Operating: 30mA (max.) at 5MHz  
Standby: 100µA (max.)
- All inputs and outputs are directly TTL-compatible
- Available in 32-pin DIP and 32-pin PLCC packages
- All Pb-free (Lead-free) products are RoHS compliant

### General Description

The A27020 chip is a high-performance 2,097,152 bit one-time programmable read only memory (OTP EPROM) organized as 256K by 8 bits. The A27020 requires only 5V power supply in normal read mode

operation and any input signals are TTL levels. The A27020 is available in industry standard 32 pin dual-in-line and 32 pin PLCC packages.

### Pin Configurations

#### ■ DIP

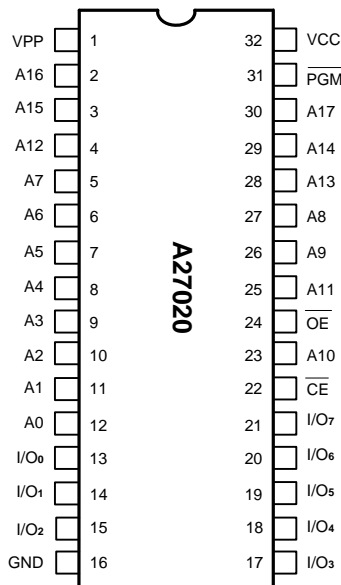

#### ■ PLCC

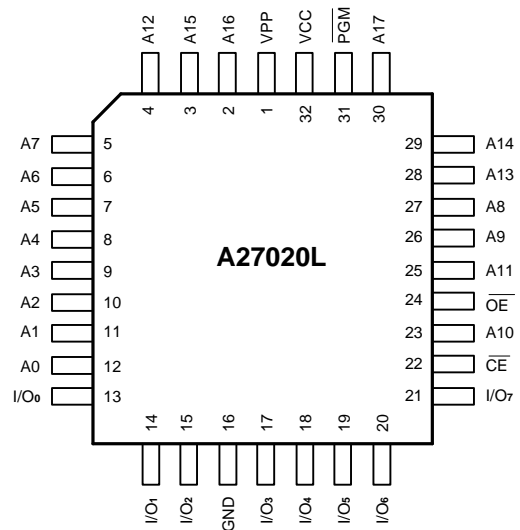

**Pin Configurations**

Pin Name	Function
A0-A17	Address Inputs
I/O7-I/O0	Data Inputs / Outputs
$\overline{\text{CE}}$	Chip Enable
$\overline{\text{OE}}$	Output Enable
$\overline{\text{PGM}}$	Program Strobe
VPP	Program Power Supply
VCC	Power Supply
GND	Ground

**Operating Modes and Truth Table**

Mode	$\overline{\text{CE}}$	$\overline{\text{OE}}$	$\overline{\text{PGM}}$	A0	A1	A9	VPP	VCC	I/O7-I/O0
Read	V <sub>IL</sub>	V <sub>IL</sub>	X	X	X	X	VCC	VCC	Data Out
Output Disable	V <sub>IL</sub>	V <sub>IH</sub>	X	X	X	X	VCC	VCC	Hi-Z
Standby	V <sub>IH</sub>	X	X	X	X	X	VCC	VCC	Hi-Z
Program	V <sub>IL</sub>	V <sub>IH</sub>	V <sub>IL</sub> Pulse	X	X	X	12.25V	5.25V	Data In
Program Verify	V <sub>IL</sub>	V <sub>IL</sub>	V <sub>IH</sub>	X	X	X	12.25V	5.25V	Data Out
Program Inhibit	V <sub>IH</sub>	X	X	X	X	X	12.25V	5.25V	Hi-Z
Manufacturer Code <sup>(3)</sup>	V <sub>IL</sub>	V <sub>IL</sub>	V <sub>IH</sub>	V <sub>IL</sub>	V <sub>IL</sub>	V <sub>ID</sub>	VCC	VCC	37H
Device Code <sup>(3)</sup>	V <sub>IL</sub>	V <sub>IL</sub>	V <sub>IH</sub>	V <sub>IH</sub>	V <sub>IL</sub>	V <sub>ID</sub>	VCC	VCC	64H
Continuation Code <sup>(3)</sup>	V <sub>IL</sub>	V <sub>IL</sub>	V <sub>IH</sub>	V <sub>IL</sub>	V <sub>IH</sub>	V <sub>ID</sub>	VCC	VCC	7FH

**Notes:**

1. X = Either V<sub>IH</sub> or V<sub>IL</sub>.
2. V<sub>ID</sub> = 12V ± 0.5V.
3. A2 ~ A8 = A10 ~ A17 = V<sub>IL</sub> (For auto identification)

## Functional Description

### Read Mode

The A27020 has two control functions, both of which must be logically active in order to obtain data at the outputs.  $\overline{CE}$  is the power control and should be used for device selection.  $\overline{OE}$  is the output control and should be used to data to the output pins, which is independent of device selection. Assuming that addresses are stable, address access time ( $t_{AA}$ ) is equal to the delay from  $\overline{CE}$  to output ( $t_{CE}$ ). Data is available at the output after a delay ( $t_{OE}$ ) from the falling edge of  $\overline{OE}$ , as long as  $\overline{CE}$  has been low and the addresses have been stable for at least  $t_{ACC} - t_{OE}$ .

### Standby Mode

The A27020 has a standby mode which reduces the active current from 30mA to 100 $\mu$ A. The A27020 is placed in the standby mode by applying a CMOS high signal to  $\overline{CE}$ . When in the standby mode, the output are in a high impedance state, independent of the  $\overline{OE}$ .

### Absolute Maximum Ratings\*

Ambient Operating Temperature ( $T_A$ ) . . . . .	-10°C to +85°C
Storage Temperature Plastic Package ( $T_{STG}$ ) . . . . .	55°C to 125°C
Applied Input Voltage ( $V_i$ ):	
All Pins Except A9, VPP and VCC . . . . .	-0.6V to VCC + 0.6V
A9, VPP. . . . .	-0.6V to 12.5V
VCC . . . . .	-0.6V to 7.0V
Output Voltage ( $V_o$ ) . . . . .	-0.6V to 6.0V (Note 1)

#### Notes:

1. During voltage transitions, the input may undershoot GND to -2.0V for periods less than 20 ns. Maximum DC voltage on input and I/O may overshoot to VCC + 2.0V for periods less than 20 ns.
2. When transitions, A9 and VPP may undershoot GND to -2.0V for periods less than 20 ns. Maximum DC input voltage on A9 and VPP is +12.5V which may overshoot to 12.7V for period less than 20 ns.

### Auto Identify Mode

The auto identify mode allows the reading out of a binary code from a EPROM that will identify its manufacturer and type. This mode is intended for use by programming equipment for the purpose of automatically matching the device to be programmed with its corresponding programming algorithm.

To activate the mode, the programming equipment must apply 12.0V  $\pm$  0.5V on address line A9 of the A27020. Three identification code can be read from data output pin by toggling A0 and A1. The other addresses must be held at  $V_{IL}$  during this mode. Byte 0 (with A0 at  $V_{IL}$ , A1 at  $V_{IL}$ ) represents the manufacturer code which is 37H. Byte 1 and Byte 2 represent the device code and continuation code, which is 64H and 7FH respectively. All identifiers for these codes will possess odd parity, with MSB (IO7) defined the parity bit.

### \*Comments

Stresses above those listed under "Absolute Maximum Ratings" may cause permanent damage to this device. These are stress ratings only. Functional operation of this device at these or any other conditions above those indicated in the operational sections of this specification is not implied or intended. Exposure to the absolute maximum rating conditions for extended periods may affect device reliability.

**Read Mode DC Electrical Characteristics** ( $T_a = 0^\circ\text{C}$  to  $70^\circ\text{C}$ ,  $V_{CC} = 5V \pm 10\%$ ,  $V_{PP} = V_{CC}$ )

Symbol	Parameter	Min.	Max.	Unit	Conditions
$V_{OH}$	Output High Voltage	2.4		V	$I_{OH} = -400\mu\text{A}$
$V_{OL}$	Output Low Voltage		0.4	V	$I_{OL} = 2.1\text{mA}$
$V_{IH}$	Input High Voltage	2.0	$V_{CC} + 0.5$	V	
$V_{IL}$	Input Low Voltage	-0.5	0.8	V	
$I_{LI}$	Input Leakage Current	-1	+1	$\mu\text{A}$	$V_{CC} = \text{max.}$ $V_{in} = 0V$ to $V_{CC}$
$I_{LO}$	Output Leakage Current	-1	+1	$\mu\text{A}$	$V_{CC} = \text{max.}$ $V_{out} = 0V$ to $V_{CC}$
$I_{CC}$	VCC Read Operating Current		30	mA	$V_{CC} = \text{max.}$ $\overline{CE} = V_{IL}$ , $\overline{OE} = V_{IL}$ $I_{out} = 0\text{mA}$ , at 5MHz
$I_{SB}$	VCC Standby Current (TTL)		1	mA	$V_{CC} = \text{max.}$ $\overline{CE} = V_{IH}$
$I_{SB1}$	VCC Standby Current (CMOS)		100	$\mu\text{A}$	$V_{CC} = \text{max.}$ $\overline{CE} = V_{CC} - 0.2V$
$I_{PP}$	VPP Current During Read		10	$\mu\text{A}$	$\overline{CE} = \overline{OE} = V_{IL}$ , $V_{PP} = V_{CC}$
$I_{ID}$	A9 Auto Select Current		100	$\mu\text{A}$	$A9 = V_{ID}$ , $V_{CC} = \text{max.}$

**Capacitance** ( $T_A = 25^\circ\text{C}$ ,  $f = 1.0\text{MHz}$ )

Symbol	Parameter	Min.	Max.	Unit	Conditions
$C_{IN}$	Input Capacitance		8	pF	$V_{IN} = 0V$
$C_{out}$	Output Capacitance		8	pF	$V_{out} = 0V$

\* These parameters are sampled and not 100% tested.

**Read Mode AC Characteristics** ( $T_a = 0^\circ\text{C}$  to  $70^\circ\text{C}$ ,  $V_{CC} = 5V \pm 10\%$ ,  $V_{PP} = V_{CC}$ )

Symbol	Parameter	55ns		70ns		Unit
		Min.	Max.	Min.	Max.	
$t_{CYC}$	Cycle Time	55		70		ns
$t_{AA}$	Address Access Time		55		70	ns
$t_{CE}$	Chip Enable Access Time		55		70	ns
$t_{OE}$	Output Enable Access Time		30		35	ns
$t_{OH}$	Output Hold after Address, $\overline{CE}$ or $\overline{OE}$ , whichever Occurred First	0		0		ns
$t_{HZ}$	Output High Z Delay		20		20	ns

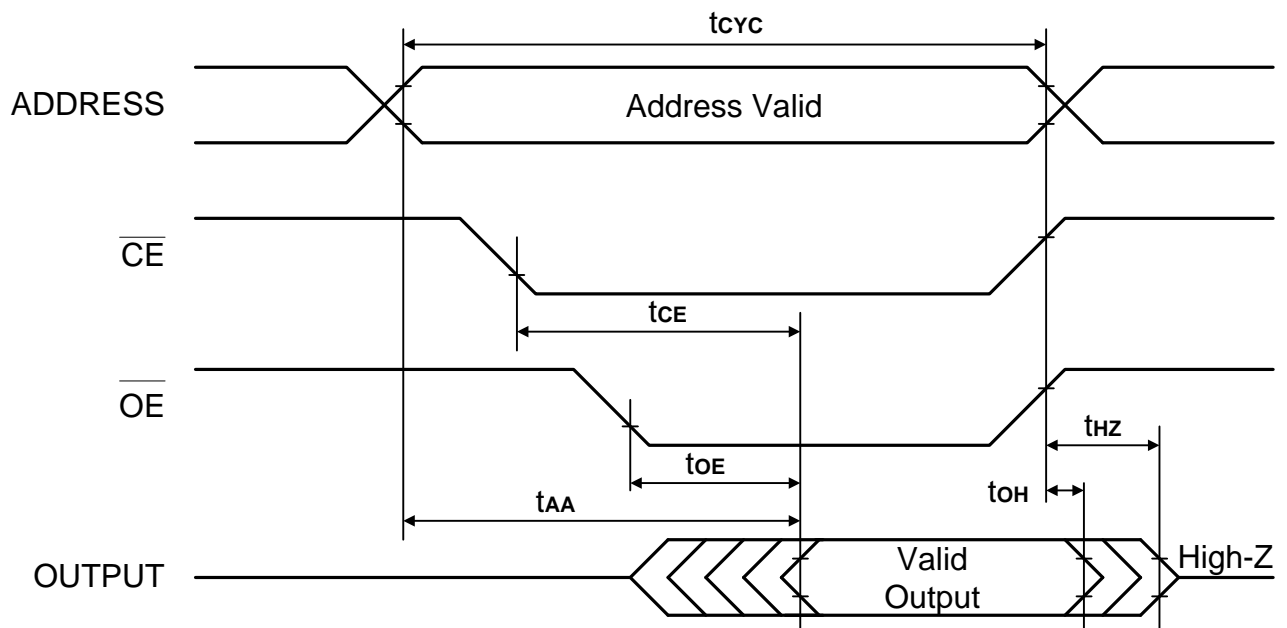
**Read Mode Switching Waveforms**

**AC Measurement Conditions**

- for 55 ns
- ① Input Rise and Fall Times  $\leq 10$  ns
  - ② Input Pulse Voltage: 0V to 3V
  - ③ Input and Output Timing Ref. Voltage: 1.5V

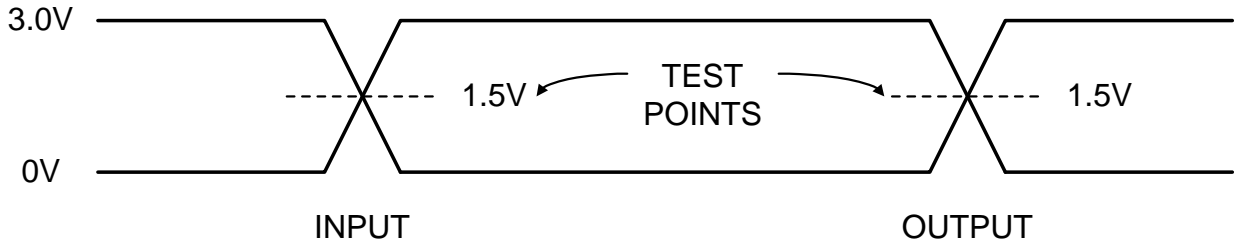

- for 70 ns
- ① Input Rise and Fall Times  $\leq 10$  ns
  - ② Input Pulse Voltage: 0.4V to 2.4V
  - ③ Input and Output Timing Ref. Voltage: 0.8V to 2.0V

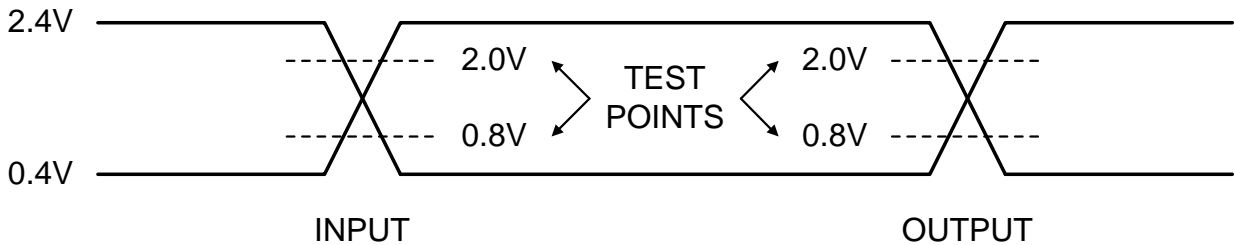
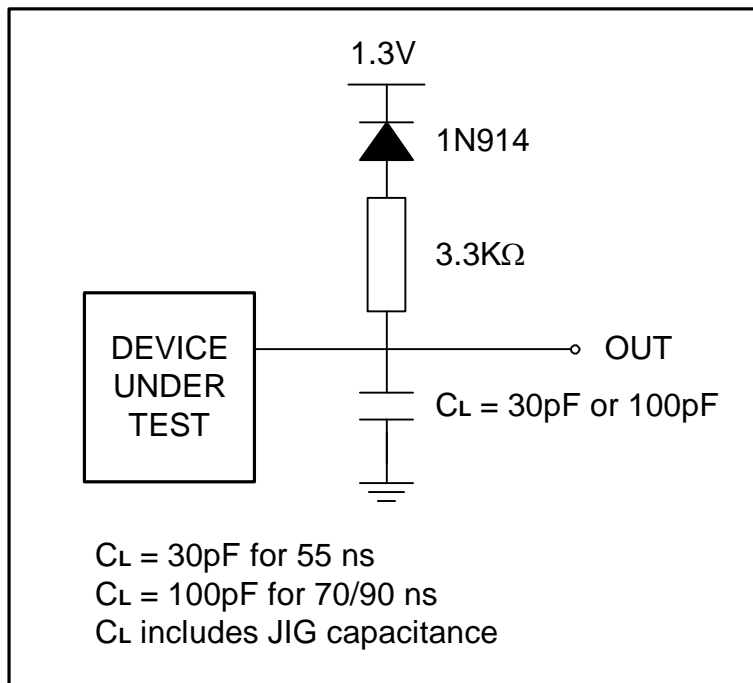
**AC Testing Load Circuit**

### Programming and Program Verify

The programming flowchart is shown in Page 10.

The A27020 is shipped with all bits being set to "1". Programming causes relevant bits to be changed to "0". The programming mode is started by setting VCC to +5.25V and VPP to +12.25V, while  $\overline{CE}$  and  $\overline{PGM}$  are at  $V_{IL}$ , and  $\overline{OE}$  is at  $V_{IH}$ . Data to be programmed can be directly input in the 8 bit format through the data bus.

The write programming algorithm reduces programming time by using 100 $\mu$ s pulse followed by a byte verification to determine whether the byte has been successfully programmed. If the data does not pass the

verification, an additional pulse programming is applied for a maximum of 25 pulses. On completion of 1 byte programming and, The verified address is incremented. After the final address is completed, all bytes are verified again with VCC = 5.0 Volt.

### Program Inhibit

This mode is used to program one of multiple A27020 whose  $\overline{OE}$ ,  $\overline{PGM}$ , VPP, VCC, address bus and data bus are connected in parallel. When programming is performed, other A27020 can be inhibited from being programmed by setting their  $\overline{CE}$  pins to  $V_{IH}$ .

### Programming Mode DC Characteristics (Ta = 0°C to 70°C, VCC = 5.25V $\pm$ 0.25V, VPP = 12.25V $\pm$ 0.25V)

Symbol	Parameter	Min.	Max.	Unit	Test Conditions
V <sub>OH</sub>	Output High Voltage	2.4		V	I <sub>OH</sub> = -400 $\mu$ A
V <sub>OL</sub>	Output Low Voltage		0.4	V	I <sub>OL</sub> = 2.1mA
V <sub>IH</sub>	Input High Voltage	2.0	VCC + 0.5	V	
V <sub>IL</sub>	Input Low Voltage	-0.5	0.8	V	
I <sub>LI</sub>	Input Leakage Current	-1	+1	$\mu$ A	VCC = max. Vin = 0V to VCC
I <sub>CC</sub>	VCC Current During Program		50	mA	
I <sub>PP</sub>	VPP Current During Program		50	mA	$\overline{CE} = V_{IL}$
V <sub>ID</sub>	A9 Auto Select Voltage	11.5	12.5	V	A9 = V <sub>ID</sub>
VCC1	Programming Supply Voltage	5.0	5.5	V	
VPP1	Programming Voltage	12.0	12.5	V	

Note: VCC must be applied simultaneously or before VPP and removed simultaneously or after VPP.



**Programming Mode AC Characteristics** ( $T_a = 0^\circ\text{C}$  to  $70^\circ\text{C}$ ,  $V_{CC} = 5.25\text{V} \pm 0.25\text{V}$ ,  $V_{PP} = 12.25\text{V} \pm 0.25\text{V}$ )

Symbol	Parameter	Min.	Max.	Unit
t <sub>AS</sub>	Address Valid to Program Low	2		μs
t <sub>DS</sub>	Input Valid to Program Low	2		μs
t <sub>VPS</sub>	V <sub>PP</sub> High to Program Low	2		μs
t <sub>VCS</sub>	V <sub>CC</sub> High to Program Low	2		μs
t <sub>CES</sub>	$\overline{\text{CE}}$ Low to Program Low	2		μs
t <sub>PW</sub>	Program Pulse Width	95	105	μs
t <sub>DH</sub>	Program High to Input transition	2		μs
t <sub>OES</sub>	Input Transition to $\overline{\text{OE}}$ Low	2		μs
t <sub>OE</sub>	$\overline{\text{OE}}$ Low to Output Valid		100	ns
t <sub>OHZ</sub>	$\overline{\text{OE}}$ High to Output Hi-Z		130	ns
t <sub>AH</sub>	$\overline{\text{OE}}$ High to Address Transition	0		ns

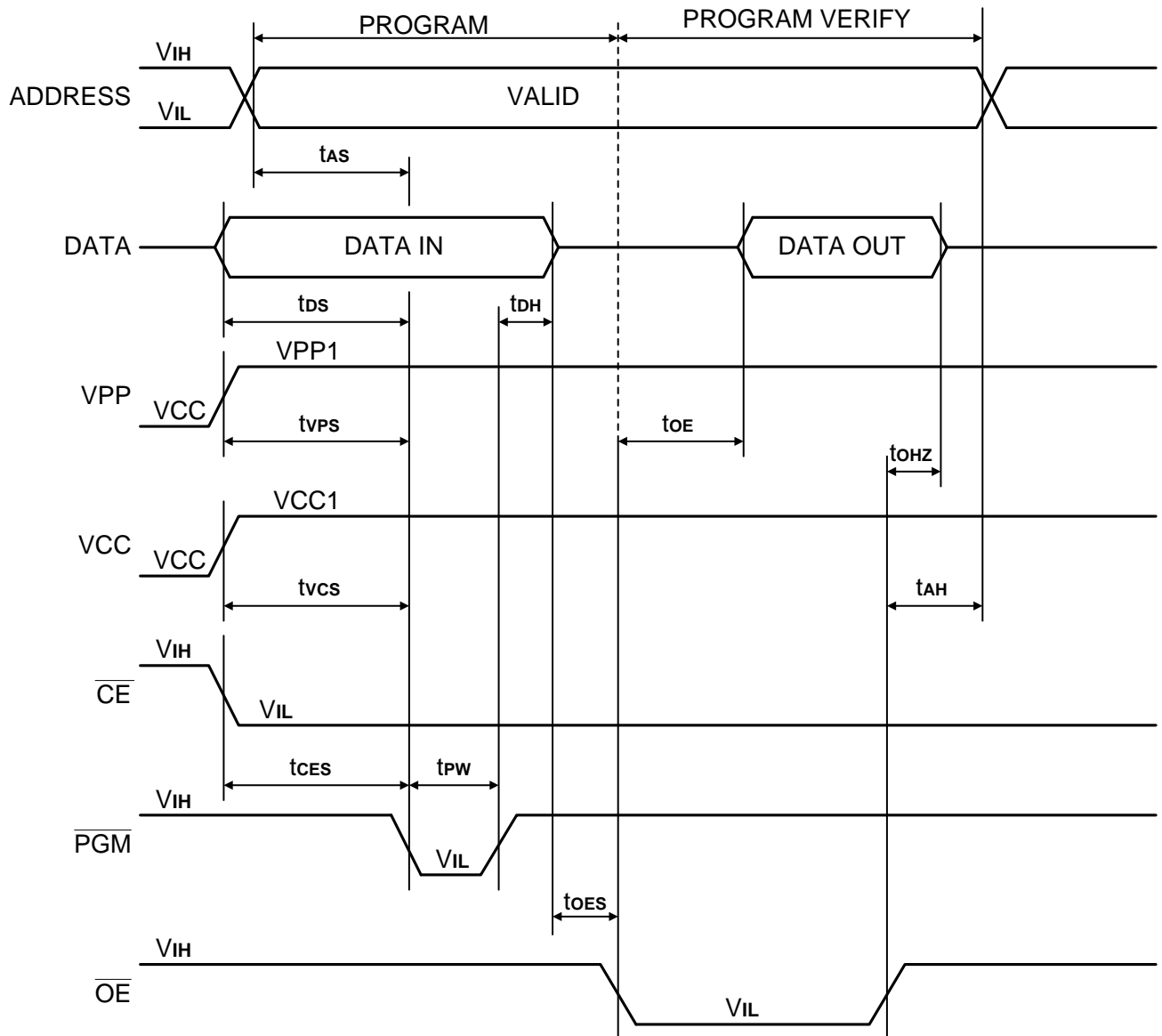
**Programming and Verify Mode AC Waveforms**

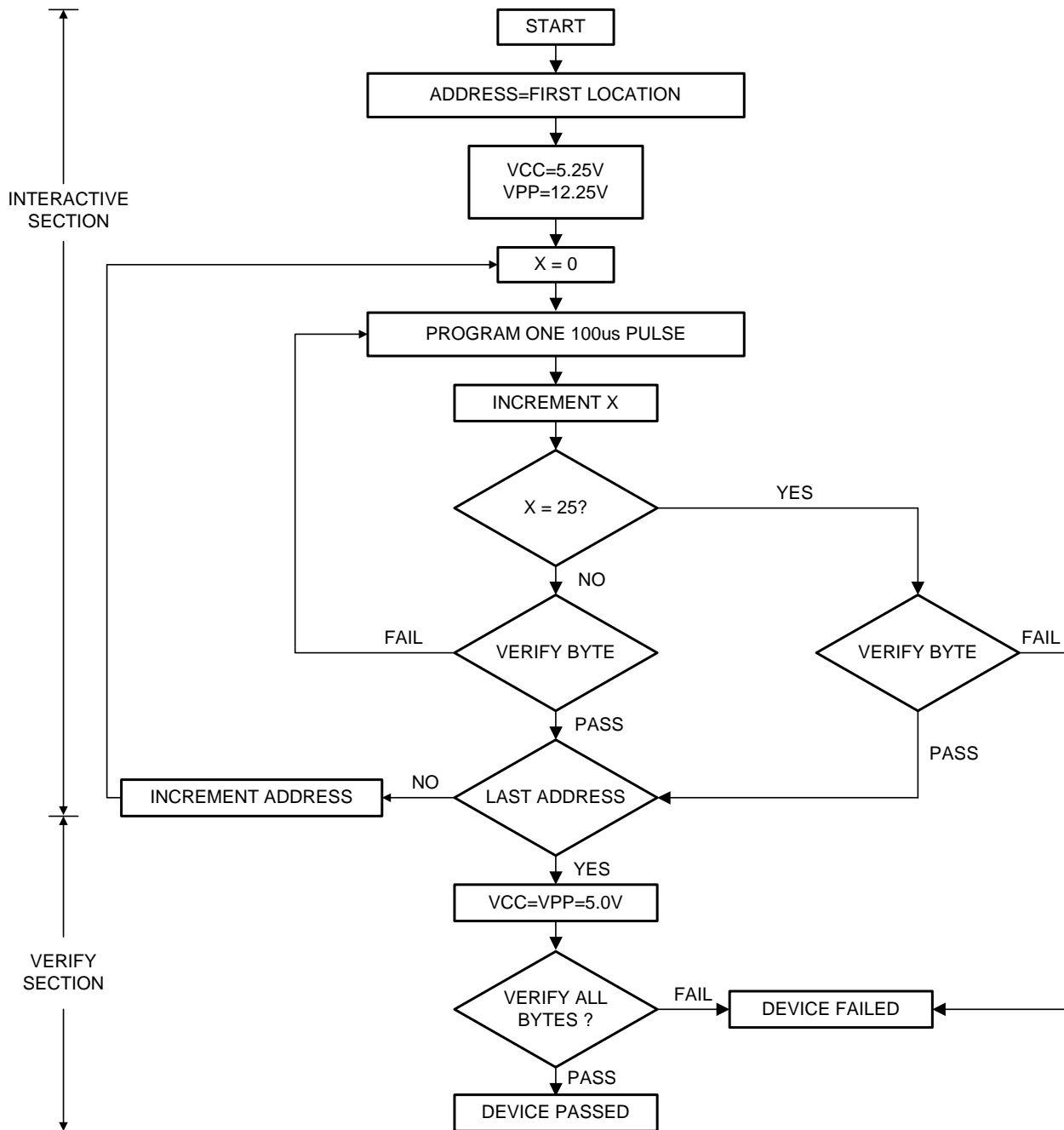
**Programming Flowchart**

**Ordering Information**

<b>Part No.</b>	<b>Access Time (ns)</b>	<b>Operating Current Max. (mA) at 5MHz</b>	<b>Standby Current Max. (μA)</b>	<b>Package</b>
A27020-55F	55	30	100	32Pin Pb-Free DIP
A27020L-55F	55	30	100	32Pin Pb-Free PLCC
A27020-70F	70	30	100	32Pin Pb-Free DIP
A27020L-70F	70	30	100	32Pin Pb-Free PLCC

**Package Information**
**P-DIP 32L Outline Dimensions**

unit: inches/mm

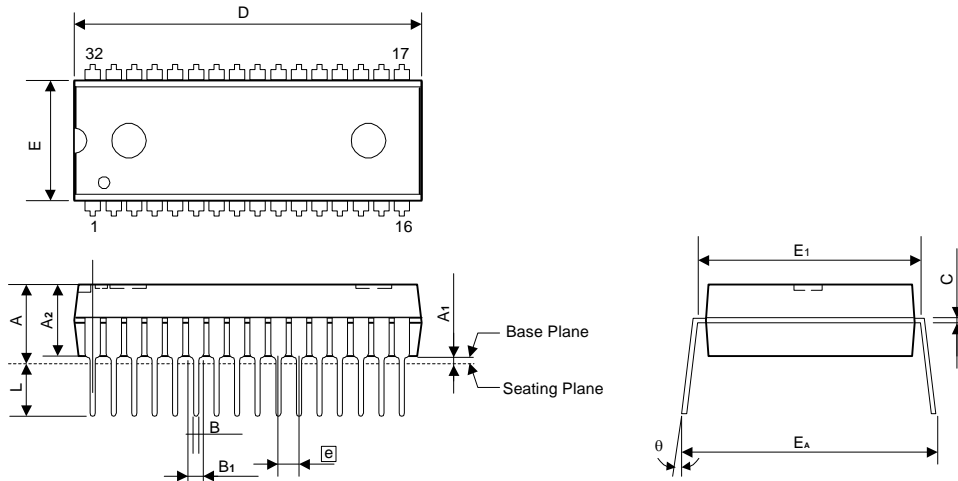

Symbol	Dimensions in inches			Dimensions in mm		
	Min	Nom	Max	Min	Nom	Max
A	-	-	0.210	-	-	5.334
A1	0.015	-	-	0.381	-	-
A2	0.149	0.154	0.159	3.785	3.912	4.039
B	-	0.018	-	-	0.457	-
B1	-	0.050	-	-	1.270	-
C	-	0.010	-	-	0.254	-
D	1.645	1.650	1.655	41.783	41.91	42.037
E	0.537	0.542	0.547	13.64	13.767	13.894
E1	0.590	0.600	0.610	14.986	15.240	15.494
EA	0.630	0.650	0.670	16.002	16.510	17.018
$\boxed{e}$	-	0.100	-	-	2.540	-
L	0.120	0.130	0.140	3.048	3.302	3.556
$\theta$	0°	-	15°	0°	-	15°

**Notes:**

1. The maximum value of dimension D includes end flash.
2. Dimension E does not include resin fins.

**Package Information**
**PLCC 32L Outline Dimension**

unit: inches/mm

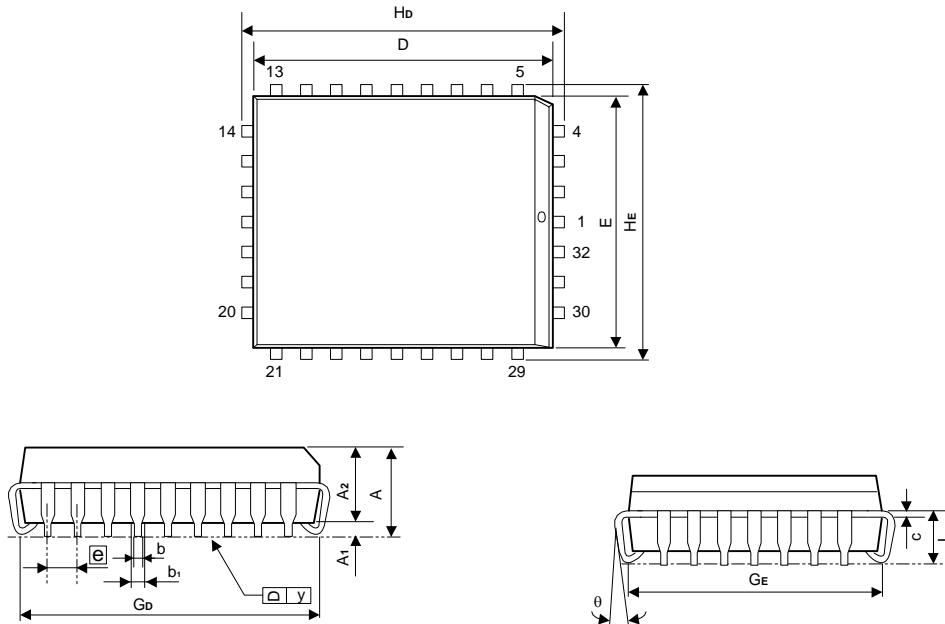

Symbol	Dimensions in inches			Dimensions in mm		
	Min	Nom	Max	Min	Nom	Max
A	-	-	0.134	-	-	3.40
A1	0.0185	-	-	0.47	-	-
A2	0.105	0.110	0.115	2.67	2.80	2.93
$b_1$	0.026	0.028	0.032	0.66	0.71	0.81
b	0.016	0.018	0.021	0.41	0.46	0.54
C	0.008	0.010	0.014	0.20	0.254	0.35
D	0.547	0.550	0.553	13.89	13.97	14.05
E	0.447	0.450	0.453	11.35	11.43	11.51
$\bar{e}$	0.044	0.050	0.056	1.12	1.27	1.42
$G_D$	0.490	0.510	0.530	12.45	12.95	13.46
$G_E$	0.390	0.410	0.430	9.91	10.41	10.92
$H_D$	0.585	0.590	0.595	14.86	14.99	15.11
$H_E$	0.485	0.490	0.495	12.32	12.45	12.57
L	0.075	0.090	0.095	1.91	2.29	2.41
y	-	-	0.003	-	-	0.075
$\theta$	0°	-	10°	0°	-	10°

**Notes:**

- Dimensions D and E do not include resin fins.
- Dimensions  $G_D$  &  $G_E$  are for PC Board surface mount pad pitch design reference only.