

ISL91302B

Dual/Single Output Power Management IC

FN8828
Rev.3.01
Feb 2, 2022

The [ISL91302B](#) is a highly efficient, dual or single output, synchronous multiphase buck switching regulator that can deliver up to 5A per phase continuous output current. The ISL91302B features four integrated power stages and two controllers. The ISL91302B can assign its power stages and controllers to two dual-phase outputs (2+2) or one three-phase and one-phase output (3+1) or one four-phase output (4+0). This flexibility allows seamless design-in for a wide range of applications in which dual, triple, or quad phase outputs are needed, such as CPU and GPU core power mobile applications.

The ISL91302B integrated low ON-resistance MOSFETs, programmable PWM frequency, and automatic diode emulation, which maximizes efficiency while minimizing the external component count and solution size.

The ISL91302B uses the proprietary Renesas R5 modulator technology to deliver a highly robust power solution capable of ultra-fast transient response, excellent loop stability, and seamless DCM/CCM transitions without requiring external compensation.

The ISL91302B is widely configurable through the factory OTP settings. Available features include:

- SPI and I²C interface
- External signal telemetry with an internal ADC
- Dynamic Voltage Scaling (DVS) with selectable slew rate

Contact Renesas [support](#) for additional configurations.

Features

- Dual output 3+1 or 2+2, or single output 4-phase
- 2.5V to 5.5V supply voltage
- 5A per phase output current capability
- Small solution size
- High efficiency (94.7% peak for 3.8V V_{IN}, 1.8V V_{OUT}, L = 470nH)
- Low I_Q in low power mode
- Proprietary control scheme reduces the output capacitor and supports fast load transients (such as 50A/μs per phase)
- Voltage, current, and temperature telemetry through integrated ADC plus auxiliary inputs
- ±0.7% system accuracy with remote voltage sensing
- OTP programmable PWM frequency from 2MHz to 6MHz
- I²C and SPI programmable output from 0.3V to 2.0V
- Independent Dynamic Voltage Scaling (DVS) for each output
- Soft-start and fault detection (UV, OV, OC, OT), short-circuit protection
- 2.551mm x 3.670mm 54 ball WLCSP with 0.4mm pin pitch

Applications

- Smart phones and tablets
- FPGA and ASIC power
- Industrial MPU power
- Human machine interface

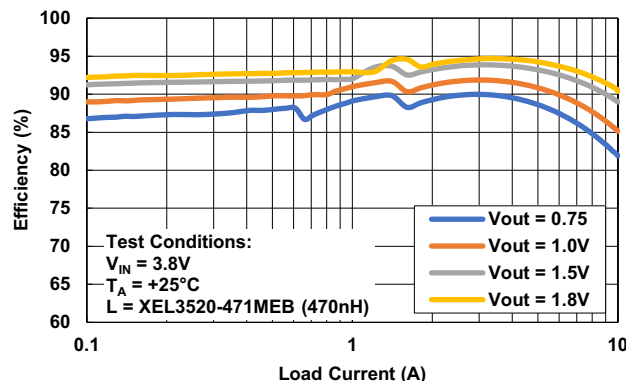

Figure 1. 2-Phase Configuration Efficiency

Contents

1. Overview	4
1.1 Typical Application Circuits	4
1.2 Block Diagram	6
1.3 Ordering Information	7
1.4 Pin Configuration	8
1.5 Pin Descriptions	9
2. Specifications	11
2.1 Absolute Maximum Ratings	11
2.2 Thermal Information	11
2.3 Recommended Operation Conditions	11
2.4 Analog Specifications	12
3. Output Configurations	15
4. Typical Operating Performance	18
5. Applications Information	21
5.1 Inductor Selection	21
5.2 Output Capacitor Selection	21
5.3 Input Capacitor Selection	22
5.4 ADC Telemetry	22
5.5 Dynamic Voltage Scaling (DVS)	23
5.6 Configuring DVS Speed	26
5.7 Output Voltage Setting	26
5.8 Power Sequencing	26
5.9 Watchdog Time (WDOG_RST Pin)	28
5.10 Interrupt Pin	28
5.11 Decay Mode	29
6. Protection Features (Faults)	30
6.1 Over-Temperature Protection	30
6.2 Overcurrent Protection Mode	30
6.3 Overvoltage (OV)/Undervoltage (UV) Protection	30
7. Serial Communication Interface	31
7.1 SPI Serial Interface	31
7.2 I ² C Interface	34
8. Board Layout Recommendations	38
8.1 PCB Layout Summary	40
8.2 PCB Design for WLCSP Recommendations	40

9.	Register Address Map	41
10.	Register Description by Address	42
11.	Revision History	78
12.	Package Outline Drawing	79

1. Overview

1.1 Typical Application Circuits

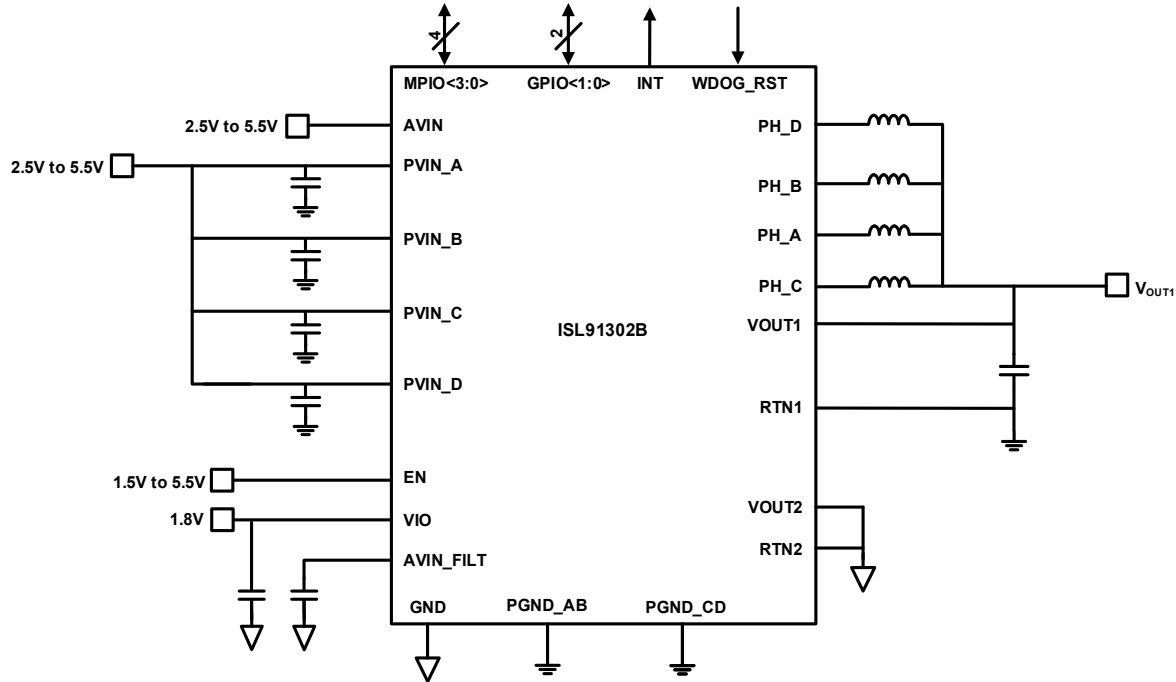

Figure 2. Typical Application 4-Phase Single Output

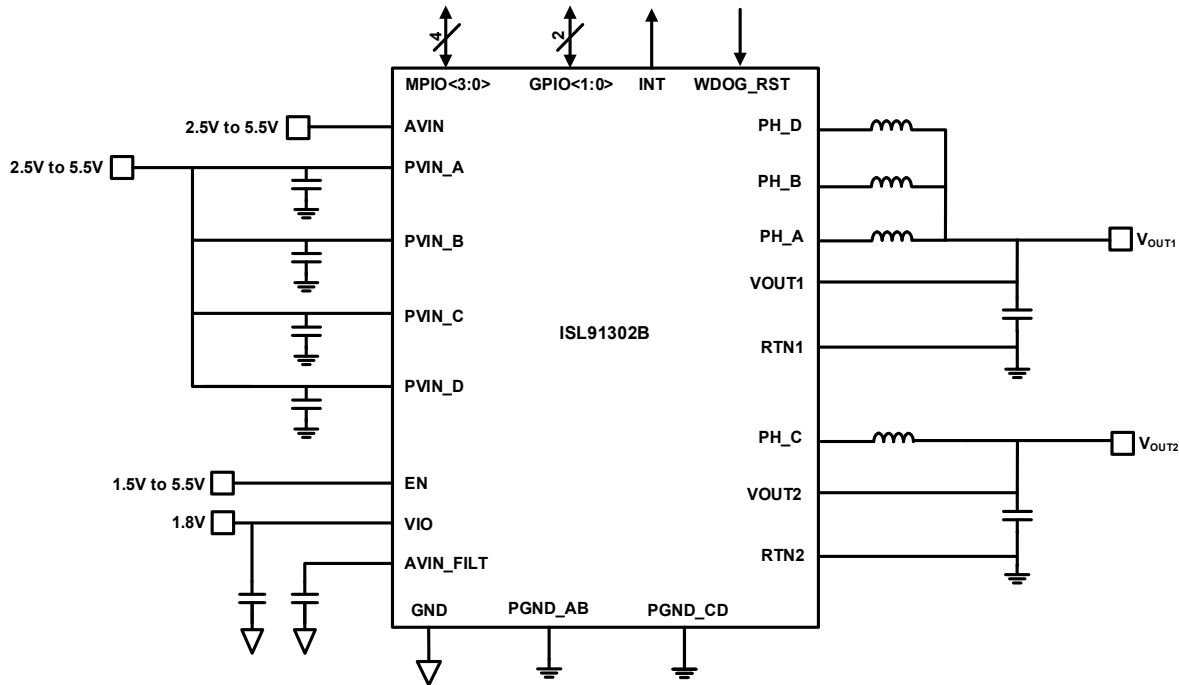

Figure 3. Typical Application Circuit: 3-Phase + 1-Phase

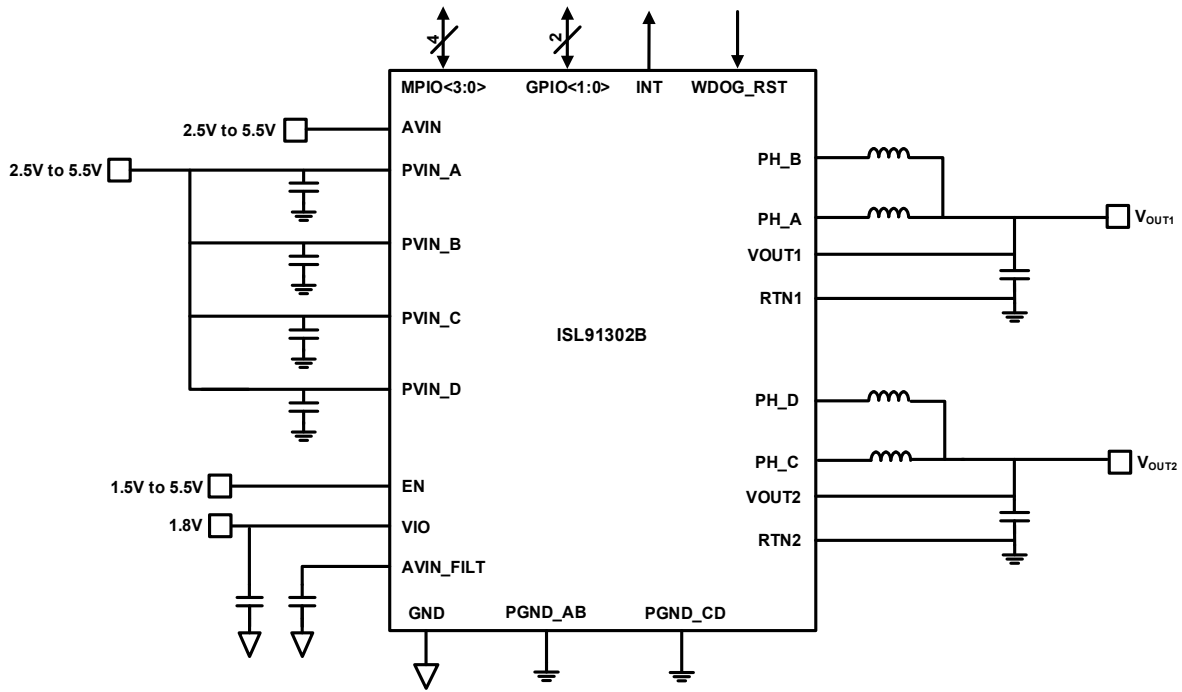

Figure 4. Typical Application Circuit: 2-Phase + 2-Phase

1.2 Block Diagram

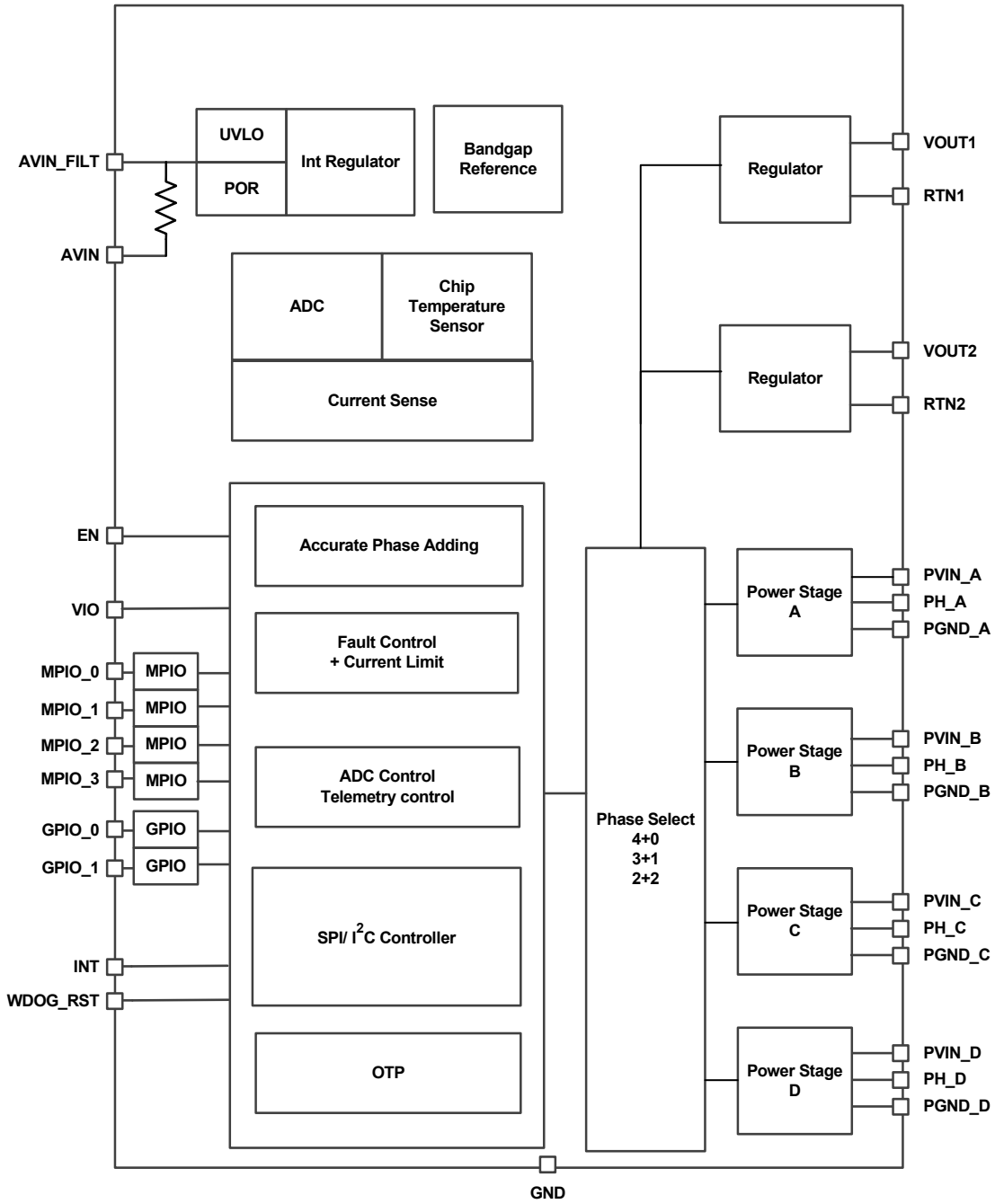

Figure 5. Block Diagram

1.3 Ordering Information

Part Number (Notes 1, 3, 4)	Part Marking	Package Description (RoHS Compliant)	Pkg. Dwg. #	Carrier Type (Note 2)	Temp Range
ISL91302BIIZ-T	91302B	2.551mmx3.670mm, 54 Ball 6x9 WLCSP	W6x9.54	Reel, 3k	-40 to +85°C
ISL91302B22-EVZ	ISL91302B - Evaluation board 1, 2+2 PMIC, WLCSP RoHS compliant				
ISL91302B31-EVZ	ISL91302B - Evaluation board 1, 3+1 PMIC, WLCSP RoHS compliant				
ISL91302B40-EVZ	ISL91302B - Evaluation board 1, 4+0 PMIC, WLCSP RoHS compliant				

Notes:

- For additional part options contact your local sales office.
- See [TB347](#) for details about reel specifications.
- These Pb-free WLCSP packaged products employ special Pb-free material sets; molding compounds/die attach materials and SnAgCu - e6 solder ball terminals, which are RoHS compliant and compatible with both SnPb and Pb-free soldering operations. Pb-free WLCSP packaged products are MSL classified at Pb-free peak reflow temperatures that meet or exceed the Pb-free requirements of IPC/JEDEC J-STD-020.
- For Moisture Sensitivity Level (MSL), see the [ISL91302B](#) device page. For more information about MSL, see [TB363](#).

Table 1. Key Differences Between Family of Parts

Part Number	Pin Configuration	Pitch	Output Configuration	Maximum Load
ISL91302B	54 Ball 6x9 WLCSP	0.4mm	Single Output (4 + 0 Phase)	5A
	54 Ball 6x9 WLCSP	0.4mm	Dual Output (3 + 1 Phase)	5A
	54 Ball 6x9 WLCSP	0.4mm	Dual Output (2 + 2 Phase)	5A
ISL91301A	42 Ball 6x7 WLCSP	0.4mm	Triple Output (2+1+1 Phase)	4A
ISL91301B	42 Ball 6x7 WLCSP	0.4mm	Quad Output (1+1+1+1 Phase)	4A
ISL91211A	54 Ball 6x9 WLCSP	0.4mm	Triple Output (2+1+1 Phase)	5A
ISL91211B	54 Ball 6x9 WLCSP	0.4mm	Quad Output (1+1+1+1 Phase)	5A

1.4 Pin Configuration

54 Bump 6x9 WLCSP
Top View

JEDEC Standard:
Balls Down, A1 Top Left Corner



1.5 Pin Descriptions

Pin Number	Pin Name	Type	Description
A1, B1	PVIN_A	Input	Power supply for Power Stage A.
A2, B2, C2	PH_A	Output	Switching node for Power Stage A.
A3, B3, C3	PGND_A	Input	Ground connection for Power Stage A.
A4, B4, C4	PGND_B	Input	Ground connection for Power Stage B.
A5, B5, C5	PH_B	Input	Switching node for Power Stage B.
A6, B6	PVIN_B	Input	Power supply for Power Stage B.
C1	GPIO0	Input/Output	General purpose I/O pin, see Table 2 .
C6	WDOG_RST	Input	Digital input, resets the bucks to default output voltage.
D1	EN	Input	Master chip enable input, NMOS logic threshold.
D2	GPIO1	Input/Output	General purpose I/O pin, see Table 2 .
D3	INT	Output	Interrupt line.
D4, D5, E2, E3, E4, E5	GND	Input	Analog chip ground. Ensure a low impedance connection to the internal ground layer.
D6	RTN1	Input	Remote ground voltage sense for Buck #1.
E1	VOUT2	Input	Remote output voltage sense for Buck #2.
E6	VOUT1	Input	Remote output voltage sense for Buck #1.
F1	RTN2	Input	Remote ground voltage sense for Buck #2.
F2	AVIN_FILT	Output	Filtered analog supply voltage, 2.5 to 5.5V. Place a decoupling capacitor close to the IC.
F3	VIO	Input	I/O supply voltage for digital communications. Normally connected to 1.8V supply.
F4	MPIO0	Input/Output	Multipurpose I/O, see Table 2 .
F5	MPIO1		
F6	MPIO2		
G1	AVIN	Input	Analog supply voltage, 2.5V to 5.5V.
G2, H2, J2	PH_C	Output	Switching node for Power Stage C.
G3, H3, J3	PGND_C	Input	Ground connection for Power Stage C.
G4, H4, J4	PGND_D	Input	Ground connection for Power Stage D.
G5, H5, J5	PH_D	Output	Switching node for Power Stage D.
G6	MPIO3	Input/Output	Multipurpose I/O, see Table 2 .
H1, J1	PVIN_C	Input	Power supply connection for Power Stage C.
H6, J6	PVIN_D	Input	Power supply connection for Power Stage D.

Table 2. I/O Pin Configuration

IO_PINMODE	MPIO0	MPIO1	MPIO2	MPIO3	GPIO0	GPIO1	Description
0x0	SCK	SS_B	MOSI	MISO	SCL	SDA	I ² C/SPI both available
0x1	SCK	SS_B	MOSI	MISO	EN_A	EN_B	SPI mode with hardware buck enable pins
0x2	Reserved	Reserved	Reserved	Reserved	Reserved	Reserved	Reserved
0x3	SCK	SS_B	MOSI	MISO	DVS1_0	DVS2_0	SPI with hardware DVS pins
0x4	DVS_PIN1	DVS_PIN0	PGOOD1	PGOOD2	SCL	SDA	I ² C with global DVS mode with PGOOD1 and PGOOD2

Table 2. I/O Pin Configuration (Continued)

IO_PINMODE	MPIO0	MPIO1	MPIO2	MPIO3	GPIO0	GPIO1	Description
0x5	DVS1_0	DVS1_1	DVS2_0	DVS2_1	SCL	SDA	I ² C with full pin controlled DVS for Buck1 and Buck2
0x6	DVS1_0	DVS2_0	PGOOD1	PGOOD2	SCL	SDA	I ² C with DVS and PGOOD for Buck1 and Buck2
0x7- 0xC	Reserved	Reserved	Reserved	Reserved	Reserved	Reserved	Reserved
0xD	ADC_IN0	ADC_IN1	PGOOD1	PGOOD2	SCL	SDA	I ² C with ADC input and PGOOD for Buck1 and Buck2
0xE	ADC_IN0	ADC_IN1	DVS_PIN1	DVS_PIN0	SCL	SDA	I ² C with ADC input and global DVS
0xF	Reserved	Reserved	Reserved	Reserved	Reserved	Reserved	Reserved

Table 3. Pin Mode Name Description

Name	Definition
SCK	SPI clock.
SS_B	SPI slave select (must be pulled to VIO when using I ² C in Pin Mode 0x0)
MOSI	SPI master out slave in.
MISO	SPI master in slave out.
SCL	I ² C clock.
SDA	I ² C data.
PGOOD1, PGOOD2	Power-good output pins.
EN_A, EN_B	Buck enable input pins.
DVS_PIN1, DVS_PIN0	Global DVS logic pins which references a look-up table to allow complete DVS control.
DVS1_0, DVS1_1	DVS input logic pins for Buck1.
DVS2_0, DVS2_1	DVS input logic pins for Buck2.
ADC_IN0, ADC_IN1	Input pins for auxiliary ADC.

2. Specifications

2.1 Absolute Maximum Ratings

Parameter	Minimum	Maximum	Unit
PVIN and AVIN Pins to PGND	-0.3	+6	V
VOUT Pin BUCKx_VOUTFBDIV = 0x0	-0.3	+2.0	V
VOUT Pin BUCKx_VOUTFBDIV = 0x1	-0.3	+2.4	V
VOUT Pin BUCKx_VOUTFBDIV = 0x2	-0.3	+3.0	V
PH to PGND	-0.3	+0.3 + PVIN	V
VIO, EN Pins to GND	-0.3	+0.3 + AVIN	V
RTN, GND to PGND Pins	-0.3	+0.3	V
INT, WDOG_RST, MPIO, GPIO pins to GND	-0.3	+0.3 + VIO	V
ESD Ratings (Note 5)		Value	Unit
Human Body Model (Tested per JS-001-2014)		2	kV
Charged Device Model (Tested per JS-002-2014)		750	V
Latch-Up (Tested per JESD78E; Class 2, Level A)		100	mA

Note:

5. ESD ratings apply to external pins only.

CAUTION: Do not operate at or near the maximum ratings listed for extended periods of time. Exposure to such conditions can adversely impact product reliability and result in failures not covered by warranty.

2.2 Thermal Information

Thermal Resistance (Typical)	θ_{JA} (°C/W)	θ_{JC} (°C/W)
54 Ball WLCSP Package (Notes 6, 7)	42	0.5

Notes:

6. θ_{JA} is measured in free air with the component mounted on a high-effective thermal conductivity test board with "direct attach" features. See [TB379](#).

7. For θ_{JC} , the "case temp" location is taken at the package top center.

Parameter	Minimum	Maximum	Unit
Maximum Junction Temperature (T_J)		+150	°C
Storage Temperature Range (T_S)	-65	+150	°C
Pb-Free Reflow Profile	see TB493		

2.3 Recommended Operation Conditions

Parameter	Minimum	Maximum	Unit
Ambient Operating Temperature Range (T_A)	-40	+85	°C
Operating Junction Temperature (T_J)	-40	+125	°C
Supply Voltage			
AVIN to GND	2.5	5.5	V
PVIN to PGND	2.5	5.5	V
VIO Voltage (VIO to GND)	1.7	AVIN	V
INT, WDOG_RST, MPIO, GPIO Pins to GND	0	VIO	V

2.4 Analog Specifications

AVIN/PVIN = 3.7V, V_{OUT} = 1V, L = 220nH, Frequency = 4MHz, V_{IO} = 1.8V, T_A = +25°C. **Boldface limits apply across the ambient operating temperature range, -40°C to +85°C unless otherwise noted.**

Parameter	Symbol	Test Conditions	Min (Note 8)	Typ	Max (Note 8)	Unit	
Input Supply							
Supply Voltage	AVIN		2.5		5.5	V	
Supply Voltage	PVIN		2.5		5.5	V	
AVIN Supply Current	I _Q	EN = 0V		0.1	1	μA	
AVIN + PVIN Supply Current		EN = 0V		<1	6	μA	
AVIN + PVIN Supply Current EN = AVIN = PVINx = 3.7V		BUCK1_EN[0] = 0x0 and BUCK2_EN[0] = 0x0			22		μA
		4+0 OTP configuration, not switching BUCK1_EN[0] = 0x1 DCM operation BUCK2_EN[0] = 0x0			75		μA
		4+0 OTP configuration, not switching BUCK1_EN[0] = 0x1 1PH CCM operation BUCK2_EN[0] = 0x0			635		μA
		4+0 OTP configuration, not switching BUCK1_EN[0] = 0x1 4PH CCM operation BUCK2_EN[0] = 0x0			765		μA
		2+2 OTP configuration, not switching BUCK1_EN[0] = 0x0 BUCK2_EN[0] = 0x1 DCM operation			85		μA
		2+2 OTP configuration, not switching BUCK1_EN[0] = 0x0 BUCK2_EN[0] = 0x1 1PH CCM operation			485		μA
		2+2 OTP configuration, not switching BUCK1_EN[0] = 0x0 BUCK2_EN[0] = 0x1 2PH CCM operation			560		μA
UVLO Rising Threshold	V _{UVLOR}	Rising	2.52	2.60	2.67	V	
UVLO Falling Threshold	V _{UVLOF}	Falling	2.28	2.34	2.40	V	
Buck Regulation							
Buck Output Voltage Range (Each Output)	V _{OUT}	BUCKx_VOUTFBDIV[1:0] = 0x00	0.300		1.2	V	
		BUCKx_VOUTFBDIV[1:0] = 0x01	0.375		1.5	V	
		BUCKx_VOUTFBDIV[1:0] = 0x02	0.500		2.0	V	
Output Voltage Step Size	V _{STEP}	10-bit control, BUCKx_VOUTFBDIV[1:0] = 0x00		1.2		mV	
		10-bit control, BUCKx_VOUTFBDIV[1:0] = 0x01		1.5		mV	
		10-bit control, BUCKx_VOUTFBDIV[1:0] = 0x02		2.0		mV	
Output Voltage Accuracy (Note 9)	V _{ACC}	CCM, V _{OUT} > 0.6V	-0.3		0.3	%	
		CCM, V _{OUT} > 0.6V T _A = -10°C to +85°C	-0.7		0.7	%	
		CCM, V _{OUT} < 0.6V	-4		4	mV	
		CCM, V _{OUT} < 0.6V T _A = -10°C to +85°C	-5.5		5.5	mV	
Current Matching	I _{MATCH}	I _{OUT} = 5A per phase		10		%	
Dynamic Response							
Dynamic Voltage Scaling (Output Slew Rate)	V _{DVS}	2.5V < V _{IN} < 5.5V: 3mV/μs	-15		15	%	

AVIN/PVIN = 3.7V, V_{OUT} = 1V, L = 220nH, Frequency = 4MHz, V_{IO} = 1.8V, T_A = +25°C. **Boldface limits apply across the ambient operating temperature range, -40°C to +85°C unless otherwise noted. (Continued)**

Parameter	Symbol	Test Conditions	Min (Note 8)	Typ	Max (Note 8)	Unit
Boot-Up Time	V _{BT}	Delay from when PVIN, AVIN, and EN are asserted to when the first Buck's reference starts ramping. This time includes internal reference startup, OTP load, and buck controller calibration time. BUCKx_EN_DELAY = 0x00		1.4		ms
Frequency						
CCM Frequency Tolerance	f _{SW_TOL}	4MHz	-15		15	%
Power Stage						
Buck Output Current (Each Phase)		2.5V < V _{IN} < 5.5V			5	A
High-Side Switch ON-Resistance	HS r _{DS(ON)}	Conditions: PVIN = 3.7V, current = 300mA		23		mΩ
Low-Side Switch ON-Resistance	LS r _{DS(ON)}	Conditions: PVIN = 3.7V, current = 300mA		9		mΩ
Protection						
HSD Current Limit (WOC)	I _{LIMIT}	2.5V < V _{IN} < 5.5V Phase count = 2 or more; WOC = 11.35A	-10		10	%
		2.5V < V _{IN} < 5.5V Phase count = 1; WOC = 8.38A	-10		10	
Thermal Shutdown Accuracy	T _{SPS}	2.5V < V _{IN} < 5.5V, factory default = +140°C	-10		10	%
Thermal Shutdown Hysteresis	T _{SPS_HYS}	2.5V < V _{IN} < 5.5V, factory default = +60°C	-10		10	%
Thermal Warning Alert	T _{ALERT}	2.5V < V _{IN} < 5.5V, factory default = +85°C	-10		10	%
Thermal Warning Hysteresis	T _{ALERT_HYS}	2.5V < V _{IN} < 5.5V, factory default = +12°C	-10		10	%
Output OVP Threshold Accuracy	V _{OVP}	Threshold: +250mV	-35		35	mV
Output UVP Threshold Accuracy	V _{UVP}	Threshold: -250mV	-35		35	mV
ADC						
Output Current Sense Offset	I _{SENSE_OFFSET}		-75		75	mA
Output Current Sense Accuracy	I _{SENSE_ADC}	I _{LOAD} = 500mA (minus offset)	-10		10	%
		3.0V < V _{IN} < 5.0V I _{LOAD} = 500mA (minus offset)	-15		15	%
MPIO/GPIO Operating Conditions						
Allowable Range of Supply for Operation	V _{IO}		1.70	1.80	AVIN	V
Chip Enable Logic Threshold Level						
Low-Level Input Voltage	V _{IL}				0.5	V
High-Level Input Voltage	V _{IH}		1.35			V
Serial Interfaces						
I ² C Frequency Capability	f _{I2C}				3.4	MHz
SPI Frequency Capability	f _{SPI}			26		MHz
MPIO/GPIO Logic Threshold Levels						
Low Level Input Voltage	V _{IL}				0.25 x VIO	V
High Level Input Voltage	V _{IH}		0.75 x VIO			V

AVIN/PVIN = 3.7V, V_{OUT} = 1V, L = 220nH, Frequency = 4MHz, V_{IO} = 1.8V, T_A = +25°C. **Boldface limits apply across the ambient operating temperature range, -40°C to +85°C unless otherwise noted. (Continued)**

Parameter	Symbol	Test Conditions	Min (Note 8)	Typ	Max (Note 8)	Unit
Hysteresis on Input	V _{HYS}		0.1 x V_{IO}			V
Low Level Output	V _{OL}	1mA			0.4	V
High Level Output	V _{OH}	1mA (250μA for 20% drive configuration)	V_{IO} - 0.4			V

Notes:

8. Compliance to datasheet limits is assured by one or more methods: production test, characterization, and/or design.
9. V_{OUT} feedback divider ratio equals 1 (BUCKx_VOUTFBDIV[1:0] = 0x00).
10. As per ["Thermal Information" on page 11](#), operating beyond thermal limits can cause permanent damage.

3. Output Configurations

Table 4. Output Configurations

Output Configuration	Power Stage Assignment	Diagram
4-Phase Connect VOUT2 and RTN2 to PGND Plane	4-Phase: Buck #1 (VOUT1) • Ph1: PH_A • Ph2: PH_B • Ph3: PH_D • Ph4: PH_C	<p style="text-align: center;">4+0 Configuration</p>

Table 4. Output Configurations (Continued)

Output Configuration	Power Stage Assignment	Diagram
<p>3-Phase + 1-Phase</p>	<p>3+1 Configuration:</p> <ul style="list-style-type: none"> 3-phase: Buck #1 (VOUT1) Ph1: PH_A Ph2: PH_B Ph3: PH_D 1-phase: Buck #2 (VOUT2) Ph1: PH_C 	<p>3+1 Configuration</p>

Table 4. Output Configurations (Continued)

Output Configuration	Power Stage Assignment	Diagram
2-Phase + 2-Phase	2+2 Configuration <ul style="list-style-type: none"> • 2-phase: Buck #1 (VOUT1) Ph1: PH_A Ph2: PH_B • 2-phase: Buck #2 (VOUT2) Ph1: PH_C Ph2: PH_D 	<p style="text-align: center;">2+2 Configuration</p>

4. Typical Operating Performance

Unless otherwise noted, operating conditions are: $V_{IN} = 3.8V$, $V_{OUT} = 1.1V$, V_{IO} and $Enable = 1.8V$, $T_A = +25^\circ C$, $f_{SW} = 4MHz$, 2-phase operation, $L = 220nH$, $C_{OUT} = 5 \times 22\mu F + 8 \times 4.3\mu F$.

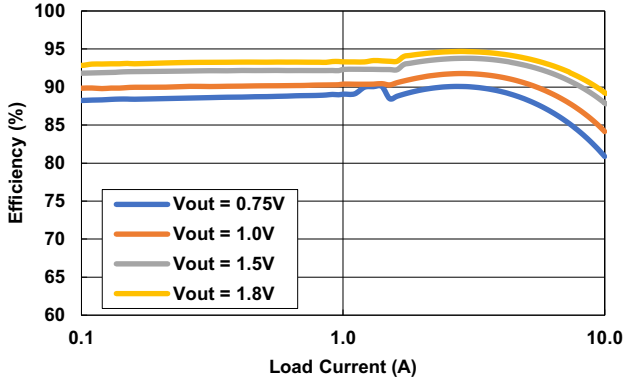

Figure 6. 2-Phase Configuration Efficiency ($V_{IN} = 3.3V$, $f_{SW} = 2MHz$)

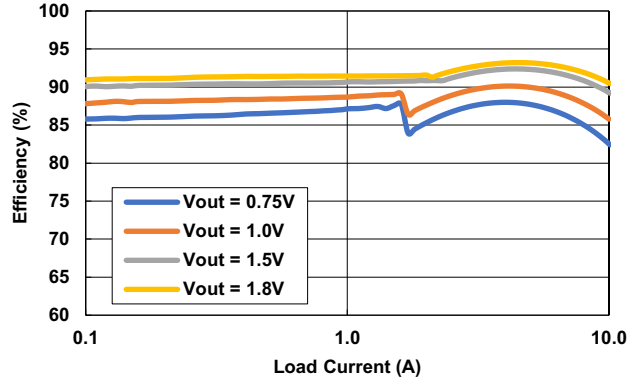

Figure 7. 2-Phase Configuration Efficiency ($V_{IN} = 5.0V$, $f_{SW} = 2MHz$)

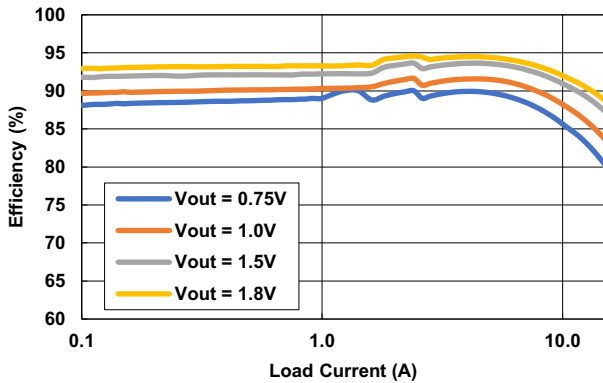

Figure 8. 3-Phase Configuration Efficiency ($V_{IN} = 3.3V$, $f_{SW} = 2MHz$)

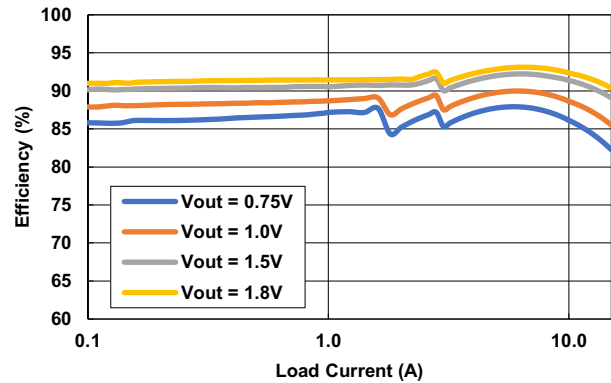

Figure 9. 3-Phase Configuration Efficiency ($V_{IN} = 5.0V$, $f_{SW} = 2MHz$)

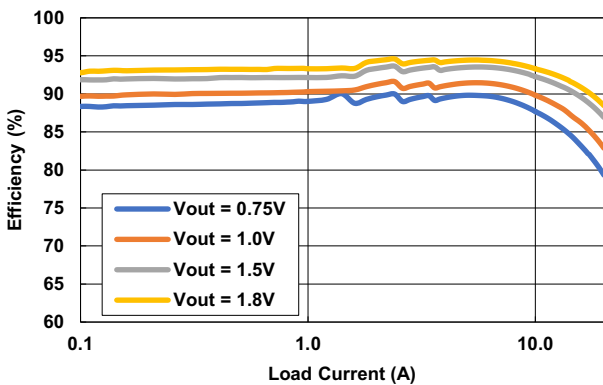

Figure 10. 4-Phase Configuration Efficiency ($V_{IN} = 3.3V$, $f_{SW} = 2MHz$)

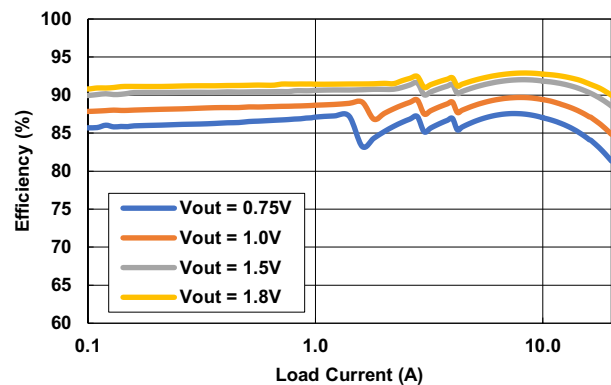

Figure 11. 4-Phase Configuration Efficiency ($V_{IN} = 5.0V$, $f_{SW} = 2MHz$)

Unless otherwise noted, operating conditions are: $V_{IN} = 3.8V$, $V_{OUT} = 1.1V$, V_{IO} and $Enable = 1.8V$, $T_A = +25^\circ C$, $f_{SW} = 4MHz$, 2-phase operation, $L = 220nH$, $C_{OUT} = 5 \times 22\mu F + 8 \times 4.3\mu F$. **(Continued)**

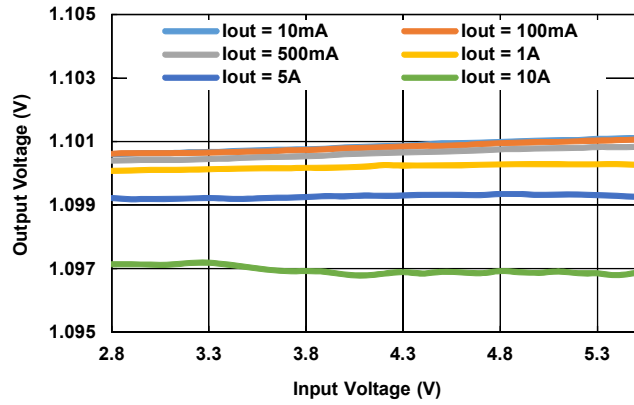

Figure 12. 2-Phase V_{OUT} vs V_{IN} (10mA to 10A)

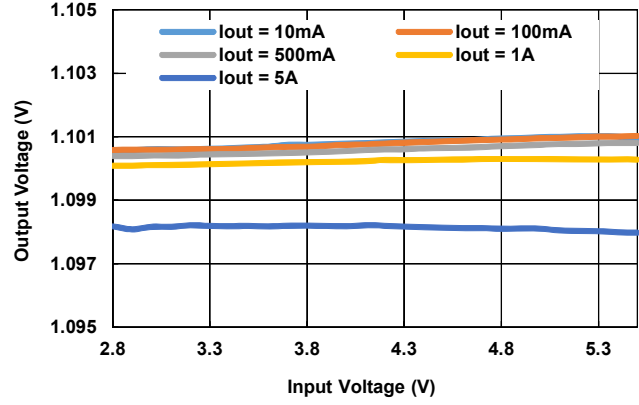

Figure 13. Single-Phase V_{OUT} vs V_{IN} (10mA to 5A)

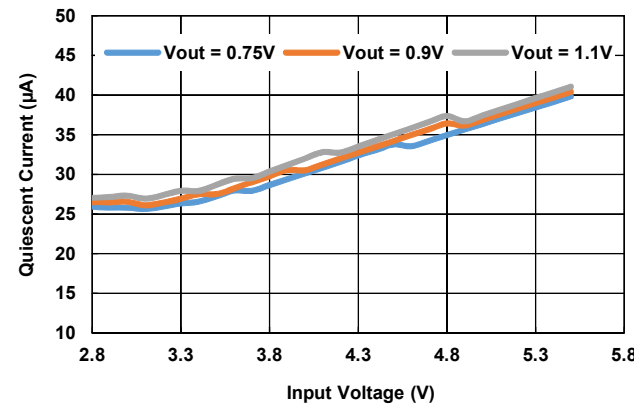

Figure 14. PVIN Quiescent Current (PFM Mode)

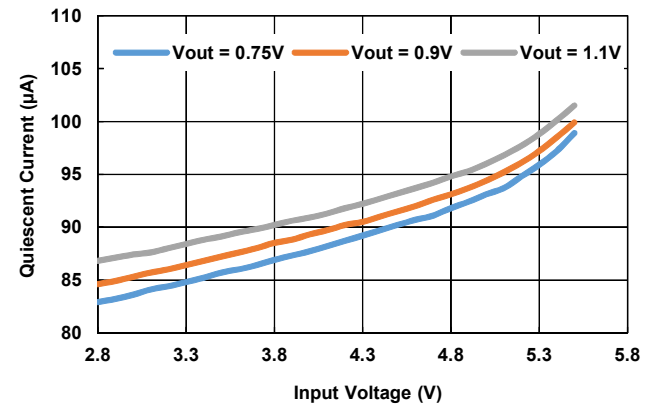

Figure 15. PVIN Quiescent Current (PWM Mode)

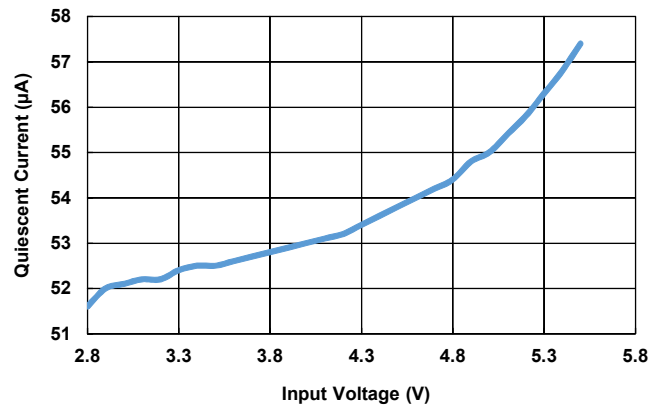

Figure 16. PVIN Quiescent Current (No Switching)

Unless otherwise noted, operating conditions are: $V_{IN} = 3.8V$, $V_{OUT} = 1.1V$, V_{IO} and $Enable = 1.8V$, $T_A = +25^\circ C$, $f_{SW} = 4MHz$, 2-phase operation, $L = 220nH$, $C_{OUT} = 5 \times 22\mu F + 8 \times 4.3\mu F$. **(Continued)**

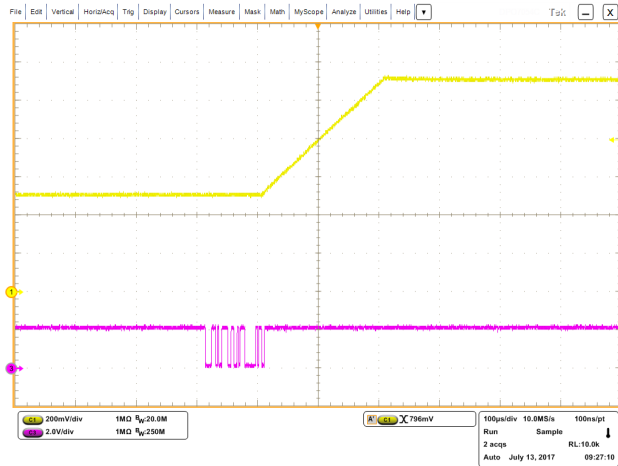

Figure 17. 0.5V to 1.1V DVS; Load = 5A, Slew Rate = 3mV/µs

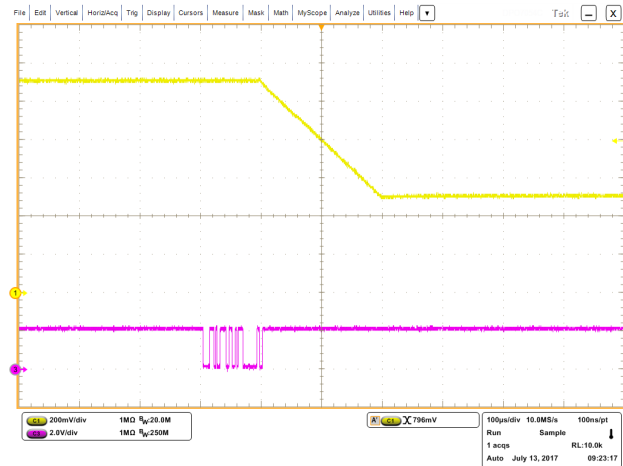

Figure 18. 1.1V to 0.5V DVS; Load = 5A, Slew Rate = 3mV/µs

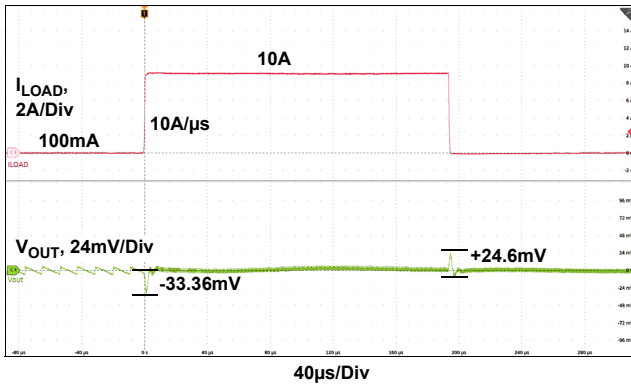

Figure 19. Dual-Phase Transient, $C_{OUT} = 9 \times 22\mu F$ and $L = 220nH/Phase$

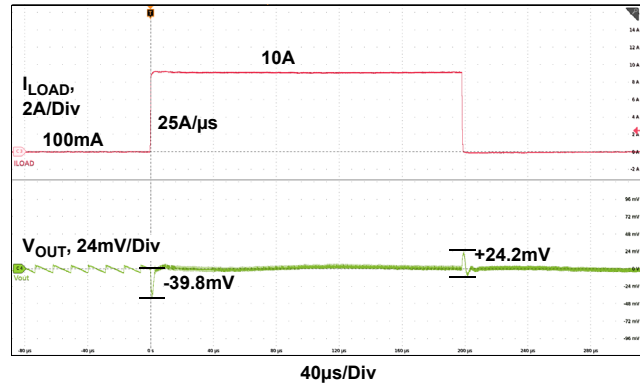

Figure 20. Dual-Phase Transient, $C_{OUT} = 9 \times 22\mu F$ and $L = 220nH/Phase$

5. Applications Information

5.1 Inductor Selection

The ISL91302B is a high efficiency, high performance, dual output multiphase/single-phase synchronous buck converter that can deliver up to 5A of continuous current per phase at 0.3V to 2.0V regulated voltage from a single Li-Ion battery to power portable and handheld devices. The ISL91302B is designed to provide one or two output voltage rails with operational modes setup to 4+0, 3+1, and 2+2 at a nominal switching frequency of 2MHz~4MHz. Contact [support](#) for questions relating to switching frequency of 6MHz. Switching MOSFETs are fully integrated and no additional external MOSFETs or diodes are needed. Each phase requires an equal external inductor that can deliver the maximum load current divided by the number of phases used.

Table 5. Recommended Output Inductors

Manufacturer	Part Number	L x W x H (mm)	Value (nH)	DCR mΩ (Typ)	I _{SAT} (Typ)
Cyntec	HMLB25201T	2.5x2.0x1.0	220	9.4	7.0
Taiyo Yuden	MAKK2520HR22M	2.5x2.0x1.0	220	16	8.5
Cyntec	HTTN2016T	2.0x1.6x1.0	220	13	7.2
Murata	DFE2016E	2.0x1.6x1.0	240	16	7.0
Murata	DFE252012F	2.5x2.0x1.2	470	23	6.7

5.2 Output Capacitor Selection

Output capacitors are needed to provide filtering of square voltage at the phase node into a regulated output voltage. The amount of output capacitance required is based on the parameters of the maximum load step, the slew rate of the load step, and the maximum allowable voltage regulation tolerance during the transient. The amount of ripple voltage at the output capacitor is also a design constraint; the total peak-to-peak ripple voltages produced from the output capacitor is equal to its ESR multiplied by the worst case inductor ripple current.

Make sure to select X7R or X5R type capacitors and consider for DC bias effects. A wide range of output capacitor values can be used.

Table 6. Recommended Output Capacitors

Manufacturer	Part Number	Case Size	Value (μF)	Voltage Rating (V)
TDK	C1608X5R1A226M080AC	0603	22	10
TDK	C0510X6S0G105M030AC	0204	1	4
Murata	LLD154R60G435ME01	0402	4.3	4
Murata	LLL1U4R60G435ME22	0204	4.3	4

5.3 Input Capacitor Selection

Ceramic input capacitors source the AC component of the input current flowing into the high-side MOSFETs. Place them as close to the IC as possible. If long wires are used to bring power to the IC, use additional bulk capacitors between C_{IN} and the battery/power supply to dampen ringing and overshoot at startup.

Internal analog reference circuits also require additional filtering at the AVIN_FLTR pin. A 10 μ F local decoupling capacitor is recommended for each phase on PVIN.

Table 7. Recommended Input Capacitors

Manufacturer	Part Number	Case Size	Value (μ F)	Volt (V)	Input
TDK Corp	CGB2A1X5R1A105M033BC	0402	1	10	AVIN
Kemet	C0402C104K8RACTU	0402	0.1	10	AVIN
Samsung	CL05A10MP5NUNC	0402	10	10	PVIN
Murata	GRM188R61A106MAAL	0603	10	10	PVIN

5.4 ADC Telemetry

The device features a 12-bit (effective) SAR ADC telemetry function that supports internal silicon temperature, individual phase current, total buck output current, output voltage, and input voltage measurements. Two additional channels provide additional internal or external monitoring. Using these channels requires OTP programming from the factory. The ADC is OTP programmed to be turned off during Discontinuous Conduction mode to save current and improve light-load efficiency. The ADC supports two operating modes: Continuous Mode, and Non-continuous (or Single-shot or One-shot) Mode.

The telemetry uses a 16-bit output data format (S13.2). It consists of 1-bit sign and 15-bit data. The two LSB bits represent fractional data (after the decimal point). Reading the ADC output is accomplished by reading the respective MSB (8-bit) and LSB (8-bit). [Table 8](#) shows the registers that hold the ADC data. See [“Register Description by Address” on page 42](#) for more information.

Table 8. ADC Register Addresses

ADC Channel	Register Name	Register Address (hex): ADC MSB Data	Register Address (hex): ADC LSB Data
Temperature	ADC_SAMPLE0MSB/LSB	0x16	0x17
Buck1 Ph1 Current	ADC_SAMPLE1PH1MSB/LSB	0x18	0x19
Buck1 Ph2 Current	ADC_SAMPLE1PH2MSB/LSB	0x1A	0x1B
Buck1 Ph3 Current	ADC_SAMPLE1PH3MSB/LSB	0x1C	0x1D
Buck1 Ph4 Current	ADC_SAMPLE1PH4MSB/LSB	0x1E	0x1F
Buck1 Total Current	ADC_SAMPLE1TMSB/LSB	0x20	0x21
PVIN for Buck1	ADC_SAMPLE2MSB/LSB	0x22	0x23
V_{OUT1}	ADC_SAMPLE3MSB/LSB	0x24	0x25
Buck2 Ph1 Current	ADC_SAMPLE4PH1MSB/LSB	0x26	0x27
Buck2 Ph2 Current	ADC_SAMPLE4PH2MSB/LSB	0x28	0x29
Buck2 Total Current	ADC_SAMPLE4TMSB/LSB	0x2A	0x2B
PVIN for Buck2	ADC_SAMPLE5MSB/LSB	0x2C	0x2D
V_{OUT2}	ADC_SAMPLE6MSB/LSB	0x2E	0x2F
AUX INPUT0	ADC_AUX0MSB/LSB	0x30	0x31
AUX INPUT1	ADC_AUX1MSB/LSB	0x32	0x33

The ADC 16-bit output data LSB is 0.25 when referring to temperature, voltage, or individual phase current. The total buck current measurement has an LSB of 1. See [Table 9](#).

Each channel is filtered through an internally programmable infinite impulse response (IIR) filter. AUX input 0 and AUX input 1 allow you to read the external values with the ISL91302B ADC. Setting the IIR coefficient of a channel to 1 provides no filtering, whereas the 1/128 setting provides the most filtering. The IIR filter coefficient should be set to 1 (code 0x0) in one-shot mode of operation.

Contact [support](#) for questions relating to the ADC.

Table 9. ADC Result Mapping

16-bit ADC Data (hex)	Phase Current (mA)	Total Buck Output Current (mA)	Die Temperature (°C)	Buck Output Voltage (mV)
0x0000	0	0	0	0
0x0001	0.25	1	0.25	0.25
0x0002	0.5	2	0.5	0.5
0x0003	0.75	3	0.75	0.75
0x0004	1	4	1	1
...
0x0010	4	16	4	4
...
0x0100	64	256	64	64
...
0x7FFF	8191.75	32767	8191.75	8191.75
0x8000	-8192	-32768	-8192	-8192
0x8001	-8191.75	-32767	-8191.75	-8191.75
...
0xFFFF	-0.25	-1	-0.25	-0.25

5.5 Dynamic Voltage Scaling (DVS)

The ISL91302B has several options to achieve DVS. Each buck controller has four independently programmable voltage settings to set the output voltage. The settings are DVS0, DVS1, DVS2, and DVS3. Changing the selected DVS number selects the corresponding output voltage. The two methods to select the DVS are:

Method 1) - Use internal registers to select DVS by writing to the BUCKx_DVSSELECT[1:0] bits in the BUCKx_DVSSEL register for each respective buck using SPI or I²C.

To use this method, the BUCKx_DVSCTRL[0] bit has to be set to 0x0 for the corresponding buck. The BUCKxDVSSELECT[1:0] setting allows the user to switch between the four different DVS settings, each of which corresponds to a set of DVS registers holding the DVS information.

For example, DVS0 corresponds to BUCKx_DVS0VOUT92[7:0] and BUCKx_DVS0VOUT10[1:0]. The two register values combined represent the complete 10-bit DAC code for DVS0.

Table 10. DVS Method Selection

BUCKx_DVSCTRL[0]	
0x0	Use BUCKx_DVSSELECT[1:0] to select active DVS configuration
0x1	Use DVS pin(s) to control DVS selection

Table 11. DVS Pointers

BUCKx_DVSSELECT[1:0]	Active DVS for BUCKx
0x0	DVS0

Table 11. DVS Pointers

BUCKx_DVSSELECT[1:0]	Active DVS for BUCKx
0x1	DVS1
0x2	DVS2
0x3	DVS3

Each output voltage is set writing a 10-bit word to DVS Configuration 1 (BUCKx_DVS0CFG1 register) and DVS Configuration 0 (BUCKx_DVS0CFG0 register) in each buck. Configuration 1 holds the eight most significant bits and Configuration 0 holds the last two bits of the 10-bit word. The output voltage does not change until the LSB register has been written.

[Equation 1](#) relates the DVS word and V_{OUT} target.

$$V_{OUT} = \frac{1.234V}{FBDIV} \times \frac{DAC_CODE}{1024} \quad (EQ. 1)$$

DAC_CODE: 0 ~ 1023d; FBDIV(selection): 1, 0.8, or 0.6

In the application, the 10-bit DVS word should be set to ensure the buck output voltage target is always 0.3V or above.

Method 2) - Using GPIO/MPIO pins to achieve DVS, there are five variations depending on the IO_PINMODE register setting. See [Table 2](#).

NOTE: To use DVS by GPIO/MPIO pins requires IO_PINMODE to be OTP programmed before a start-up boot sequence is initiated. On-the-fly programming is not recommended for the following configurations.

(i) **IO_PINMODE = 0x3**: SPI with two Independent Buck DVS pins

MPIO0	MPIO1	MPIO2	MPIO3	GPIO0	GPIO1
SCK	SS_B	MOSI	MISO	DVS1_0	DVS2_0

BUCKx_DVSCTRL[0] should be OTP programmed high before the start-up sequence. The active DVS follows the DVSx_0 pin logic for the respective buck. See [Table 12](#) for more information.

Table 12. Single DVS Pin Logic

Function	
DVS1_0	Active DVS for BUCK1
0	DVS0
1	DVS1
DVS2_0	Active DVS for BUCK2
0	DVS0
1	DVS1

(ii) **IO_PINMODE = 0x4**: I²C with Global DVS and PGOOD pins

MPIO0	MPIO1	MPIO2	MPIO3	GPIO0	GPIO1
DVS_PIN1	DVS_PIN0	PGOOD1	PGOOD2	SCL	SDA

BUCKx_DVSPIN_CTRL[1:0] bits in BUCKx_DVSCFG register in combination with the DVS_PIN1 and DVS_PIN2 sets the active DVS for the respective BUCK. See [Table 13](#) for more information.

BUCKx_DVSCTRL[0] should be OTP programmed high before the start-up sequence.

Table 13. Global DVS Pin Logic

BUCKx_DVSPIN_CTRL[1:0]	DVS_PIN1	DVS_PIN0	Active DVS
0x0	X	X	DVS0
0x1	X	0	DVS0
	X	1	DVS1
0x2	0	X	DVS0
	1	X	DVS2
0x3	0	0	DVS0
	0	1	DVS1
	1	0	DVS2
	1	1	DVS3

Note: The 'X' indicates that either a 0 or 1 is acceptable.

(iii) **IO_PINMODE = 0x5:** I²C with 2 DVS pins for Buck1 and 2 DVS pins for Buck2

MPIO0	MPIO1	MPIO2	MPIO3	GPIO0	GPIO1
DVS1_0	DVS1_1	DVS2_0	DVS2_1	SCL	SDA

The active DVS is selected based off the combined DVSx_1 and DVSx_2 input pin logic. See [Table 14](#) for more information. BUCKx_DVSCTRL[0] should be OTP programmed high before the start-up sequence.

Table 14. Active DVS for 2 DVS Pins Configuration

DVSx_1	DVSx_0	Active DVS for BUCKx
0	0	DVS0
0	1	DVS1
1	0	DVS2
1	1	DVS3

(iv) **IO_PINMODE = 0x6:** I²C with 2 DVS pins and 2 PGOOD pins

MPIO0	MPIO1	MPIO2	MPIO3	GPIO0	GPIO1
DVS1_0	DVS2_0	PGOOD1	PGOOD2	SCL	SDA

BUCKx_DVSCTRL[0] should be OTP programmed high before the start-up sequence. DVS1_0 and DVS2_0 follows the same active DVS table as in IO_PINMODE = 0x3. See [Table 12](#) for more information.

(v) **IO_PINMODE = 0xE:** I2C with 2 DVS pins and 2 AUX ADC pins

MPIO0	MPIO1	MPIO2	MPIO3	GPIO0	GPIO1
ADC_IN0	ADC_IN1	DVS_PIN1	DVS_PIN2	SCL	SDA

DVS_PIN0 and DVS_PIN1 behave the same as in IO_PINMODE = 0x4. See [Table 13](#) for more information. BUCKx_DVSCTRL[0] should be OTP programmed high before the start-up sequence.

5.6 Configuring DVS Speed

5.6.1 Power-Up and Shutdown Slew Rate Setting

The BUCK_x_RSPUP[2:0] bits in the BUCK_x_RSPCFG0 register set the slew rates (DVS speed) in BUCK_x only during V_{OUTx} power-up. Similarly, the BUCK_x_RSPDN[2:0] in the BUCK_x_RSPCFG0 register sets the slew rates in BUCK_x during normal V_{OUTx} shutdown. The achievable slew rates varies with different FB DIV settings (factory OTP programmed). For more details, see Register [BUCK1_RSPCFG0](#).

5.6.2 DVS Transition Slew Rate Setting

BUCK_x_RSPUP[2:0] and BUCK_x_RSPDN[2:0] in the BUCK_x_RSPCFG1 register sets the slew rates (DVS speed) in BUCK_x during normal DVS transition. The achievable slew rates varies with different FB DIV settings (factory OTP programmed). For more details, see Register [BUCK1_RSPCFG1](#).

5.7 Output Voltage Setting

Each output voltage is set by writing a 10-bit word to DVS Configuration 1 (BUCK_x_DVS0CFG1 register) and DVS Configuration 0 (BUCK_x_DVS0CFG0 register) in each buck. Configuration 1 holds the MSB and Configuration 0 holds the last two bits of the 10-bit word. The output voltage does not change until the LSB register has been written. [BUCK1_DVS0CFG1](#) shows the relationship between the DVS word and V_{OUT}.

5.8 Power Sequencing

When the master chip Enable (EN) pin is brought above an NMOS threshold, the ISL91302B powers up its key biasing circuits, loads the OTP configuration registers, and does one of two things based on the preprogrammed OTP setting:

(1) Manual buck start-up:

Program the internal IO_BUCK_x_EN bits to 1 from I²C/SPI to enable the respective buck. When IO_PINMODE = 0x1, the EN_A and EN_B pins can also be used to enable the respective bucks. If using IO_PINMODE = 0x1, the internal IO_BUCK_x_EN bits should be set high in OTP. The slew rate of each buck during its soft-start is specified by the BUCK_x_RSPUP[2:0] bits.

Note: The programmable (1ms to 63ms) delay using BUCK_x_EN_DLY[5:0] is not used for Manual Buck start-up.

(2) Auto Buck start-up from master chip enable pin:

Run a predetermined start-up sequence for the buck outputs as soon as BOOT is complete. The slew rate of each buck during its soft-start is specified in BUCK_x_RSPUP[2:0].

Note: The delay, BUCK_x_EN_DLY[5:0] shown in [Figure 21](#) as EN_dlyx, is programmable from 0 to 63ms in 1ms steps.

[Figure 21](#) provides an example of power-up configurability. The master chip enable pin (EN) transitions from 0 to 1 and OTP is loaded over 1.4ms. After the initial 1.4ms boot interval, the buck output start-up sequence begins. In the [Figure 21](#) example, BUCK1_EN_DLY is set for 0ms and BUCK2_EN_DLY is set for 1ms.

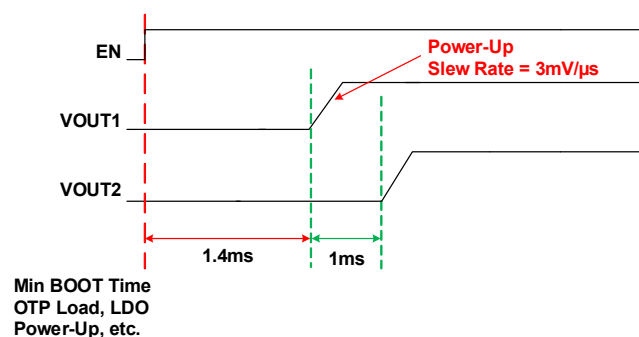

Figure 21. Master Chip Enable Power-Up Example

The buck outputs can also be programmed to execute a controlled shutdown in two ways:

(1) **Manual buck power-down:**

Program the internal IO_BUCKx_EN bit to 0 through I²C/SPI or lower the Buck Enable pin (EN_A or EN_B when IO_PINMODE = 0x1). The manual method can be used to power down a specific buck (with a controlled slew rate) while keeping the rest of the chip alive.

Note: The programmable (0ms to 63ms) delay from BUCKx_SHUTDOWN_DLY[5:0] is not used for manual buck power-down.

(2) **Auto Buck power-down from master chip enable pin:**

When the master chip Enable pin (EN) is brought below the falling threshold of the comparator, the Bucks are ramped down at a controlled rate using preprogrammed delays. This is then followed by the power-down of the bias circuits forcing the chip into shutdown. The slew rate of each buck during its power-down (down to ~250mV) is specified in BUCKx_RSPPDN[2:0].

Note: The delay, BUCKx_SHUTDOWN_DLY[5:0] shown in [Figure 22](#) as Dis_dlyx, is programmable from 0 to 63ms in 1ms steps.

[Figure 22](#) provides an example of power-down configurability. The master chip enable pin (EN) transitions from logic 1 to 0. In the [Figure 22](#) example, BUCK1_SHUTDOWN_DLY is set for 1ms and BUCK2_SHUTDOWN_DLY is set for 2ms.

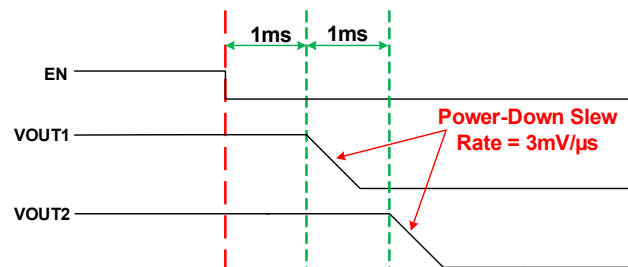

Figure 22. Auto Chip Power-Down Example

The actual slew rate that each buck ramps down to is specified by the register BUCKx_RSPSHUTDOWN. This slew rate is controlled until the output voltage is ~250mV, at which point the ISL91302B engages a weak resistive pull-down (if enabled by factory OTP) that can keep $V_{OUT} = 0V$ when the buck is not enabled. [Figure 23](#) shows an example of the weak pull-down behavior.

• **Option 1:** If the disable event for a buck output is the master chip enable pin (EN) falling below its logic low threshold, then when the output falls below 250mV, the output voltage decay is dictated by the system load passively discharging the buck output capacitance. PULL_DOWN_DISCHARGE IO_MPIO_DATA[4] bit per the IO_MPIO_DATA register is **not** used in this method.

• **Option 2:** If the disable event for a buck output is the master chip enable pin (EN) remaining high and the enable register bit (IO_BUCKx_EN) transitioning from a logic 1 to a logic 0, then PULL_DOWN_DISCHARGE IO_MPIO_DATA[4] bit per the IO_MPIO_DATA register is used enabling an internal weak pull down.

Note: The weak pull-down can be disabled (using factory OTP).

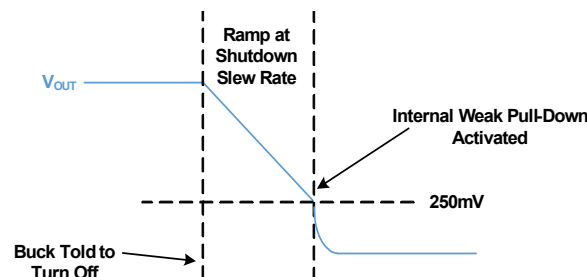

Figure 23. Buck Disable Waveform

5.9 Watchdog Time (WDOG_RST Pin)

The ISL91302B implements a watchdog function that allows the output voltages to return to a safe default when communication to the processor host is lost. If the WDOG_RST pin goes into the failure state for a duration greater than the programmed debounce time, the default voltages from OTP are restored.

The IO_RSTDVS_CTRL[1:0] bits select which buck(s) respond to the WDOG_RST pin. The polarity of the WDOG_RST pin is active low.

Table 15. WDOG_RST Function

Action	
At Boot Up	DVS registers are loaded with values stored in OTP.
After Debounce Time	Restore selected output voltages to their original values stored in OTP (DVS0), and slew the buck outputs to that voltage.

The total recovery time for the buck is the sum of t_{SLEW} and $t_{DEBOUNCE}$. The target voltage WDOG_RST pin resets the ISL91302B buck output(s), set by DVS0, that are in the BUCKx_DVS0CFG1 and BUCKx_DVS0CFG0 registers.

t_{SLEW} is determined by BUCKx_RSPUP[2:0] and BUCKx_RSPDN[2:0]. $t_{DEBOUNCE}$ is factory programmable.

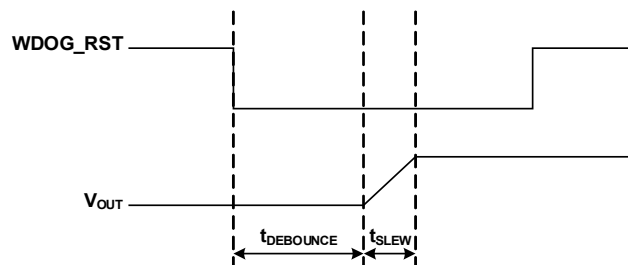

Figure 24. Watchdog Timer Example Case

5.10 Interrupt Pin

The ISL91302B can alert the host when a warning or a fault has occurred through an IRQ interrupt request signal with configurable masking options that is connected to a configurable interrupt (INT) pin. The interrupt pin can be programmed to be active high, active low, an open drain, or a CMOS output.

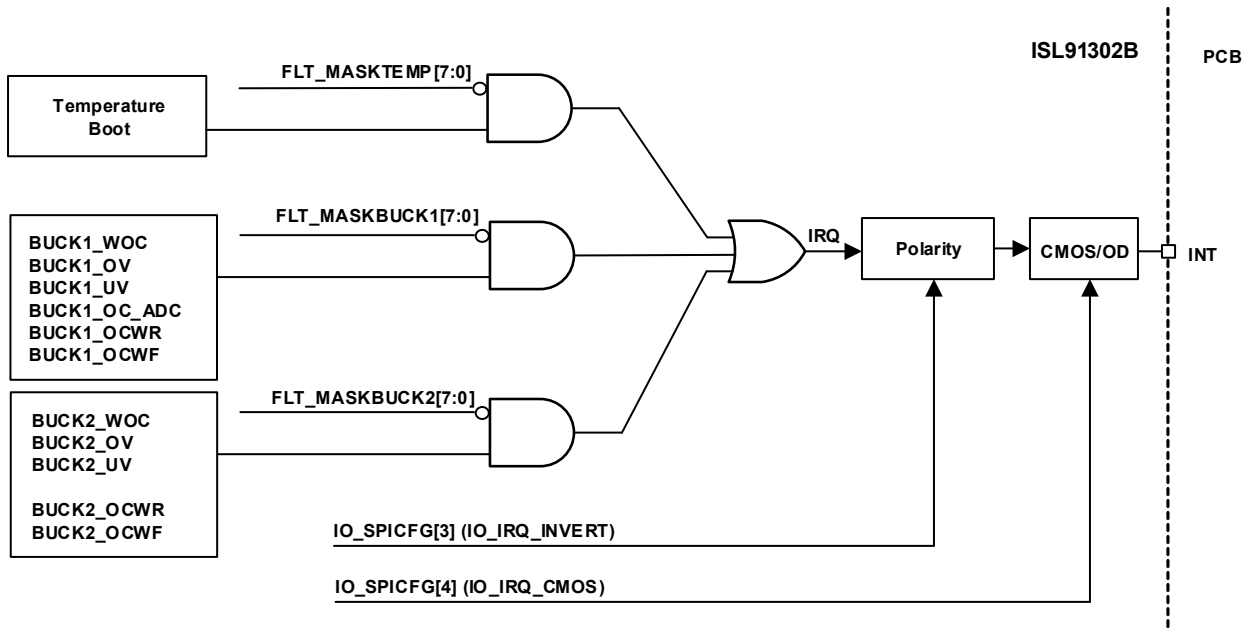

Figure 25. Interrupt Tree

5.11 Decay Mode

When the output voltage is programmed to a lower value than the present voltage, you can use Decay mode to reduce the output voltage only at the rate that the output load it is pulling down. This can improve efficiency when lowering the voltage at a controlled rate is not necessary. BUCKx_DVS0DECAY can be programmed to enable or disable Decay mode.

6. Protection Features (Faults)

The ISL91302B has integrated Overcurrent (OC), Overvoltage (OV), Undervoltage (UV), and Over-Temperature (OT) protection features.

6.1 Over-Temperature Protection

The ISL91302B provides protection against over-temperature conditions. An over-temperature protection circuit continuously monitors the die temperature of the chip and raises a fault when the temperature exceeds a predefined limit programmed by Register “[FLT_TEMP SHUTDN](#)”. The ISL91302B also contains a programmable thermal warning threshold set by Register “[FLT_TEMP WARN](#)”. Programmable Hysteresis enables the circuit to clear the fault or warning once the temperature is below a user-defined safe temperature. The warning and shutdown hysteresis level are factory programmable. Contact Renesas [support](#) for custom settings. The over-temperature protection is disabled if all bucks are operating in PFM mode or in the off state.

6.2 Overcurrent Protection Mode

The ISL91302B has a comparator-based OCP and an ADC-based OCP mechanism. The comparator based OCP or ‘WOC’ block has a current comparator that compares the load current through the high-side power FET with the reference current level through a replica device. If the sensed FET current is higher than the WOC threshold, the WOC is triggered immediately, preventing a catastrophic condition. The WOC disables the buck and latches the power-stage into tri-state until the fault is cleared. The WOC fault is self-cleared when the OC condition is removed. The buck attempts to re-enable in a “hiccup” type fashion. The ADC-based OCP monitors the averaged high-side and low-side MOSFET current for each phase and is slower but more accurate than the comparator-based WOC. If the Buck total current is higher than the ADC based OCP threshold, the ADC OCP is triggered, which shuts down the Buck and latches the power-stage into tri-state. ADC-based OCP can be cleared only by recycling the PVIN/AVIN or by toggling the EN pin. Note that the ADC-based OC cannot be cleared by toggling the IO_BUCKx_EN bit by I²C/SPI.

Overcurrent protection can be enabled or disabled using the fault register setting in FLT_BUCKx_CTRL. ADC-based current warning limits can be adjusted with the FLT_BUCKx_ISENSEWARN register. ADC-based current shutdown limits can be adjusted with the FLT_BUCKx_ISENSESHUTDN register.

6.3 Overvoltage (OV)/Undervoltage (UV) Protection

The OV/UV protection circuitry has low power comparators configured with differential input and single-ended outputs capable of working over large common-mode input ranges. This comparator monitors the output voltage in both DCM and CCM for faults. By default, when an OV/UV event is triggered, the buck converter is shut down until the fault is cleared. Fault control register FLT_BUCKx_CTRL enables or disables the functionality. The OV/UV limits are adjustable using the BUCKx_UVOVTH[1:0] bits in the BUCKx_PROTCFG register. See [Table 16](#) for more details.

Table 16. OV/UV Protection Thresholds

BUCKxUVOVTH[1:0]	OV/UV Threshold
0x0	±150mV around DAC target
0x1	±200mV around DAC target
0x2	±250mV around DAC target
0x3	±300mV around DAC target

7. Serial Communication Interface

The ISL91302B has two serial interface protocols to read/write the registers.

- SPI
- I²C

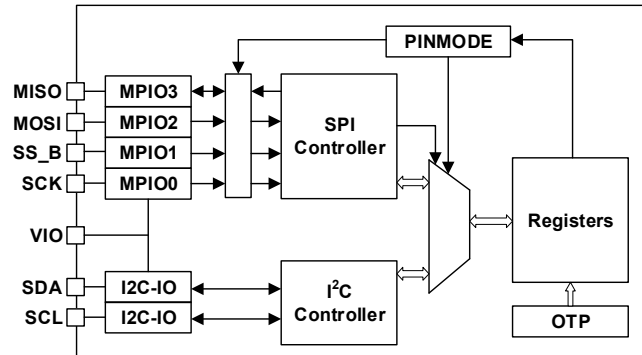

Figure 26. SPI and I²C Interface Block Diagram

The arbitration of the register access bus between SPI and I²C is determined by the pad MPIO1 when using IO_PINMODE = 0x0, as shown in [Table 17](#):

Table 17. SPI/I²C Register Access

Register IO_PINMODE	Pad MPIO_1 (SS_B)	Register Access
0	0	SPI (read/write access (Note 11))
	1	I ² C (Note 12)

Notes:

11. When the device is configured for SPI access, the I²C should not be addressed with the device ID.
12. When the device is configured for I²C access in PINMODE 0, the SS_B line must be held high.

After switching from SPI to I²C or vice versa, a minimum of 50ns wait time is required before starting a transaction.

7.1 SPI Serial Interface

The SPI interface is a general specification 4-wire slave interface capable of operating at a clock speed of up to 26MHz. It is based on byte transfers. The ISL91302B does not support SPI reads on the MISO bus when using multiple slave devices on the same bus.

7.1.1 SPI Data Protocol

Both Read and Write SPI transactions begin when SS_B goes low and end when SS_B goes high.

7.1.1.1 Write Operation

To write to the ISL91302B, the master (controller) needs to drive SS_B low, then send the Control Byte followed by the register address, packet length (if IO_SPI MODE = 1), and data bytes to be written. The controller drives SS_B high to terminate the transaction as shown in [Figure 27](#).

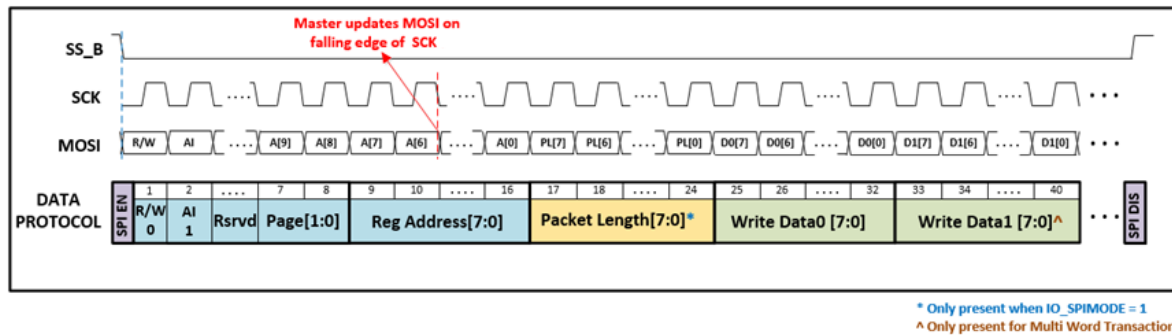

Figure 27. SPI Write Transaction with IO_SPIMODE = 1; IO_SPICPOL = 0; IO_SPICPHA = 0

The MSB of the Control byte is the R/W bit, which needs to be set to ‘write’ operation (see [“IO_SPIRWPOL” on page 52](#)). Bit 6, AI indicates whether the operation is a single-byte write a multi-byte write. Bits 1 and 0 of the Control byte indicate the page number of the register location to be written (MSBs of the register address). The register address byte is the 8-bit address of the register within the page specified by the Page[1:0] bits. If IO_SPIMODE = 1, the register address needs to be followed by an 8-bit packet length that indicates the number of bytes to be written. After the packet length field, the master needs to send the data bytes. When all eight bits of data are received, they are written to the specified register address and the ISL91302B increments the register address.

In single byte transactions, (AI = 0 or Packet length = 1), the ISL91302B goes into the wait state and waits for SS_B to go high.

In multi-byte transactions with IO_SPIMODE = 1, the ISL91302B writes the subsequently received data bytes to sequentially incrementing addresses until the number of bytes, as specified by ‘packet length’, are received, then goes into the wait state and waits for SS_B to go high. For multi-byte transactions with IO_SPIMODE = 0 and AI = 1, the ISL91302B keeps writing the subsequently received data bytes to sequentially incrementing addresses until SS_B goes high. If SS_B goes high in the middle of a transaction, the transaction is terminated. The data byte is written if all eight bits are received.

7.1.1.2 Read Operation

To read from the ISL91302B, the master (controller) needs to drive SS_B low then send the Control Byte followed by the register address and packet length (if IO_SPIMODE = 1). The ISL91302B then sends the data bytes from the requested registers. Finally, the master drives SS_B high to terminate the transaction. The MSB of the Control byte is the R/W bit, which needs to be set to ‘read’ operation (see [“IO_SPIRWPOL” on page 52](#)). Bit 6, whether the operation is a single-byte read or a multi-byte read. Bits 1 and 0 of the Control byte indicate the page number of the register location be read (MSBs of the register address). The register address byte is the 8-bit address of the register within the page specified by the Page[1:0] bits. If IO_SPIMODE = 1, the register address needs to be followed by an 8-bit packet length that indicates the number of bytes to be written. Following the packet length field, the ISL91302B will send the data from the requested register. When all eight bits of data from the requested register address are sent, the ISL91302B increments the register address.

In a single-byte transaction, (AI = 0 or Packet length = 1), the ISL91302B goes into a wait state and waits for SS_B to go high.

In a multi-byte transaction with IO_SPIMODE = 1, the ISL91302B sends the data bytes from sequentially incrementing addresses until the number of bytes as specified by ‘packet length’ are sent and then goes into a wait state and waits for SS_B to go high. For multi-byte transactions with IO_SPIMODE = 0 and AI = 1, the ISL91302B keeps sending data bytes from sequentially incrementing addresses until SS_B goes high.

Note: The MISO pin is pulled low while SS_B is high.

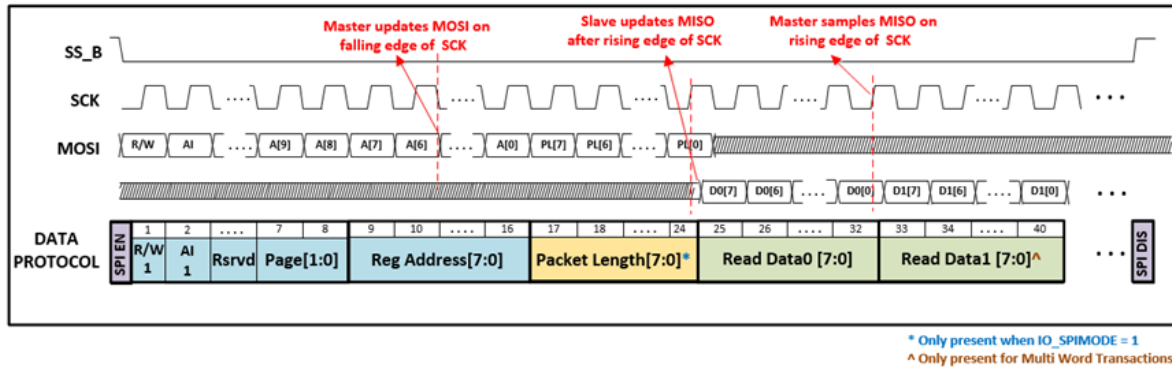

Figure 28. SPI Read Transaction with IO_SPIMODE = 1; IO_SPICPOL = 0; IO_SPICPHA = 0

R/W	Read/Write Bit Indicating Read or Write Operation
AI	Auto Increment. 1 indicates a multi-byte transfer, 0 indicates a single byte transfer
Page	2-bit page address of the register to be written or read
Address	8-bit register address of the register to be written or read
Packet Length	8-bit packet length indicating number of data bytes to be transferred. Overrides AI when IO_SPIMODE = 1
Read Data	Data in the register at Address [7:0] + n
Write Data	Data to be written to the register at Address [7:0] + n

7.1.2 SPI Configuration

The following register bits configure the SPI operation:

- **IO_SPICPOL**: SPI clock polarity, ISL91302B is configured as active high, IO_SPICPOL = 0
- **IO_SPICPHA**: SPI clock phase, ISL91302B samples data on rising edge of SPI clock, IO_SPICPHA = 0

The four possible clocking modes are shown in [Figure 29](#).

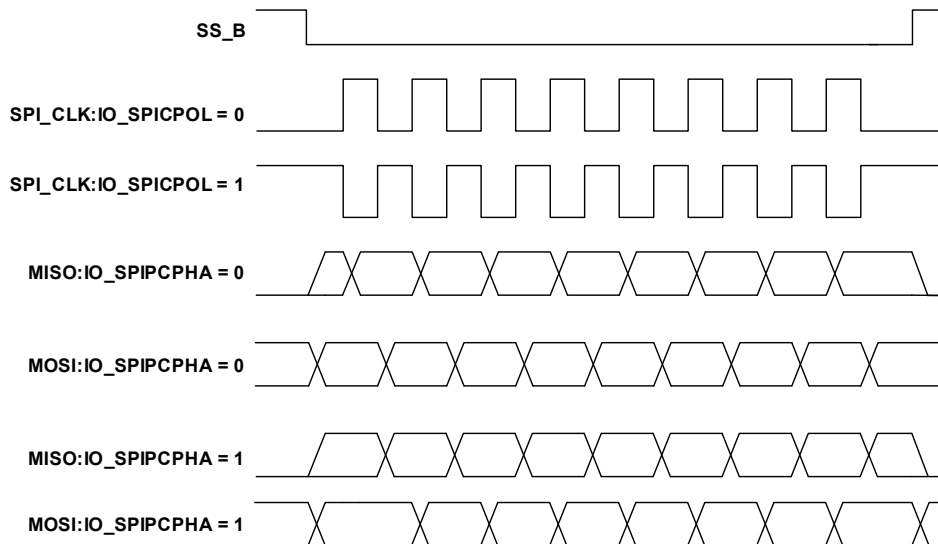

Figure 29. Four Possible Clocking Modes

- **IO_SPIWPOL**: R/W bit polarity, ISL91302B SPI_RWPOL is set to 0. 1 = Read, 0 = Write

SPI_RWPOL	R/W	Operation
0	0	Write
0	1	Read

- **IO_SPIMODE**: Packet length enable. The ISL91302B uses packet length mode by default, meaning the third data byte from master is the packet length and indicates the total number of data words to be sent or received in a burst transaction

7.1.3 SPI Timing

Figure 30 on page 34 shows SPI timing for IO_SPICPOL = 0; IO_SPICPHA = 0. The timing values in Table 18 on page 34 hold true for other values of IO_SPICPOL, IO_SPICPHA as well.

Table 18. Timing Values

Parameter	Symbol	Min	Max	Units
Clock Period	t_1	38.4		ns
Enable Lead Time	t_2	12		ns
Enable Lag Time	t_3	12		ns
Clock High or Low Time	t_4	15		ns
Data Setup Time (Input)	t_5	12		ns
Data Hold Time (Input)	t_6	10		ns
Time MISO is Stable before the Next Rising Edge of CLK	t_7	5		ns
Data Held after Clock Edge (Output)	t_8	5		ns
Load Capacitance	C_L		10	pF

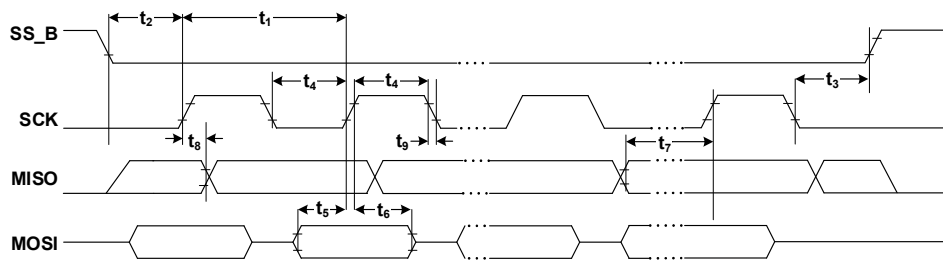

Figure 30. SPI Timing for IO_SPICPHA = 0, IO_SPICPOL = 0

7.2 I²C Interface

The I²C interface is a simple bidirectional 2-wire bus protocol that consists of the Serial Clock Control (SCL) and the Serial Data Signal (SDA). The ISL91302B hosts a slave I²C interface that supports data speeds up to 3.4Mbps. SCL is an input to the ISL91302B and is supplied by the controller. SDA is bidirectional. The ISL91302B has an open-drain output to transmit data on SDA. An external pull-up resistor must be placed on the serial data line to pull the drain output high during data transmission.

The ISL91302B uses a 7-bit hardware address scheme. The default address is set to 0x1D by a one-time programmable fuse.

7.2.1 I²C Bus Operation

The chip supports 7-bit addressing. The ISL91302B I²C device address is reconfigurable through the OTP.

All communication over the I²C interface is conducted by sending the MSB of each byte of data first. Data states on the SDA line can change only during SCL LOW periods. SDA state changes during SCL HIGH are reserved for indicating START and STOP conditions (see [Figure 35 on page 36](#)).

All I²C interface operations must begin with a START condition, which is a HIGH to LOW transition of SDA while SCL is HIGH. The ISL91302B continuously monitors the SDA and SCL lines for the START condition and does not respond to any command until this condition is met. All I²C interface operations must be terminated by a STOP condition, which is a LOW to HIGH transition of SDA while SCL is HIGH.

An Acknowledge (or ACK), is a software convention that indicates a successful data transfer. The transmitting device, either master or slave, releases the SDA bus after transmitting eight bits. During the ninth clock cycle, the receiver pulls the SDA line LOW to acknowledge the reception of the eight bits of data ([Figure 35 on page 36](#)). The ISL91302B responds with an ACK after recognizing a START condition, followed by a valid Identification Byte (also known as I²C Address). The ISL91302B also responds with an ACK after receiving a Data Byte of a write operation. The master must respond with an ACK after receiving a Data Byte of a read operation.

7.2.1.1 Write Operation

A Write operation requires a START condition, followed by an ISL91302B I²C Address byte with the R/W bit set to 0, a Register Address Byte, Data Bytes, and a STOP condition. After each byte, the ISL91302B responds with an ACK. After every data byte, the ISL91302B auto increments the register address so subsequent data bytes get written to sequentially incremental register locations. A STOP condition that terminates the write operation must be sent by the master after sending at least one full data byte and its associated ACK signal. If a STOP byte is issued in the middle of a data byte, the write is not performed.

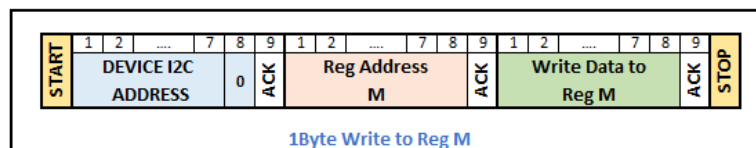

Figure 31. 1-Byte Write to Register M

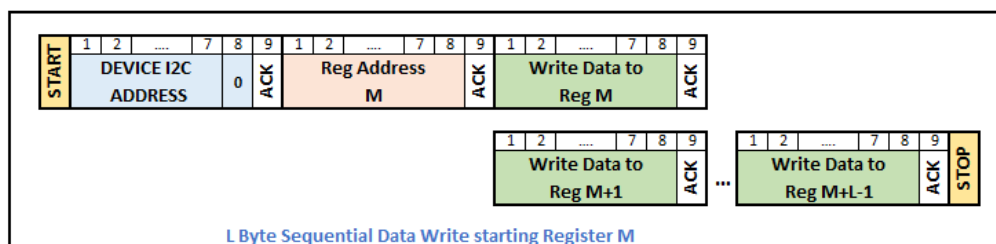

Figure 32. L-Byte Sequential Data Write Starting Register M

7.2.1.2 Read Operation

A Read operation consists of a three-byte “dummy write” instruction to send the register address to begin reading from, followed by a Current Address Read operation. The master initiates the operation, issuing the following sequence: a START condition, followed by an ISL91302B I²C Address byte with the R/W bit set to “0”, a Register Address Byte, a second START, and a second ISL91302B I²C Address byte with the R/W bit set to “1”. After each of the three bytes, the ISL91302B responds with an ACK. The ISL91302B then transmits Data Bytes. The master terminates the Read operation from the ISL91302B by issuing a STOP condition following the last bit of the last data byte. After every data byte, the ISL91302B auto increments the register address so subsequent data bytes are sent from sequentially incremental register locations.

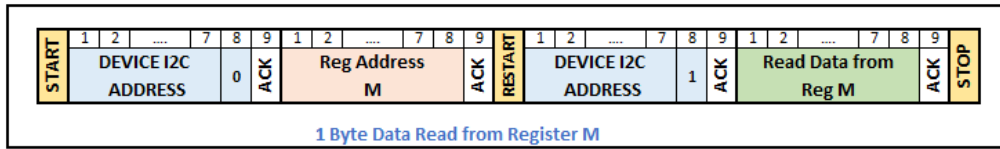

Figure 33. 1-Byte Data Read from Register M

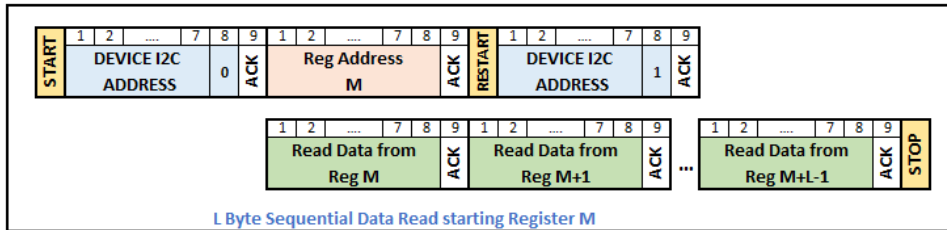

Figure 34. L-Byte Sequential Data Read Starting Register M

7.2.2 I²C Timing

The timing specifications of the I²C I/O from the I²C specification are shown in [Figure 35](#) and [Table 19 on page 37](#). The I²C controller provides a slave I²C transceiver capable of interpreting I²C protocol in Standard, Fast, Fast+, and High Speed modes.

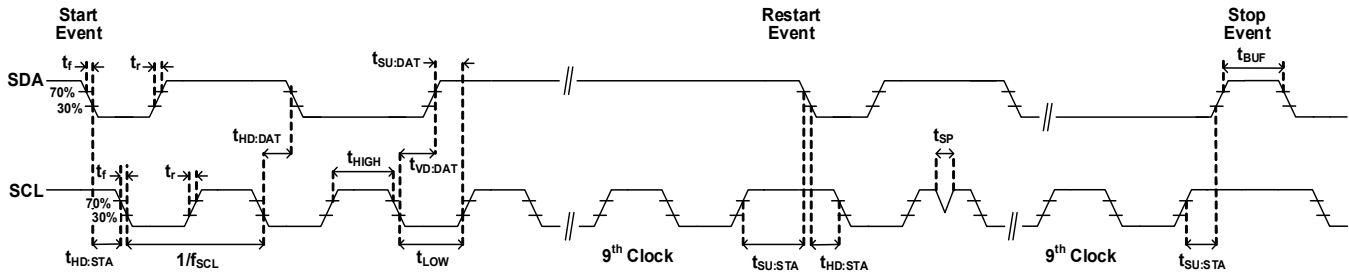

Figure 35. I²C Timing

Table 19. I²C Specification

Parameter	Symbol	Standard Mode		Fast Mode		Fast Mode Plus		High Speed Mode		Unit
		Min	Max	Min	Max	Min	Max	Min	Max	
Clock Frequency	f _{SCL}	0	100	0	400	0	1000	0	3400	kHz
Hold Time (repeated) START Condition (after this period, the first clock pulse is generated)	t _{HD;STA}	4000	-	600	-	260	-	160	-	ns
LOW Period of the SCL Clock	t _{LOW}	4700	-	1300	-	500	-	160	-	ns
HIGH Period of the SCL Clock	t _{HIGH}	4000	-	600	-	260	-	60	-	ns
Setup Time for a Repeated START Condition	t _{SU;STA}	4700	-	600	-	260	-	160	-	ns
Data Hold Time	t _{HD;DAT}	15	-	15	-	15	-	15	70	ns
Data Setup Time	t _{SU;DAT}	250	-	100	-	50	-	10	-	ns
Rise Time of SCL	t _{rCL}	-	1000	-	300	-	120	-	40	ns
Fall Time of SCL	t _{fCL}	-	300	-	300	20 × (V _{DD} /5.5V)-	120	-	40	ns
Rise Time of SDA	t _{rDA}	-	1000	20	300	-	120	10 (Note 14)	80	ns
Fall Time of SDA	t _{fDA}	-	300	20 × (V _{DD} /5.5V) (Note 13)	300	20 × (V _{DD} /5.5V) (Note 13)	120	10 (Note 14)	80	ns
Setup Time for STOP Condition	t _{SU;STO}	4000	-	600	-	260	-	160	-	ns
Bus Free Time between a STOP and START Condition	t _{BUF}	4700	-	1300	-	500	-	-	-	ns
Capacitive Load for each Bus Line	C _b	-	400	-	400	-	400	-	100	pF
Output Fall Time from VIHmin to VILmax	t _{of}	-	250[5]	20 × (V _{DD} /5.5V)[6]	250[5]	20 × (V _{DD} /5.5V)[6]	120[7]	10 (Note 14)	80	ns
Pulse Width of Spikes Suppressed by the Input Filter	t _{SP}	-	-	0	50	0	50	0	10	ns

Notes:

13. Only valid for V_{DD} < 4V.14. Only valid for V_{DD} < 1.9V.15. V_{DD} is the pull-up source to the I²C lines (GPIO0, GPIO1).

8. Board Layout Recommendations

Proper PCB layout is a very important design practice to ensure a satisfactory performance from the ISL91302B high frequency multiphase switching regulator. The power loop consists of the output inductor L, the output capacitor C_{OUT}, the PH pin, and the PGND pin. It is important to make the power loop as small as possible. The connecting traces among them should be direct, short, and wide. The same practice should be applied to the connections of the PVIN pin, the input capacitor, and PGND. The switching node of the converter, the PH pin, and the traces connected to this node are very noisy, so keep the VOUT and RTN lines and other noise sensitive traces away from these traces. Place the input capacitors as close as possible to the PVIN(s) and PGND(s) pins. Connect the ground of the input and output capacitors as close as possible. A solid ground plane is helpful for a good EMI performance.

Inductor placement should be as close to the phase pins as possible. Use wide traces and reduce the length to improve the overall efficiency and reduce the amount of radiated EMI. For the phase traces, Renesas recommends descending one layer to reduce the effective path to the inductor. Match the length and width of each inductor trace and number of microvias to help ensure proper current sharing between phases.

Place an AVIN filter capacitor as close as possible to the AVIN_FILT pin but away from noise sources. Always reference the GND pad of the decoupling capacitor to a quiet GND plane.

Do not use plated through-holes when passing the WLCSP pins to lower layers. If microvias are required to pass down multiple layers, Renesas recommends staggering them.

The VOUT and RTN lines are used to sense the output voltage and should be routed directly to the load. Connecting the RTN line to ground away from the load causes a ground error in the output voltage load regulation due to parasitic ground resistance. Keep these traces away from switching nodes such as converter phase nodes or high-speed digital signals. Use small low inductance capacitors at the load to improve noise immunity and transient response to the ISL91302B.

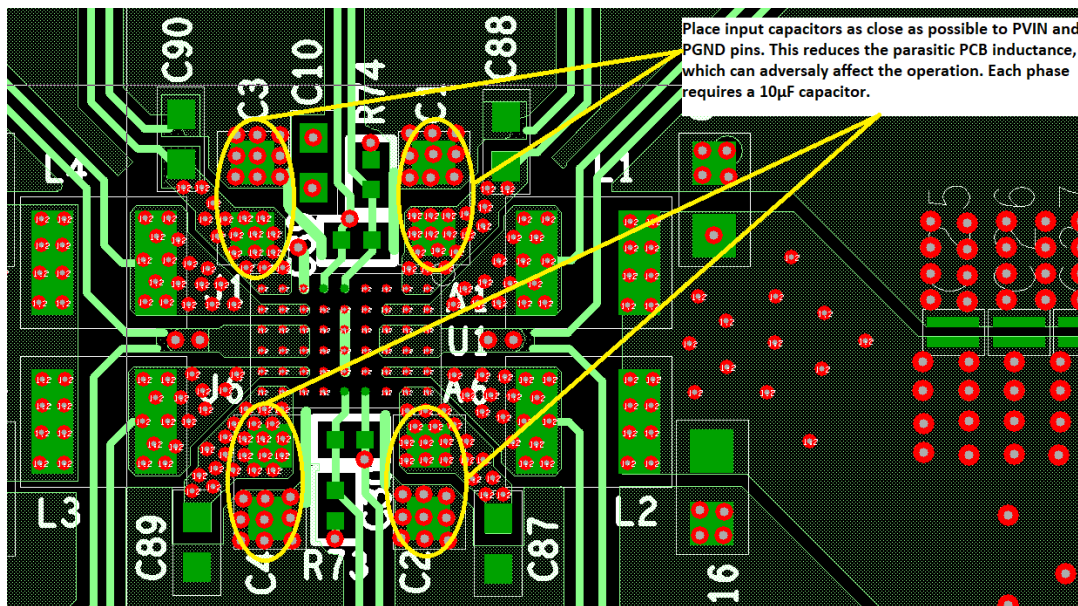

Figure 36. Recommended PCB Layout Top Layer

Provide a solid ground plane in the adjacent layer to provide a low impedance path to support high current flow. Copper planes need to be parallel with the phase traces on the top layer to minimize resistance, and they must be surrounded by a GND plane to prevent noise coupling.

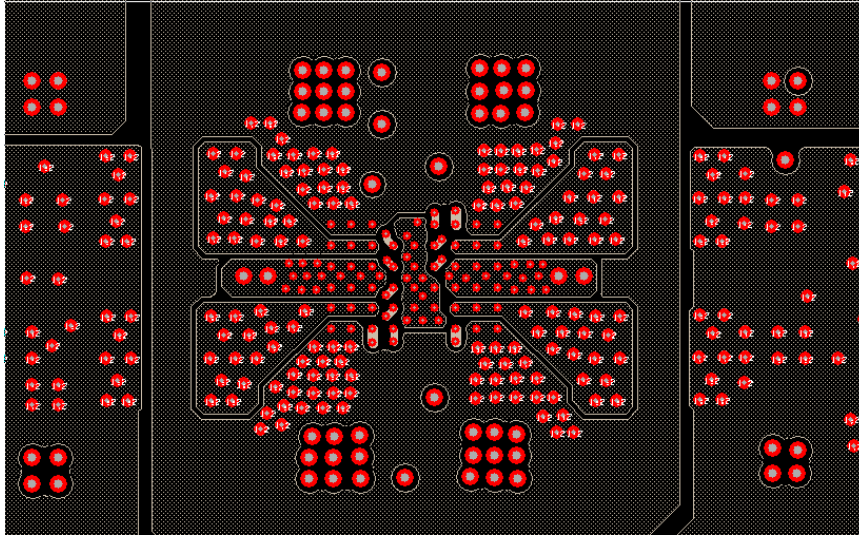

Figure 37. Recommended PCB Layout Second Layer

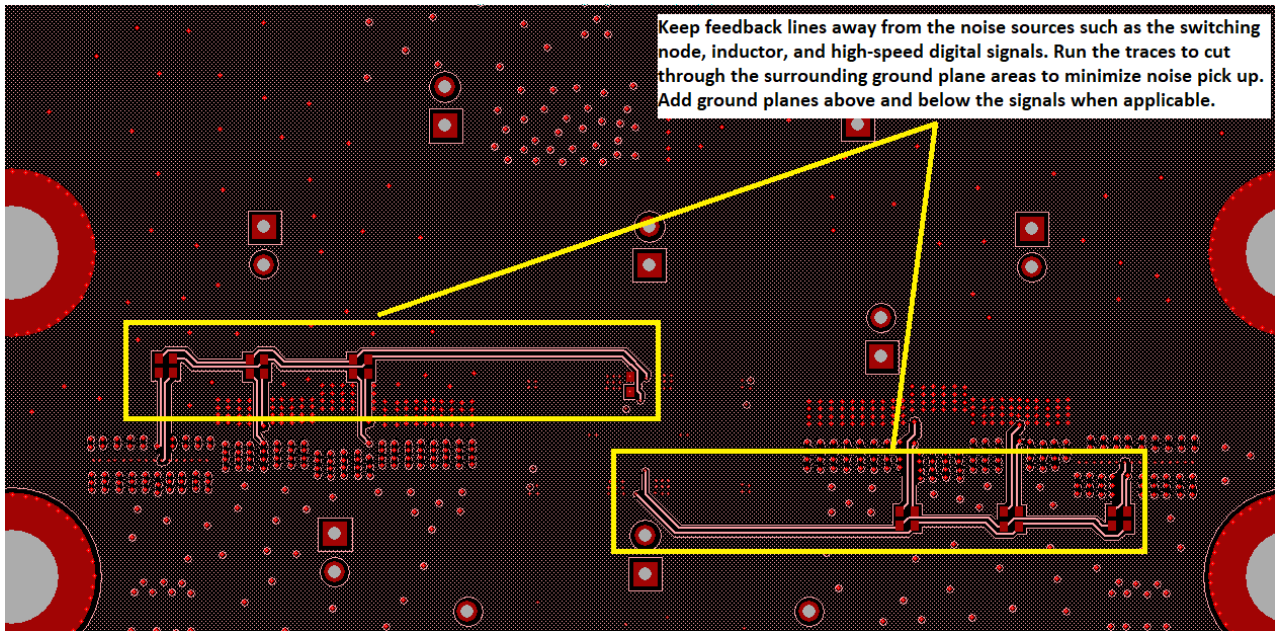

Figure 38. Recommended PCB Layout Bottom Layer

8.1 PCB Layout Summary

- Place input capacitors as close as possible to their respective PVIN and PGND pins
- Route phase nodes with short, wide traces and avoid any sensitive nodes
- Route VOUT and RTN lines differentially to the load and use small low ESL capacitors at the load for bypassing
- Output capacitors should be close to the inductors and have a low impedance path to the PGND pins
- Keep digital and phase nodes from intersecting AVIN_FILT, VOUT, and RTN lines on adjacent layers

8.2 PCB Design for WLCSP Recommendations

Design Feature	Design Specification
Cu Pad Diameter	0.4mm pitch: 0.215 ±0.012mm
Microvia Structure	All microvias should be copper filled.
Microvia Stacking	Avoid microvia stacking if possible. Use staggered vias instead. If microvia stacking is absolutely necessary for the layout, the maximum number of recommended via stacks is two.
Plated Through-Hole (PTH) Location	No PTH should be placed under the CSP bump pads. Microvias and trace routing should be used to fan the PTH away from the CSP bump array.

9. Register Address Map

When communicating with registers that contain reserved bits, Renesas recommends performing a masked write/read to avoid modifying sensitive register values.

Address	Register	Address	Register	Address	Register
0x01	IO_CHIPNAME	0x30	ADC_AUX0MSB	0x74	BUCK1_DVS1CFG1
0x0F	IO_SOFTRESET	0x31	ADC_AUX0LSB	0x75	BUCK1_DVS1CFG0
0x10	CHIPSTATE	0x32	ADC_AUX1MSB	0x76	BUCK1_DVS2CFG1
0x11	CHIPSTATE_DCMGOOD	0x33	ADC_AUX1LSB	0x77	BUCK1_DVS2CFG0
0x13	FLT_RECORDTEMP	0x43	IO_SPICFG	0x78	BUCK1_DVS3CFG1
0x14	FLT_RECORDBUCK1	0x44	IO_MODECTRL	0x79	BUCK1_DVS3CFG0
0x15	FLT_RECORDBUCK2	0x45	IO_RSTDVS	0x7A	BUCK1_VOUTMAXMSB
0x16	ADC_SAMPLE0MSB	0x46	IO_PINMODE	0x7B	BUCK1_VOUTMAXLSB
0x17	ADC_SAMPLE0LSB	0x50	ADC_RATECCMDCM	0x7C	BUCK1_DVSCFG
0x18	ADC_SAMPLE1PH1MSB	0x51	ADC_RATEIDLE	0x7D	BUCK1_DVSSEL
0x19	ADC_SAMPLE1PH1LSB	0x52	ADC_TEMPCFG	0x7E	BUCK1_RSPCFG1
0x1A	ADC_SAMPLE1PH2MSB	0x53	ADC_BUCK1CFG	0x7F	BUCK1_RSPCFG0
0x1B	ADC_SAMPLE1PH2LSB	0x54	ADC_BUCK2CFG	0x80	BUCK1_EN_DLY
0x1C	ADC_SAMPLE1PH3MSB	0x55	ADC_AUXRATECFG	0x81	BUCK1_SHUTDN_DLY
0x1D	ADC_SAMPLE1PH3LSB	0x58	FLT_TEMPWARN	0x82	BUCK2_EA2
0x1E	ADC_SAMPLE1PH4MSB	0x59	FLT_TEMPSHUTDN	0x85	BUCK2_DCM
0x1F	ADC_SAMPLE1PH4LSB	0x5A	FLT_TEMPCHYS	0x86	BUCK2_CFG3
0x20	ADC_SAMPLE1TMSB	0x5B	FLT_BUCK1_ISENSEWARN	0x8A	BUCK2_PROTCFG
0x21	ADC_SAMPLE1TLSB	0x5C	FLT_BUCK2_ISENSEWARN	0x8E	BUCK2_DVS0CFG1
0x22	ADC_SAMPLE2MSB	0x5D	FLT_BUCK1_ISENSESHUTDN	0x8F	BUCK2_DVS0CFG0
0x23	ADC_SAMPLE2LSB	0x5E	FLT_BUCK2_ISENSESHUTDN	0x90	BUCK2_DVS1CFG1
0x24	ADC_SAMPLE3MSB	0x60	FLT_MASKTEMP	0x91	BUCK2_DVS1CFG0
0x25	ADC_SAMPLE3LSB	0x61	FLT_MASKBUCK1	0x92	BUCK2_DVS2CFG1
0x26	ADC_SAMPLE4PH1MSB	0x62	FLT_MASKBUCK2	0x93	BUCK2_DVS2CFG0
0x27	ADC_SAMPLE4PH1LSB	0x63	FLT_OT_CTRL	0x94	BUCK2_DVS3CFG1
0x28	ADC_SAMPLE4PH2MSB	0x64	FLT_BUCK1_CTRL	0x95	BUCK2_DVS3CFG0
0x29	ADC_SAMPLE4PH2LSB	0x65	FLT_BUCK2_CTRL	0x96	BUCK2_VOUTMAXMSB
0x2A	ADC_SAMPLE4TMSB	0x66	BUCK1_EA2	0x97	BUCK2_VOUTMAXLSB
0x2B	ADC_SAMPLE4TLSB	0x69	BUCK1_DCM	0x98	BUCK2_DVSCFG
0x2C	ADC_SAMPLE5MSB	0x6A	BUCK1_CFG3	0x99	BUCK2_DVSSEL
0x2D	ADC_SAMPLE5LSB	0x6E	BUCK1_PROTCFG	0x9A	BUCK2_RSPCFG1
0x2E	ADC_SAMPLE6MSB	0x72	BUCK1_DVS0CFG1	0x9B	BUCK2_RSPCFG0
0x2F	ADC_SAMPLE6LSB	0x73	BUCK1_DVS0CFG0	0x9C	BUCK2_EN_DLY
				0x9D	BUCK2_SHUTDN_DLY

Note: The registers not listed in the register map and RESERVED bits in the register map are reserved for factory use only. Changing these registers/bits can result in unexpected operation.

10. Register Description by Address

Address	Bit	Name	R/W	Default	Description																	
IO_CHIPNAME																						
0x01	7:0	IO_CHIPNAME	R	0x02	<table border="1"> <tr> <td colspan="2">Chip name. Set by Renesas</td> </tr> <tr> <td>0x02</td> <td>ISL91302B, dual/single output PMIC</td> </tr> </table>	Chip name. Set by Renesas		0x02	ISL91302B, dual/single output PMIC													
Chip name. Set by Renesas																						
0x02	ISL91302B, dual/single output PMIC																					
IO_SOFTRESET																						
0x0F	7:1	Reserved	N/A	0x00	Reserved																	
	0	IO_SOFTRESET	R/W	0x0	<table border="1"> <tr> <td colspan="2">Reset all Registers And Reload from OTP</td> </tr> <tr> <td>0x0</td> <td>Do nothing</td> </tr> <tr> <td>0x1</td> <td>Reset all registers and reload from OTP</td> </tr> </table>	Reset all Registers And Reload from OTP		0x0	Do nothing	0x1	Reset all registers and reload from OTP											
Reset all Registers And Reload from OTP																						
0x0	Do nothing																					
0x1	Reset all registers and reload from OTP																					
CHIPSTATE																						
0x10	7	BG_BANDGAPOK	R	0x0	<table border="1"> <tr> <td colspan="2">Bandgap State</td> </tr> <tr> <td>0x0</td> <td>Bandgap outside of range</td> </tr> <tr> <td>0x1</td> <td>Bandgap operating in proper range</td> </tr> </table>	Bandgap State		0x0	Bandgap outside of range	0x1	Bandgap operating in proper range											
	Bandgap State																					
	0x0	Bandgap outside of range																				
	0x1	Bandgap operating in proper range																				
	6	INTLDO_VDDOK	R	0x0	<table border="1"> <tr> <td colspan="2">VDD state (for Both Analog And Digital LDOs and V_{BAT})</td> </tr> <tr> <td>0x0</td> <td>V_{BAT} or Internal 1.5V outside of range</td> </tr> <tr> <td>0x1</td> <td>V_{BAT} and Internal 1.5V LDOs operating properly</td> </tr> </table>	VDD state (for Both Analog And Digital LDOs and V _{BAT})		0x0	V _{BAT} or Internal 1.5V outside of range	0x1	V _{BAT} and Internal 1.5V LDOs operating properly											
VDD state (for Both Analog And Digital LDOs and V _{BAT})																						
0x0	V _{BAT} or Internal 1.5V outside of range																					
0x1	V _{BAT} and Internal 1.5V LDOs operating properly																					
5	Reserved	R	0x0	Reserved																		
4:2	BUCK1_PHASECOUNT	R	0x0	<table border="1"> <tr> <td colspan="2">Number of Active Phases</td> </tr> <tr> <td>0x0</td> <td>Disabled (power-down)</td> </tr> <tr> <td>0x1</td> <td>1</td> </tr> <tr> <td>0x2</td> <td>2</td> </tr> <tr> <td>0x3</td> <td>3</td> </tr> <tr> <td>0x4</td> <td>4</td> </tr> <tr> <td>0x5</td> <td>Reserved</td> </tr> <tr> <td>0x6</td> <td>Reserved</td> </tr> <tr> <td>0x7</td> <td>Reserved</td> </tr> </table>	Number of Active Phases		0x0	Disabled (power-down)	0x1	1	0x2	2	0x3	3	0x4	4	0x5	Reserved	0x6	Reserved	0x7	Reserved
Number of Active Phases																						
0x0	Disabled (power-down)																					
0x1	1																					
0x2	2																					
0x3	3																					
0x4	4																					
0x5	Reserved																					
0x6	Reserved																					
0x7	Reserved																					
1:0	BUCK2_PHASECOUNT	R	0x0	<table border="1"> <tr> <td colspan="2">Number of Active Phases</td> </tr> <tr> <td>0x0</td> <td>Disabled (power-down)</td> </tr> <tr> <td>0x1</td> <td>1</td> </tr> <tr> <td>0x2</td> <td>2</td> </tr> <tr> <td>0x3</td> <td>Reserved</td> </tr> </table>	Number of Active Phases		0x0	Disabled (power-down)	0x1	1	0x2	2	0x3	Reserved								
Number of Active Phases																						
0x0	Disabled (power-down)																					
0x1	1																					
0x2	2																					
0x3	Reserved																					

Address	Bit	Name	R/W	Default	Description						
CHIPSTATE_DCMPCGOOD											
0x11	7:4	Reserved	R	0x0	Reserved						
	3	BUCK1_DCMSTATE	R	0x0	<table border="1"> <tr> <td colspan="2">DCM/CCM State of Buck1</td> </tr> <tr> <td>0x0</td> <td>CCM</td> </tr> <tr> <td>0x1</td> <td>DCM</td> </tr> </table>	DCM/CCM State of Buck1		0x0	CCM	0x1	DCM
	DCM/CCM State of Buck1										
	0x0	CCM									
0x1	DCM										
2	BUCK2_DCMSTATE	R	0x0	<table border="1"> <tr> <td colspan="2">DCM/CCM State of Buck2</td> </tr> <tr> <td>0x0</td> <td>CCM</td> </tr> <tr> <td>0x1</td> <td>DCM</td> </tr> </table>	DCM/CCM State of Buck2		0x0	CCM	0x1	DCM	
DCM/CCM State of Buck2											
0x0	CCM										
0x1	DCM										
1	BUCK1_PGOODSTATE	R	0x0	<table border="1"> <tr> <td colspan="2">Power-Good State for Buck1</td> </tr> <tr> <td>0x0</td> <td>Cleared when Buck1 is disabled or DAC set to 0V when BUCK1_PGOODDAC0V[0] = 0x0</td> </tr> <tr> <td>0x1</td> <td>Power is good (same signal as going to pin). Set after completion of first soft-start (delay controlled by BUCK1_PGOODDELAY[1:0])</td> </tr> </table>	Power-Good State for Buck1		0x0	Cleared when Buck1 is disabled or DAC set to 0V when BUCK1_PGOODDAC0V[0] = 0x0	0x1	Power is good (same signal as going to pin). Set after completion of first soft-start (delay controlled by BUCK1_PGOODDELAY[1:0])	
Power-Good State for Buck1											
0x0	Cleared when Buck1 is disabled or DAC set to 0V when BUCK1_PGOODDAC0V[0] = 0x0										
0x1	Power is good (same signal as going to pin). Set after completion of first soft-start (delay controlled by BUCK1_PGOODDELAY[1:0])										
0	BUCK2_PGOODSTATE	R	0x0	<table border="1"> <tr> <td colspan="2">Power-Good State for Buck2</td> </tr> <tr> <td>0x0</td> <td>Cleared when Buck2 is disabled or DAC set to 0V when BUCK2_PGOODDAC0V[0] = 0x0</td> </tr> <tr> <td>0x1</td> <td>Power is good (same signal as going to pin). Set after completion of first soft-start (delay controlled by BUCK2_PGOODDELAY[1:0])</td> </tr> </table>	Power-Good State for Buck2		0x0	Cleared when Buck2 is disabled or DAC set to 0V when BUCK2_PGOODDAC0V[0] = 0x0	0x1	Power is good (same signal as going to pin). Set after completion of first soft-start (delay controlled by BUCK2_PGOODDELAY[1:0])	
Power-Good State for Buck2											
0x0	Cleared when Buck2 is disabled or DAC set to 0V when BUCK2_PGOODDAC0V[0] = 0x0										
0x1	Power is good (same signal as going to pin). Set after completion of first soft-start (delay controlled by BUCK2_PGOODDELAY[1:0])										

Address	Bit	Name	R/W	Default	Description								
FLT_RECORDTEMP													
0x13	7	FLT_BOOT	R	0x0	<table border="1"> <tr> <td colspan="2">BOOT Occurred</td> </tr> <tr> <td colspan="2">Read only, cleared when read</td> </tr> <tr> <td>0x0</td> <td>No boot process occurred since the last time this register was read</td> </tr> <tr> <td>0x1</td> <td>Boot process occurred (set high after OTP read is finished)</td> </tr> </table>	BOOT Occurred		Read only, cleared when read		0x0	No boot process occurred since the last time this register was read	0x1	Boot process occurred (set high after OTP read is finished)
	BOOT Occurred												
	Read only, cleared when read												
	0x0	No boot process occurred since the last time this register was read											
	0x1	Boot process occurred (set high after OTP read is finished)											
6:4	Reserved	R	0x0	Reserved									
3	FLT_TEMPSDR	R	0x0	<table border="1"> <tr> <td colspan="2">Over-Temperature (OT) Shutdown (Rising Threshold)</td> </tr> <tr> <td colspan="2">Read only, cleared when read</td> </tr> <tr> <td>0x0</td> <td>No fault, less than threshold</td> </tr> <tr> <td>0x1</td> <td>Fault, greater than threshold</td> </tr> </table>	Over-Temperature (OT) Shutdown (Rising Threshold)		Read only, cleared when read		0x0	No fault, less than threshold	0x1	Fault, greater than threshold	
Over-Temperature (OT) Shutdown (Rising Threshold)													
Read only, cleared when read													
0x0	No fault, less than threshold												
0x1	Fault, greater than threshold												
2	FLT_TEMPWARNR	R	0x0	<table border="1"> <tr> <td colspan="2">Over-Temperature (OT) Warning (Rising Threshold)</td> </tr> <tr> <td colspan="2">Read only, cleared when read</td> </tr> <tr> <td>0x0</td> <td>No fault, less than threshold</td> </tr> <tr> <td>0x1</td> <td>Fault, greater than threshold</td> </tr> </table>	Over-Temperature (OT) Warning (Rising Threshold)		Read only, cleared when read		0x0	No fault, less than threshold	0x1	Fault, greater than threshold	
Over-Temperature (OT) Warning (Rising Threshold)													
Read only, cleared when read													
0x0	No fault, less than threshold												
0x1	Fault, greater than threshold												
1	FLT_TEMPWARNF	R	0x0	<table border="1"> <tr> <td colspan="2">Over-Temperature (OT) Warning (Falling Threshold) (Warning1 hysteresis)</td> </tr> <tr> <td colspan="2">Read only, cleared when read</td> </tr> <tr> <td>0x0</td> <td>No fault, less than threshold</td> </tr> <tr> <td>0x1</td> <td>Fault, greater than threshold</td> </tr> </table>	Over-Temperature (OT) Warning (Falling Threshold) (Warning1 hysteresis)		Read only, cleared when read		0x0	No fault, less than threshold	0x1	Fault, greater than threshold	
Over-Temperature (OT) Warning (Falling Threshold) (Warning1 hysteresis)													
Read only, cleared when read													
0x0	No fault, less than threshold												
0x1	Fault, greater than threshold												
0	FLT_TEMPSPDF	R	0x0	<table border="1"> <tr> <td colspan="2">Over-Temperature (OT) Shutdown (Falling Edge) (Shutdown Hysteresis)</td> </tr> <tr> <td colspan="2">Read only, cleared when read</td> </tr> <tr> <td>0x0</td> <td>No fault, less than threshold</td> </tr> <tr> <td>0x1</td> <td>Fault, greater than threshold</td> </tr> </table>	Over-Temperature (OT) Shutdown (Falling Edge) (Shutdown Hysteresis)		Read only, cleared when read		0x0	No fault, less than threshold	0x1	Fault, greater than threshold	
Over-Temperature (OT) Shutdown (Falling Edge) (Shutdown Hysteresis)													
Read only, cleared when read													
0x0	No fault, less than threshold												
0x1	Fault, greater than threshold												

Address	Bit	Name	R/W	Default	Description								
FLT_RECORDBUCK1													
0x14	7	Reserved	R	0x0	Reserved								
	6	FLT_BUCK1_WOC	R	0x0	<table border="1"> <tr> <td colspan="2">Way Overcurrent (WOC) for Buck1</td> </tr> <tr> <td colspan="2">Read only, cleared when read</td> </tr> <tr> <td>0x0</td> <td>No fault, less than threshold</td> </tr> <tr> <td>0x1</td> <td>Fault, greater than threshold</td> </tr> </table>	Way Overcurrent (WOC) for Buck1		Read only, cleared when read		0x0	No fault, less than threshold	0x1	Fault, greater than threshold
	Way Overcurrent (WOC) for Buck1												
	Read only, cleared when read												
	0x0	No fault, less than threshold											
	0x1	Fault, greater than threshold											
	5	FLT_BUCK1_OV	R	0x0	<table border="1"> <tr> <td colspan="2">Overvoltage (OV)</td> </tr> <tr> <td colspan="2">Read only, cleared when read</td> </tr> <tr> <td>0x0</td> <td>No fault, less than threshold</td> </tr> <tr> <td>0x1</td> <td>Fault, greater than threshold</td> </tr> </table>	Overvoltage (OV)		Read only, cleared when read		0x0	No fault, less than threshold	0x1	Fault, greater than threshold
	Overvoltage (OV)												
Read only, cleared when read													
0x0	No fault, less than threshold												
0x1	Fault, greater than threshold												
4	FLT_BUCK1_UV	R	0x0	<table border="1"> <tr> <td colspan="2">Undervoltage (UV)</td> </tr> <tr> <td colspan="2">Read only, cleared when read</td> </tr> <tr> <td>0x0</td> <td>No fault, greater than threshold</td> </tr> <tr> <td>0x1</td> <td>Fault, less than threshold</td> </tr> </table>	Undervoltage (UV)		Read only, cleared when read		0x0	No fault, greater than threshold	0x1	Fault, less than threshold	
Undervoltage (UV)													
Read only, cleared when read													
0x0	No fault, greater than threshold												
0x1	Fault, less than threshold												
3	FLT_BUCK1_OCSDR	R	0x0	<table border="1"> <tr> <td colspan="2">Overcurrent (OC) Shutdown (Rising Threshold) for Buck1</td> </tr> <tr> <td colspan="2">Read only, cleared when read</td> </tr> <tr> <td>0x0</td> <td>No fault, less than threshold</td> </tr> <tr> <td>0x1</td> <td>Fault, greater than threshold</td> </tr> </table>	Overcurrent (OC) Shutdown (Rising Threshold) for Buck1		Read only, cleared when read		0x0	No fault, less than threshold	0x1	Fault, greater than threshold	
Overcurrent (OC) Shutdown (Rising Threshold) for Buck1													
Read only, cleared when read													
0x0	No fault, less than threshold												
0x1	Fault, greater than threshold												
2	FLT_BUCK1_OCWR	R	0x0	<table border="1"> <tr> <td colspan="2">Overcurrent (OC) Warning (Rising Threshold) for Buck1</td> </tr> <tr> <td colspan="2">Read only, cleared when read</td> </tr> <tr> <td>0x0</td> <td>No fault, less then threshold</td> </tr> <tr> <td>0x1</td> <td>Fault, greater than threshold</td> </tr> </table>	Overcurrent (OC) Warning (Rising Threshold) for Buck1		Read only, cleared when read		0x0	No fault, less then threshold	0x1	Fault, greater than threshold	
Overcurrent (OC) Warning (Rising Threshold) for Buck1													
Read only, cleared when read													
0x0	No fault, less then threshold												
0x1	Fault, greater than threshold												
1	FLT_BUCK1_OCWF	R	0x0	<table border="1"> <tr> <td colspan="2">Overcurrent (OC) Warning (Falling Threshold) Buck1</td> </tr> <tr> <td colspan="2">Read only, cleared when read</td> </tr> <tr> <td>0x0</td> <td>No fault, less then threshold</td> </tr> <tr> <td>0x1</td> <td>Fault, greater than threshold</td> </tr> </table>	Overcurrent (OC) Warning (Falling Threshold) Buck1		Read only, cleared when read		0x0	No fault, less then threshold	0x1	Fault, greater than threshold	
Overcurrent (OC) Warning (Falling Threshold) Buck1													
Read only, cleared when read													
0x0	No fault, less then threshold												
0x1	Fault, greater than threshold												
0	Reserved	R	0x0	Reserved									

Address	Bit	Name	R/W	Default	Description																																								
FLT_RECORDBUCK2																																													
0x15	7	Reserved	R	0x0	See " FLT_RECORDBUCK1 "																																								
	6	FLT_BUCK2_WOC	R	0x0																																									
	5	FLT_BUCK2_OV	R	0x0																																									
	4	FLT_BUCK2_UV	R	0x0																																									
	3	FLT_BUCK2_OCSDR	R	0x0																																									
	2	FLT_BUCK2_OCWR	R	0x0																																									
	1	FLT_BUCK2_OCWF	R	0x0																																									
	0	Reserved	R	0x0																																									
ADC_SAMPLE0MSB																																													
0x16	7:0	ADC_SAMPLE0MSB	R		<table border="1"> <thead> <tr> <th colspan="2">Upper Byte of Temperature Sample (Combine With LSB for 16-Bit Value)</th> </tr> <tr> <th>Source</th> <th>Temp. Sensor</th> </tr> </thead> <tbody> <tr> <td>Range</td> <td>±200 °C</td> </tr> <tr> <td>Format</td> <td>s.13.2</td> </tr> <tr> <td>Units</td> <td>Temperature °C</td> </tr> <tr> <td>0x0000</td> <td>0</td> </tr> <tr> <td>0x0001</td> <td>0.25</td> </tr> <tr> <td>0x0002</td> <td>0.5</td> </tr> <tr> <td>0x0003</td> <td>0.75</td> </tr> <tr> <td>0x0004</td> <td>1</td> </tr> <tr> <td>...</td> <td></td> </tr> <tr> <td>0x0010</td> <td>4</td> </tr> <tr> <td>...</td> <td></td> </tr> <tr> <td>0x0100</td> <td>64</td> </tr> <tr> <td>...</td> <td></td> </tr> <tr> <td>0x0320</td> <td>200</td> </tr> <tr> <td>0xFCE0</td> <td>-200</td> </tr> <tr> <td>0xFCE1</td> <td>-199.75</td> </tr> <tr> <td>...</td> <td></td> </tr> <tr> <td>0xFFFF</td> <td>-0.25</td> </tr> </tbody> </table>	Upper Byte of Temperature Sample (Combine With LSB for 16-Bit Value)		Source	Temp. Sensor	Range	±200 °C	Format	s.13.2	Units	Temperature °C	0x0000	0	0x0001	0.25	0x0002	0.5	0x0003	0.75	0x0004	1	...		0x0010	4	...		0x0100	64	...		0x0320	200	0xFCE0	-200	0xFCE1	-199.75	...		0xFFFF	-0.25
Upper Byte of Temperature Sample (Combine With LSB for 16-Bit Value)																																													
Source	Temp. Sensor																																												
Range	±200 °C																																												
Format	s.13.2																																												
Units	Temperature °C																																												
0x0000	0																																												
0x0001	0.25																																												
0x0002	0.5																																												
0x0003	0.75																																												
0x0004	1																																												
...																																													
0x0010	4																																												
...																																													
0x0100	64																																												
...																																													
0x0320	200																																												
0xFCE0	-200																																												
0xFCE1	-199.75																																												
...																																													
0xFFFF	-0.25																																												
ADC_SAMPLE0LSB																																													
0x17	7:0	ADC_SAMPLE0LSB	R		Lower byte of temperature sample (combine with MSB for 16-bit value). See " ADC_SAMPLE0MSB " for decode																																								

Address	Bit	Name	R/W	Default	Description																																								
ADC_SAMPLE1PH1MSB																																													
0x18	7:0	ADC_SAMPLE1PH1MSB	R		<table border="1"> <thead> <tr> <th colspan="2">Upper Byte of Buck1, Phase1 Output Current (Combine with LSB for 16-Bit Value)</th> </tr> <tr> <th>Source</th> <th>I_{SENSE}</th> </tr> </thead> <tbody> <tr> <td>Range</td> <td>±8.192A</td> </tr> <tr> <td>Format</td> <td>S13.2</td> </tr> <tr> <td>Units</td> <td>Current (mA)</td> </tr> <tr> <td>0x0000</td> <td>0</td> </tr> <tr> <td>0x0001</td> <td>0.25</td> </tr> <tr> <td>0x0002</td> <td>0.5</td> </tr> <tr> <td>0x0003</td> <td>0.75</td> </tr> <tr> <td>0x0004</td> <td>1</td> </tr> <tr> <td>...</td> <td></td> </tr> <tr> <td>0x0010</td> <td>4</td> </tr> <tr> <td>...</td> <td></td> </tr> <tr> <td>0x0100</td> <td>64</td> </tr> <tr> <td>...</td> <td></td> </tr> <tr> <td>0x7FFF</td> <td>8191.75</td> </tr> <tr> <td>0x8000</td> <td>-8192</td> </tr> <tr> <td>0x8001</td> <td>-8191.75</td> </tr> <tr> <td>...</td> <td></td> </tr> <tr> <td>0xFFFF</td> <td>-0.25</td> </tr> </tbody> </table>	Upper Byte of Buck1, Phase1 Output Current (Combine with LSB for 16-Bit Value)		Source	I _{SENSE}	Range	±8.192A	Format	S13.2	Units	Current (mA)	0x0000	0	0x0001	0.25	0x0002	0.5	0x0003	0.75	0x0004	1	...		0x0010	4	...		0x0100	64	...		0x7FFF	8191.75	0x8000	-8192	0x8001	-8191.75	...		0xFFFF	-0.25
Upper Byte of Buck1, Phase1 Output Current (Combine with LSB for 16-Bit Value)																																													
Source	I _{SENSE}																																												
Range	±8.192A																																												
Format	S13.2																																												
Units	Current (mA)																																												
0x0000	0																																												
0x0001	0.25																																												
0x0002	0.5																																												
0x0003	0.75																																												
0x0004	1																																												
...																																													
0x0010	4																																												
...																																													
0x0100	64																																												
...																																													
0x7FFF	8191.75																																												
0x8000	-8192																																												
0x8001	-8191.75																																												
...																																													
0xFFFF	-0.25																																												
ADC_SAMPLE1PH1LSB																																													
0x19	7:0	ADC_SAMPLE1PH1LSB	R		Lower byte of Buck1, Phase1 output current (combine with MSB for 16-bit value). See "ADC_SAMPLE1PH1MSB" for decode																																								
ADC_SAMPLE1PH2MSB																																													
0x1A	7:0	ADC_SAMPLE1PH2MSB	R		Upper byte of Buck1, Phase2 output current (combine with LSB for 16-bit value). See "ADC_SAMPLE1PH1MSB" for decode																																								
ADC_SAMPLE1PH2LSB																																													
0x1B	7:0	ADC_SAMPLE1PH2LSB	R		Lower byte of Buck1, Phase2 output current (combine with MSB for 16-bit value). See "ADC_SAMPLE1PH1MSB" for decode																																								
ADC_SAMPLE1PH3MSB																																													
0x1C	7:0	ADC_SAMPLE1PH3MSB	R		Upper byte of Buck1, Phase3 output current (combine with LSB for 16-bit value). See "ADC_SAMPLE1PH1MSB" for decode																																								
ADC_SAMPLE1PH3LSB																																													
0x1D	7:0	ADC_SAMPLE1PH3LSB	R		Lower byte of Buck1, Phase3 output current (combine with MSB for 16-bit value). See "ADC_SAMPLE1PH1MSB" for decode																																								
ADC_SAMPLE1PH4MSB																																													
0x1E	7:0	ADC_SAMPLE1PH4MSB	R		Upper byte of Buck1, Phase4 output current (combine with LSB for 16-bit value). See "ADC_SAMPLE1PH1MSB" for decode																																								
ADC_SAMPLE1PH4LSB																																													
0x1F	7:0	ADC_SAMPLE1PH4LSB	R		Lower byte of Buck1, Phase4 output current (combine with MSB for 16-bit value). See "ADC_SAMPLE1PH1MSB" for decode																																								

Address	Bit	Name	R/W	Default	Description																																								
ADC_SAMPLE1TMSB																																													
0x20	7:0	ADC_SAMPLE1TMSB	R		<table border="1"> <tr> <td colspan="2">Upper Byte of Buck1, Total Output Current Reading (Combine with LSB for 16-Bit Value)</td> </tr> <tr> <td>Source</td> <td>I_{SENSE}</td> </tr> <tr> <td>Range</td> <td>±32.768A</td> </tr> <tr> <td>Format</td> <td>s.15</td> </tr> <tr> <td>Units</td> <td>Current (mA)</td> </tr> <tr> <td>0x0000</td> <td>0</td> </tr> <tr> <td>0x0001</td> <td>1</td> </tr> <tr> <td>0x0002</td> <td>2</td> </tr> <tr> <td>0x0003</td> <td>3</td> </tr> <tr> <td>0x0004</td> <td>4</td> </tr> <tr> <td>...</td> <td></td> </tr> <tr> <td>0x0010</td> <td>16</td> </tr> <tr> <td>...</td> <td></td> </tr> <tr> <td>0x0100</td> <td>256</td> </tr> <tr> <td>...</td> <td></td> </tr> <tr> <td>0x7FFF</td> <td>32767</td> </tr> <tr> <td>0x8000</td> <td>-32768</td> </tr> <tr> <td>0x8001</td> <td>-32767</td> </tr> <tr> <td>...</td> <td></td> </tr> <tr> <td>0xFFFF</td> <td>-1</td> </tr> </table>	Upper Byte of Buck1, Total Output Current Reading (Combine with LSB for 16-Bit Value)		Source	I_{SENSE}	Range	±32.768A	Format	s.15	Units	Current (mA)	0x0000	0	0x0001	1	0x0002	2	0x0003	3	0x0004	4	...		0x0010	16	...		0x0100	256	...		0x7FFF	32767	0x8000	-32768	0x8001	-32767	...		0xFFFF	-1
Upper Byte of Buck1, Total Output Current Reading (Combine with LSB for 16-Bit Value)																																													
Source	I_{SENSE}																																												
Range	±32.768A																																												
Format	s.15																																												
Units	Current (mA)																																												
0x0000	0																																												
0x0001	1																																												
0x0002	2																																												
0x0003	3																																												
0x0004	4																																												
...																																													
0x0010	16																																												
...																																													
0x0100	256																																												
...																																													
0x7FFF	32767																																												
0x8000	-32768																																												
0x8001	-32767																																												
...																																													
0xFFFF	-1																																												
ADC_SAMPLE1TLSB																																													
0x21	7:0	ADC_SAMPLE1TLSB	R		Lower byte of Buck1, total output current reading (combine with MSB for 16-bit value). See "ADC_SAMPLE1TMSB" for decode																																								

Address	Bit	Name	R/W	Default	Description																																						
ADC_SAMPLE2MSB																																											
0x22	7:0	ADC_SAMPLE2MSB	R		<div style="border: 1px solid black; padding: 5px;"> Upper Byte of Buck1, PVIN Sample (Combine with LSB for 16-Bit Value) <table border="1" style="width: 100%; border-collapse: collapse;"> <thead> <tr> <th>Source</th> <th>PVIN</th> </tr> </thead> <tbody> <tr> <td>Range</td> <td>±8.192V</td> </tr> <tr> <td>Format</td> <td>s.13.2</td> </tr> <tr> <td>Units</td> <td>Voltage (mV)</td> </tr> <tr> <td>0x0000</td> <td>0</td> </tr> <tr> <td>0x0001</td> <td>0.25</td> </tr> <tr> <td>0x0002</td> <td>0.5</td> </tr> <tr> <td>0x0003</td> <td>0.75</td> </tr> <tr> <td>0x0004</td> <td>1</td> </tr> <tr> <td>...</td> <td></td> </tr> <tr> <td>0x0010</td> <td>4</td> </tr> <tr> <td>...</td> <td></td> </tr> <tr> <td>0x0100</td> <td>64</td> </tr> <tr> <td>...</td> <td></td> </tr> <tr> <td>0x7FFF</td> <td>8191.75</td> </tr> <tr> <td>0x8000</td> <td>-8192</td> </tr> <tr> <td>0x8001</td> <td>-8191.75</td> </tr> <tr> <td>...</td> <td></td> </tr> <tr> <td>0xFFFF</td> <td>-0.25</td> </tr> </tbody> </table> </div>	Source	PVIN	Range	±8.192V	Format	s.13.2	Units	Voltage (mV)	0x0000	0	0x0001	0.25	0x0002	0.5	0x0003	0.75	0x0004	1	...		0x0010	4	...		0x0100	64	...		0x7FFF	8191.75	0x8000	-8192	0x8001	-8191.75	...		0xFFFF	-0.25
Source	PVIN																																										
Range	±8.192V																																										
Format	s.13.2																																										
Units	Voltage (mV)																																										
0x0000	0																																										
0x0001	0.25																																										
0x0002	0.5																																										
0x0003	0.75																																										
0x0004	1																																										
...																																											
0x0010	4																																										
...																																											
0x0100	64																																										
...																																											
0x7FFF	8191.75																																										
0x8000	-8192																																										
0x8001	-8191.75																																										
...																																											
0xFFFF	-0.25																																										
ADC_SAMPLE2LSB																																											
0x23	7:0	ADC_SAMPLE2LSB	R		Lower byte of Buck1 PVIN reading (combine with MSB for 16-bit value). See "ADC_SAMPLE2MSB" for decode																																						

Address	Bit	Name	R/W	Default	Description																																								
ADC_SAMPLE3MSB																																													
0x24	7:0	ADC_SAMPLE3MSB	R		<table border="1"> <thead> <tr> <th colspan="2">Upper Byte of Buck1, V_{OUT} Sample (Combine with LSB for 16-Bit Value)</th> </tr> <tr> <th>Source</th> <th>V_{OUT}</th> </tr> </thead> <tbody> <tr> <td>Range</td> <td>$\pm 8.192V$</td> </tr> <tr> <td>Format</td> <td>s.13.2</td> </tr> <tr> <td>Units</td> <td>Voltage (mV)</td> </tr> <tr> <td>0x0000</td> <td>0</td> </tr> <tr> <td>0x0001</td> <td>0.25</td> </tr> <tr> <td>0x0002</td> <td>0.5</td> </tr> <tr> <td>0x0003</td> <td>0.75</td> </tr> <tr> <td>0x0004</td> <td>1</td> </tr> <tr> <td>...</td> <td></td> </tr> <tr> <td>0x0010</td> <td>4</td> </tr> <tr> <td>...</td> <td></td> </tr> <tr> <td>0x0100</td> <td>64</td> </tr> <tr> <td>...</td> <td></td> </tr> <tr> <td>0x7FFF</td> <td>8191.75</td> </tr> <tr> <td>0x8000</td> <td>-8192</td> </tr> <tr> <td>0x8001</td> <td>-8191.75</td> </tr> <tr> <td>...</td> <td></td> </tr> <tr> <td>0xFFFF</td> <td>-0.25</td> </tr> </tbody> </table>	Upper Byte of Buck1, V_{OUT} Sample (Combine with LSB for 16-Bit Value)		Source	V_{OUT}	Range	$\pm 8.192V$	Format	s.13.2	Units	Voltage (mV)	0x0000	0	0x0001	0.25	0x0002	0.5	0x0003	0.75	0x0004	1	...		0x0010	4	...		0x0100	64	...		0x7FFF	8191.75	0x8000	-8192	0x8001	-8191.75	...		0xFFFF	-0.25
Upper Byte of Buck1, V_{OUT} Sample (Combine with LSB for 16-Bit Value)																																													
Source	V_{OUT}																																												
Range	$\pm 8.192V$																																												
Format	s.13.2																																												
Units	Voltage (mV)																																												
0x0000	0																																												
0x0001	0.25																																												
0x0002	0.5																																												
0x0003	0.75																																												
0x0004	1																																												
...																																													
0x0010	4																																												
...																																													
0x0100	64																																												
...																																													
0x7FFF	8191.75																																												
0x8000	-8192																																												
0x8001	-8191.75																																												
...																																													
0xFFFF	-0.25																																												
ADC_SAMPLE3LSB																																													
0x25	7:0	ADC_SAMPLE3LSB	R		Lower byte of Buck1 V_{OUT} reading (combine with MSB for 16-bit value). See " ADC_SAMPLE3MSB " for decode																																								
ADC_SAMPLE4PH1MSB																																													
0x26	7:0	ADC_SAMPLE4PH1MSB	R		Upper byte of Buck2, Phase1 output current (combine with LSB for 16-bit value). See " ADC_SAMPLE1PH1MSB " on page 47 for decode																																								
ADC_SAMPLE4PH1LSB																																													
0x27	7:0	ADC_SAMPLE4PH1LSB	R		Lower byte of Buck2, Phase1 output current (combine with MSB for 16-bit value). See " ADC_SAMPLE1PH1MSB " on page 47 for decode																																								
ADC_SAMPLE4PH2MSB																																													
0x28	7:0	ADC_SAMPLE4PH2MSB	R		Upper byte of Buck2, Phase2 output current (combine with LSB for 16-bit value). See " ADC_SAMPLE1PH1MSB " on page 47 for decode																																								
ADC_SAMPLE4PH2LSB																																													
0x29	7:0	ADC_SAMPLE4PH2LSB	R		Lower byte of Buck2, Phase2 output current (combine with MSB for 16-bit value). See " ADC_SAMPLE1PH1MSB " on page 47 for decode																																								
ADC_SAMPLE4TMSB																																													
0x2A	7:0	ADC_SAMPLE4TMSB	R		Upper byte of Buck2, total output current (combine with LSB for 16-bit value). See " ADC_SAMPLE1TMSB " on page 48 for decode																																								
ADC_SAMPLE4TLSB																																													
0x2B	7:0	ADC_SAMPLE4TLSB	R		Lower byte of Buck2, total output current (combine with MSB for 16-bit value). See " ADC_SAMPLE1TMSB " on page 48 for decode																																								

Address	Bit	Name	R/W	Default	Description																																						
ADC_SAMPLE5MSB																																											
0x2C	7:0	ADC_SAMPLE5MSB	R		Upper byte of Buck2, PVIN reading (combine with LSB for 16-bit value). See " ADC_SAMPLE2MSB " on page 49 for decode																																						
ADC_SAMPLE5LSB																																											
0x2D	7:0	ADC_SAMPLE5LSB	R		Lower byte of Buck2, PVIN reading (combine with MSB for 16-bit value). See " ADC_SAMPLE2MSB " on page 49 for decode																																						
ADC_SAMPLE6MSB																																											
0x2E	7:0	ADC_SAMPLE6MSB	R		Upper byte of Buck2, V _{OUT} reading (Combine with LSB for 16-bit value). See " ADC_SAMPLE3MSB " on page 50 for decode																																						
ADC_SAMPLE6LSB																																											
0x2F	7:0	ADC_SAMPLE6LSB	R		Lower byte of Buck2, V _{OUT} reading (combine with MSB for 16-bit value). See " ADC_SAMPLE3MSB " on page 50 for decode.																																						
ADC_AUX0MSB																																											
0x30	7:0	ADC_AUX0MSB	R		<p>Upper Byte of ADC Auxiliary Input #1 (combine with LSB for 16-bit value). Can be used in IO_PINMODE[3:0] = 0xC, 0xD to measure external voltage with internal ADC.</p> <table border="1"> <thead> <tr> <th>Source</th> <th>AUX0</th> </tr> </thead> <tbody> <tr> <td>Range</td> <td>±8.192V</td> </tr> <tr> <td>Format</td> <td>s.13.2</td> </tr> <tr> <td>Units</td> <td>Voltage (mV)</td> </tr> <tr> <td>0x0000</td> <td>0</td> </tr> <tr> <td>0x0001</td> <td>0.25</td> </tr> <tr> <td>0x0002</td> <td>0.5</td> </tr> <tr> <td>0x0003</td> <td>0.75</td> </tr> <tr> <td>0x0004</td> <td>1</td> </tr> <tr> <td>...</td> <td></td> </tr> <tr> <td>0x0010</td> <td>4</td> </tr> <tr> <td>...</td> <td></td> </tr> <tr> <td>0x0100</td> <td>64</td> </tr> <tr> <td>...</td> <td></td> </tr> <tr> <td>0x7FFF</td> <td>8191.75</td> </tr> <tr> <td>0x8000</td> <td>-8192</td> </tr> <tr> <td>0x8001</td> <td>-8191.75</td> </tr> <tr> <td>...</td> <td></td> </tr> <tr> <td>0xFFFF</td> <td>-0.25</td> </tr> </tbody> </table>	Source	AUX0	Range	±8.192V	Format	s.13.2	Units	Voltage (mV)	0x0000	0	0x0001	0.25	0x0002	0.5	0x0003	0.75	0x0004	1	...		0x0010	4	...		0x0100	64	...		0x7FFF	8191.75	0x8000	-8192	0x8001	-8191.75	...		0xFFFF	-0.25
Source	AUX0																																										
Range	±8.192V																																										
Format	s.13.2																																										
Units	Voltage (mV)																																										
0x0000	0																																										
0x0001	0.25																																										
0x0002	0.5																																										
0x0003	0.75																																										
0x0004	1																																										
...																																											
0x0010	4																																										
...																																											
0x0100	64																																										
...																																											
0x7FFF	8191.75																																										
0x8000	-8192																																										
0x8001	-8191.75																																										
...																																											
0xFFFF	-0.25																																										
ADC_AUX0LSB																																											
0x31	7:0	ADC_AUX0LSB	R		Lower byte of ADC auxiliary input #1 (combine with MSB for 16-bit value). See " ADC_AUX0MSB " for decode																																						
ADC_AUX1MSB																																											
0x32	7:0	ADC_AUX1MSB	R		Upper byte of ADC auxiliary input #2 (combine with LSB for 16-bit value). Can be used in IO_PINMODE[3:0] = 0xC, 0xD to measure external voltage with internal ADC. See " ADC_AUX0MSB " for decode																																						

Address	Bit	Name	R/W	Default	Description						
ADC_AUX1LSB											
0x33	7:0	ADC_AUX1LSB	R		Lower byte of ADC auxiliary input #2 (combine with MSB for 16-bit value). See " ADC_AUX0MSB " for decode.						
IO_SPICFG											
0x43	7	IO_I2C_SPEED	R/W	0x0	<table border="1"> <thead> <tr> <th colspan="2">I²C Speed Control</th> </tr> </thead> <tbody> <tr> <td>0x0</td> <td>Low speed glitch and slew filters by default, high speed filters selectable by bus command.</td> </tr> <tr> <td>0x1</td> <td>Glitch and slew filters set for high speed 3.4MHz mode.</td> </tr> </tbody> </table>	I ² C Speed Control		0x0	Low speed glitch and slew filters by default, high speed filters selectable by bus command.	0x1	Glitch and slew filters set for high speed 3.4MHz mode.
	I ² C Speed Control										
	0x0	Low speed glitch and slew filters by default, high speed filters selectable by bus command.									
	0x1	Glitch and slew filters set for high speed 3.4MHz mode.									
	6	IO_SDA_SLEWFLTR	R/W	0x0	<table border="1"> <thead> <tr> <th colspan="2">Transmit Slew Rate Control for I²C SDA</th> </tr> </thead> <tbody> <tr> <td>0x0</td> <td>Disables slew filtering.</td> </tr> <tr> <td>0x1</td> <td>Enables slew filtering.</td> </tr> </tbody> </table>	Transmit Slew Rate Control for I ² C SDA		0x0	Disables slew filtering.	0x1	Enables slew filtering.
	Transmit Slew Rate Control for I ² C SDA										
	0x0	Disables slew filtering.									
0x1	Enables slew filtering.										
5	IO_SPIRWPOL	R/W	0x0	<table border="1"> <thead> <tr> <th colspan="2">R/W polarity</th> </tr> </thead> <tbody> <tr> <td>0x0</td> <td>R/W. 1 = Read, 0 = Write</td> </tr> <tr> <td>0x1</td> <td>R/W. 1 = Write, 0 = Read</td> </tr> </tbody> </table>	R/W polarity		0x0	R/W. 1 = Read, 0 = Write	0x1	R/W. 1 = Write, 0 = Read	
R/W polarity											
0x0	R/W. 1 = Read, 0 = Write										
0x1	R/W. 1 = Write, 0 = Read										
4	IO_IRQ_CMOS	R/W	0x1	<table border="1"> <thead> <tr> <th colspan="2">IRQ Type</th> </tr> </thead> <tbody> <tr> <td>0x0</td> <td>Open-drain output</td> </tr> <tr> <td>0x1</td> <td>CMOS output</td> </tr> </tbody> </table>	IRQ Type		0x0	Open-drain output	0x1	CMOS output	
IRQ Type											
0x0	Open-drain output										
0x1	CMOS output										
3	IO_IRQ_INVERT	R/W	0x1	<table border="1"> <thead> <tr> <th colspan="2">IRQ Polarity</th> </tr> </thead> <tbody> <tr> <td>0x0</td> <td>Active high</td> </tr> <tr> <td>0x1</td> <td>Active low</td> </tr> </tbody> </table>	IRQ Polarity		0x0	Active high	0x1	Active low	
IRQ Polarity											
0x0	Active high										
0x1	Active low										
2	IO_SPICPOL	R/W	0x0	<table border="1"> <thead> <tr> <th colspan="2">SPI Clock Polarity</th> </tr> </thead> <tbody> <tr> <td>0x0</td> <td>Active high</td> </tr> <tr> <td>0x1</td> <td>Active low</td> </tr> </tbody> </table>	SPI Clock Polarity		0x0	Active high	0x1	Active low	
SPI Clock Polarity											
0x0	Active high										
0x1	Active low										
1	IO_SPICPHA	R/W	0x0	<table border="1"> <thead> <tr> <th colspan="2">SPI Clock Phase</th> </tr> </thead> <tbody> <tr> <td>0x0</td> <td>Sample on the leading (first) clock edge. Note: Data must be stable for a half cycle before the first clock cycle</td> </tr> <tr> <td>0x1</td> <td>Sample on the trailing (second) clock edge, regardless of whether that clock edge is rising or falling</td> </tr> </tbody> </table>	SPI Clock Phase		0x0	Sample on the leading (first) clock edge. Note: Data must be stable for a half cycle before the first clock cycle	0x1	Sample on the trailing (second) clock edge, regardless of whether that clock edge is rising or falling	
SPI Clock Phase											
0x0	Sample on the leading (first) clock edge. Note: Data must be stable for a half cycle before the first clock cycle										
0x1	Sample on the trailing (second) clock edge, regardless of whether that clock edge is rising or falling										

Address	Bit	Name	R/W	Default	Description						
	0	IO_SPIMODE	R/W	0x1	<table border="1"> <thead> <tr> <th colspan="2">SPI Mode Selection</th> </tr> </thead> <tbody> <tr> <td>0x0</td> <td>Byte Mode Command Byte: R/W, AINC, 0x0, 0x0, 0x0, 0x0, P1, P0 Address Byte: A7, A6, A5, A4, A3, A2, A1, A0 Data Byte: D7, D6, D5, D4, D3, D2, D1, D0</td> </tr> <tr> <td>0x1</td> <td>Byte Mode with Packet Length Field Command Byte: R/W, AINC, 0x0, 0x0, 0x0, 0x0, P1, P0 Address Byte: A7, A6, A5, A4, A3, A2, A1, A0 Packet Length Byte: L7, L6, L5, L4, L3, L2, L1, L0 Data Byte: D7, D6, D5, D4, D3, D2, D1, D0</td> </tr> </tbody> </table>	SPI Mode Selection		0x0	Byte Mode Command Byte: R/W, AINC, 0x0, 0x0, 0x0, 0x0, P1, P0 Address Byte: A7, A6, A5, A4, A3, A2, A1, A0 Data Byte: D7, D6, D5, D4, D3, D2, D1, D0	0x1	Byte Mode with Packet Length Field Command Byte: R/W, AINC, 0x0, 0x0, 0x0, 0x0, P1, P0 Address Byte: A7, A6, A5, A4, A3, A2, A1, A0 Packet Length Byte: L7, L6, L5, L4, L3, L2, L1, L0 Data Byte: D7, D6, D5, D4, D3, D2, D1, D0
SPI Mode Selection											
0x0	Byte Mode Command Byte: R/W, AINC, 0x0, 0x0, 0x0, 0x0, P1, P0 Address Byte: A7, A6, A5, A4, A3, A2, A1, A0 Data Byte: D7, D6, D5, D4, D3, D2, D1, D0										
0x1	Byte Mode with Packet Length Field Command Byte: R/W, AINC, 0x0, 0x0, 0x0, 0x0, P1, P0 Address Byte: A7, A6, A5, A4, A3, A2, A1, A0 Packet Length Byte: L7, L6, L5, L4, L3, L2, L1, L0 Data Byte: D7, D6, D5, D4, D3, D2, D1, D0										
IO_MODECTRL											
0x44	7	IO_BUCK1_EN	R/W	0x1	<table border="1"> <thead> <tr> <th colspan="2">Enable for Buck1</th> </tr> </thead> <tbody> <tr> <td>0x0</td> <td>Buck1 disabled</td> </tr> <tr> <td>0x1</td> <td>Buck1 enabled</td> </tr> </tbody> </table>	Enable for Buck1		0x0	Buck1 disabled	0x1	Buck1 enabled
	Enable for Buck1										
	0x0	Buck1 disabled									
	0x1	Buck1 enabled									
	6	IO_BUCK2_EN	R/W	0x1	<table border="1"> <thead> <tr> <th colspan="2">Enable for Buck2</th> </tr> </thead> <tbody> <tr> <td>0x0</td> <td>Buck2 disabled</td> </tr> <tr> <td>0x1</td> <td>Buck2 enabled</td> </tr> </tbody> </table>	Enable for Buck2		0x0	Buck2 disabled	0x1	Buck2 enabled
	Enable for Buck2										
0x0	Buck2 disabled										
0x1	Buck2 enabled										
5:3	IO_MODECTRLRSVD	R	0x0	Reserved							
2	IO_ENVPPULLDOWN	R/W	0x1	<table border="1"> <thead> <tr> <th colspan="2">Enable for Weak Pull-Down on EN/VPP Pin</th> </tr> </thead> <tbody> <tr> <td>0x0</td> <td>Weak pull-down disabled.</td> </tr> <tr> <td>0x1</td> <td>Weak pull-down enabled.</td> </tr> </tbody> </table>	Enable for Weak Pull-Down on EN/VPP Pin		0x0	Weak pull-down disabled.	0x1	Weak pull-down enabled.	
Enable for Weak Pull-Down on EN/VPP Pin											
0x0	Weak pull-down disabled.										
0x1	Weak pull-down enabled.										
1	RSVD	R/W	0x0	Reserved							
0	RSVD	R/W	0x0	Reserved							

Address	Bit	Name	R/W	Default	Description																																																														
IO_RSTDVS																																																																			
0x45	7:6	Reserved	R	0x0	N/A																																																														
	5:4	IO_RSTDVS_CTRL	R/W	0x1	When the pin WDOG_RST is asserted, the control logic checks this configuration register and restores the corresponding bucks. <table border="1" data-bbox="740 415 1409 575"> <tr> <td rowspan="2">Bit [0]: Buck1</td> <td>0x0</td> <td>Do Nothing</td> </tr> <tr> <td>0x1</td> <td>Reset Buck1</td> </tr> <tr> <td rowspan="2">Bit [1]: Buck2</td> <td>0x0</td> <td>Do Nothing</td> </tr> <tr> <td>0x1</td> <td>Reset Buck2</td> </tr> </table>	Bit [0]: Buck1	0x0	Do Nothing	0x1	Reset Buck1	Bit [1]: Buck2	0x0	Do Nothing	0x1	Reset Buck2																																																				
	Bit [0]: Buck1	0x0	Do Nothing																																																																
0x1		Reset Buck1																																																																	
Bit [1]: Buck2	0x0	Do Nothing																																																																	
	0x1	Reset Buck2																																																																	
3	IO_NO_DVSSHUTDN	R/W	0x0	Automatic DVS Power-Down Control <table border="1" data-bbox="740 617 1409 789"> <tr> <td>0x0</td> <td>Enable the automatic DVS power-down when the EN register or pin is deasserted</td> </tr> <tr> <td>0x1</td> <td>Disable the automatic DVS power-down when the EN register or pin is deasserted</td> </tr> </table>	0x0	Enable the automatic DVS power-down when the EN register or pin is deasserted	0x1	Disable the automatic DVS power-down when the EN register or pin is deasserted																																																											
0x0	Enable the automatic DVS power-down when the EN register or pin is deasserted																																																																		
0x1	Disable the automatic DVS power-down when the EN register or pin is deasserted																																																																		
2:0	IO_DEBOUNCETIME	R/W	0x0	Delay Before Start Reset DVS when the WDOG_RST Pin is Asserted <table border="1" data-bbox="740 835 1409 1230"> <thead> <tr> <th></th> <th>Delay Time</th> <th>Number of Clocks (32kHz)</th> </tr> </thead> <tbody> <tr> <td>0x0</td> <td>0μs</td> <td>0</td> </tr> <tr> <td>0x1</td> <td>1.56ms</td> <td>50</td> </tr> <tr> <td>0x2</td> <td>3.125ms</td> <td>100</td> </tr> <tr> <td>0x3</td> <td>6.25ms</td> <td>200</td> </tr> <tr> <td>0x4</td> <td>12.5ms</td> <td>400</td> </tr> <tr> <td>0x5</td> <td>9ms</td> <td>288</td> </tr> <tr> <td>0x6</td> <td>15.25ms</td> <td>488</td> </tr> <tr> <td>0x7</td> <td>14.5ms</td> <td>464</td> </tr> </tbody> </table>		Delay Time	Number of Clocks (32kHz)	0x0	0 μ s	0	0x1	1.56ms	50	0x2	3.125ms	100	0x3	6.25ms	200	0x4	12.5ms	400	0x5	9ms	288	0x6	15.25ms	488	0x7	14.5ms	464																																				
					Delay Time	Number of Clocks (32kHz)																																																													
				0x0	0 μ s	0																																																													
				0x1	1.56ms	50																																																													
				0x2	3.125ms	100																																																													
				0x3	6.25ms	200																																																													
				0x4	12.5ms	400																																																													
				0x5	9ms	288																																																													
				0x6	15.25ms	488																																																													
				0x7	14.5ms	464																																																													
IO_PINMODE																																																																			
0x46	7:4	Reserved	R	0x0	Reserved																																																														
	3:0	IO_PINMODE	R/W	0x0	<table border="1" data-bbox="740 1352 1442 1793"> <thead> <tr> <th>Pin Mode</th> <th>MPIO0</th> <th>MPIO1</th> <th>MPIO2</th> <th>MPIO3</th> <th>GPIO0</th> <th>GPIO1</th> </tr> </thead> <tbody> <tr> <td>0x0</td> <td>SCK</td> <td>SS_B</td> <td>MOSI</td> <td>MISO</td> <td>SCL</td> <td>SDA</td> </tr> <tr> <td>0x1</td> <td>SCK</td> <td>SS_B</td> <td>MOSI</td> <td>MISO</td> <td>EN_A</td> <td>EN_B</td> </tr> <tr> <td>0x3</td> <td>SCK</td> <td>SS_B</td> <td>MOSI</td> <td>MISO</td> <td>DVS1_0</td> <td>DVS2_0</td> </tr> <tr> <td>0x4</td> <td>DVS_PIN1</td> <td>DVS_PIN0</td> <td>PGOOD1</td> <td>PGOOD2</td> <td>SCL</td> <td>SDA</td> </tr> <tr> <td>0x5</td> <td>DVS1_0</td> <td>DVS1_1</td> <td>DVS2_0</td> <td>DVS2_1</td> <td>SCL</td> <td>SDA</td> </tr> <tr> <td>0x6</td> <td>DVS1_0</td> <td>DVS2_0</td> <td>PGOOD1</td> <td>PGOOD2</td> <td>SCL</td> <td>SDA</td> </tr> <tr> <td>0xD</td> <td>ADC_IN0</td> <td>ADC_IN1</td> <td>PGOOD1</td> <td>PGOOD2</td> <td>SCL</td> <td>SDA</td> </tr> <tr> <td>0xE</td> <td>ADC_IN0</td> <td>ADC_IN1</td> <td>DVS_PIN1</td> <td>DVS_PIN0</td> <td>SCL</td> <td>SDA</td> </tr> </tbody> </table> <p>Note: Any Pin Mode setting not shown is Reserved and should not be used. Refer to "/I/O Pin Configuration" on page 9.</p>	Pin Mode	MPIO0	MPIO1	MPIO2	MPIO3	GPIO0	GPIO1	0x0	SCK	SS_B	MOSI	MISO	SCL	SDA	0x1	SCK	SS_B	MOSI	MISO	EN_A	EN_B	0x3	SCK	SS_B	MOSI	MISO	DVS1_0	DVS2_0	0x4	DVS_PIN1	DVS_PIN0	PGOOD1	PGOOD2	SCL	SDA	0x5	DVS1_0	DVS1_1	DVS2_0	DVS2_1	SCL	SDA	0x6	DVS1_0	DVS2_0	PGOOD1	PGOOD2	SCL	SDA	0xD	ADC_IN0	ADC_IN1	PGOOD1	PGOOD2	SCL	SDA	0xE	ADC_IN0	ADC_IN1	DVS_PIN1	DVS_PIN0	SCL
Pin Mode	MPIO0	MPIO1	MPIO2	MPIO3	GPIO0	GPIO1																																																													
0x0	SCK	SS_B	MOSI	MISO	SCL	SDA																																																													
0x1	SCK	SS_B	MOSI	MISO	EN_A	EN_B																																																													
0x3	SCK	SS_B	MOSI	MISO	DVS1_0	DVS2_0																																																													
0x4	DVS_PIN1	DVS_PIN0	PGOOD1	PGOOD2	SCL	SDA																																																													
0x5	DVS1_0	DVS1_1	DVS2_0	DVS2_1	SCL	SDA																																																													
0x6	DVS1_0	DVS2_0	PGOOD1	PGOOD2	SCL	SDA																																																													
0xD	ADC_IN0	ADC_IN1	PGOOD1	PGOOD2	SCL	SDA																																																													
0xE	ADC_IN0	ADC_IN1	DVS_PIN1	DVS_PIN0	SCL	SDA																																																													

Address	Bit	Name	R/W	Default	Description	
ADC_RATECCMDCM						
0x50	7:4	ADC_RATECCM	R/W	0x3	Sampling period when either one of the buck outputs is in CCM.	
					0x0	Off or One-shot Mode
					0x1	31.25µs
					0x2	62.5µs
					0x3	125µs
					0x4	250µs
					0x5	500µs
					0x6	1ms
					0x7	2ms
					0x8	4ms
					0x9	8ms
					0xA	16ms
					0xB	32ms
					0xC	64ms
					0xD	128ms
					0xE	256ms
					0xF	512ms
	3:0	ADC_RATEDCM	R/W	0x5	Sampling period when both buck outputs are in DCM.	
					0x0	Off or One-shot Mode
					0x1	31.25µs
					0x2	62.5µs
					0x3	125µs
					0x4	250µs
					0x5	500µs
					0x6	1ms
					0x7	2ms
					0x8	4ms
					0x9	8ms
					0xA	16ms
					0xB	32ms
					0xC	64ms
					0xD	128ms
					0xE	256ms
					0xF	512ms

Address	Bit	Name	R/W	Default	Description																																	
ADC_RATEIDLE																																						
0x51	7	ADC_SEQUENCER_DISABLE	R/W	0x0	0x0 = Enable the ADC conversion sequence. 0x1 = Disable the ADC conversion sequence.																																	
	6	ADC_ONE_SHOT_MODE	R/W	0x0	0x0 = Normal operation 0x1 = Trigger a one-shot ADC conversion																																	
	5:4	RESERVED	R/W	0x1	<i>Internal use only, do not modify these bits.</i>																																	
	3:0	ADC_RATEIDLE	R/W	0x6	<table border="1"> <thead> <tr> <th colspan="2">Sampling period when both buck outputs are disabled.</th> </tr> </thead> <tbody> <tr> <td>0x0</td> <td>Off or One-shot Mode</td> </tr> <tr> <td>0x1</td> <td>31.25µs</td> </tr> <tr> <td>0x2</td> <td>62.5µs</td> </tr> <tr> <td>0x3</td> <td>125µs</td> </tr> <tr> <td>0x4</td> <td>250µs</td> </tr> <tr> <td>0x5</td> <td>500µs</td> </tr> <tr> <td>0x6</td> <td>1ms</td> </tr> <tr> <td>0x7</td> <td>2ms</td> </tr> <tr> <td>0x8</td> <td>4ms</td> </tr> <tr> <td>0x9</td> <td>8ms</td> </tr> <tr> <td>0xA</td> <td>16ms</td> </tr> <tr> <td>0xB</td> <td>32ms</td> </tr> <tr> <td>0xC</td> <td>64ms</td> </tr> <tr> <td>0xD</td> <td>128ms</td> </tr> <tr> <td>0xE</td> <td>256ms</td> </tr> <tr> <td>0xF</td> <td>512ms</td> </tr> </tbody> </table>	Sampling period when both buck outputs are disabled.		0x0	Off or One-shot Mode	0x1	31.25µs	0x2	62.5µs	0x3	125µs	0x4	250µs	0x5	500µs	0x6	1ms	0x7	2ms	0x8	4ms	0x9	8ms	0xA	16ms	0xB	32ms	0xC	64ms	0xD	128ms	0xE	256ms	0xF
Sampling period when both buck outputs are disabled.																																						
0x0	Off or One-shot Mode																																					
0x1	31.25µs																																					
0x2	62.5µs																																					
0x3	125µs																																					
0x4	250µs																																					
0x5	500µs																																					
0x6	1ms																																					
0x7	2ms																																					
0x8	4ms																																					
0x9	8ms																																					
0xA	16ms																																					
0xB	32ms																																					
0xC	64ms																																					
0xD	128ms																																					
0xE	256ms																																					
0xF	512ms																																					

Address	Bit	Name	R/W	Default	Description																	
ADC_TEMPCFG																						
0x52	7	ADC_TEMPCCM	R/W	0x1	0x0 = Temperature measurement is disabled when either one of the buck outputs is in CCM. 0x1 = Temperature measurement is enabled when either one of the buck outputs is in CCM.																	
	6	ADC_TEMPDCM	R/W	0x1	0x0 = Temperature measurement is disabled when both buck outputs are in DCM. 0x1 = Temperature measurement is enabled when both buck outputs are in DCM.																	
	5	ADC_TEMPIDLE	R/W	0x1	0x0 = Temperature measurement is disabled when both buck outputs are OFF. 0x1 = Temperature measurement is enabled when both buck outputs are OFF.																	
	4:3	RESERVED	R	0x0																		
	3:0	ADC_TEMPIIR	R/W	0x6	<table border="1"> <thead> <tr> <th colspan="2">Temperature IIR coefficient.</th> </tr> </thead> <tbody> <tr> <td>0x0</td> <td>1</td> </tr> <tr> <td>0x1</td> <td>1/2</td> </tr> <tr> <td>0x2</td> <td>1/4</td> </tr> <tr> <td>0x3</td> <td>1/8</td> </tr> <tr> <td>0x4</td> <td>1/16</td> </tr> <tr> <td>0x5</td> <td>1/32</td> </tr> <tr> <td>0x6</td> <td>1/64</td> </tr> <tr> <td>0x7</td> <td>1/128</td> </tr> </tbody> </table>	Temperature IIR coefficient.		0x0	1	0x1	1/2	0x2	1/4	0x3	1/8	0x4	1/16	0x5	1/32	0x6	1/64	0x7
Temperature IIR coefficient.																						
0x0	1																					
0x1	1/2																					
0x2	1/4																					
0x3	1/8																					
0x4	1/16																					
0x5	1/32																					
0x6	1/64																					
0x7	1/128																					

Address	Bit	Name	R/W	Default	Description																																							
ADC_BUCK1CFG																																												
0x53	7	ADC_BUCK1CCM	R/W	0x1	0x0 = Disable IOUT, PVIN, VOUT measurements when Buck1 is in CCM 0x1 = Enable IOUT, PVIN, VOUT measurements when Buck1 is in CCM																																							
	6	ADC_BUCK1DCM	R/W	0x0	0x0 = Disable IOUT, PVIN, VOUT measurements when Buck1 is in DCM 0x1 = Enable IOUT, PVIN, VOUT measurements when Buck1 is in DCM																																							
	5	ADC_BUCK1IDLE	R/W	0x0	0x0 = Disable IOUT, PVIN, VOUT measurements when Buck1 is idle (disabled) 0x1 = Enable IOUT, PVIN, VOUT measurements when Buck1 is idle (disabled)																																							
	4	ADC_BUCK1MASKVOUT	R	0x0	0x0 = Do not mask (enable) Buck1 VOUT measurement 0x1 = Mask (disable) Buck1 VOUT measurement																																							
	3	RESERVED	R	0x0																																								
	2:0	ADC_BUCK1IIR	R/W	0x2	<table border="1"> <thead> <tr> <th colspan="4">Buck1 IIR coefficients.</th> </tr> <tr> <th></th> <th>IOUT IIR</th> <th>PVIN IIR</th> <th>VOUT IIR</th> </tr> </thead> <tbody> <tr> <td>0x0</td> <td>1</td> <td>1</td> <td>1</td> </tr> <tr> <td>0x1</td> <td>1/2</td> <td>1</td> <td>1</td> </tr> <tr> <td>0x2</td> <td>1/2</td> <td>1/2</td> <td>1/2</td> </tr> <tr> <td>0x3</td> <td>1/2</td> <td>1/4</td> <td>1/4</td> </tr> <tr> <td>0x4</td> <td>1/4</td> <td>1</td> <td>1</td> </tr> <tr> <td>0x5</td> <td>1/4</td> <td>1/2</td> <td>1/2</td> </tr> <tr> <td>0x6</td> <td>1/4</td> <td>1/4</td> <td>1/4</td> </tr> <tr> <td>0x7</td> <td>1/16</td> <td>1/16</td> <td>1/16</td> </tr> </tbody> </table>	Buck1 IIR coefficients.					IOUT IIR	PVIN IIR	VOUT IIR	0x0	1	1	1	0x1	1/2	1	1	0x2	1/2	1/2	1/2	0x3	1/2	1/4	1/4	0x4	1/4	1	1	0x5	1/4	1/2	1/2	0x6	1/4	1/4	1/4	0x7	1/16	1/16
Buck1 IIR coefficients.																																												
	IOUT IIR	PVIN IIR	VOUT IIR																																									
0x0	1	1	1																																									
0x1	1/2	1	1																																									
0x2	1/2	1/2	1/2																																									
0x3	1/2	1/4	1/4																																									
0x4	1/4	1	1																																									
0x5	1/4	1/2	1/2																																									
0x6	1/4	1/4	1/4																																									
0x7	1/16	1/16	1/16																																									

Address	Bit	Name	R/W	Default	Description																																							
ADC_BUCK2CFG																																												
0x54	7	ADC_BUCK2CCM	R/W	0x1	0x0 = Disable IOUT, PVIN, VOUT measurements when Buck2 is in CCM 0x1 = Enable IOUT, PVIN, VOUT measurements when Buck2 is in CCM																																							
	6	ADC_BUCK2DCM	R/W	0x0	0x0 = Disable IOUT, PVIN, VOUT measurements when Buck2 is in DCM 0x1 = Enable IOUT, PVIN, VOUT measurements when Buck2 is in DCM																																							
	5	ADC_BUCK2IDLE	R/W	0x0	0x0 = Disable IOUT, PVIN, VOUT measurements when Buck2 is idle (disabled) 0x1 = Enable IOUT, PVIN, VOUT measurements when Buck2 is idle (disabled)																																							
	4	ADC_BUCK2MASKVOUT	R	0x0	0x0 = Do not mask (enable) Buck2 VOUT measurement 0x1 = Mask (disable) Buck2 VOUT measurement																																							
	3	RESERVED	R	0x0																																								
	2:0	ADC_BUCK2IIR	R/W	0x2	<table border="1"> <thead> <tr> <th colspan="4">Buck2 IIR coefficients.</th> </tr> <tr> <th></th> <th>IOUT IIR</th> <th>PVIN IIR</th> <th>VOUT IIR</th> </tr> </thead> <tbody> <tr> <td>0x0</td> <td>1</td> <td>1</td> <td>1</td> </tr> <tr> <td>0x1</td> <td>1/2</td> <td>1</td> <td>1</td> </tr> <tr> <td>0x2</td> <td>1/2</td> <td>1/2</td> <td>1/2</td> </tr> <tr> <td>0x3</td> <td>1/2</td> <td>1/4</td> <td>1/4</td> </tr> <tr> <td>0x4</td> <td>1/4</td> <td>1</td> <td>1</td> </tr> <tr> <td>0x5</td> <td>1/4</td> <td>1/2</td> <td>1/2</td> </tr> <tr> <td>0x6</td> <td>1/4</td> <td>1/4</td> <td>1/4</td> </tr> <tr> <td>0x7</td> <td>1/16</td> <td>1/16</td> <td>1/16</td> </tr> </tbody> </table>	Buck2 IIR coefficients.					IOUT IIR	PVIN IIR	VOUT IIR	0x0	1	1	1	0x1	1/2	1	1	0x2	1/2	1/2	1/2	0x3	1/2	1/4	1/4	0x4	1/4	1	1	0x5	1/4	1/2	1/2	0x6	1/4	1/4	1/4	0x7	1/16	1/16
Buck2 IIR coefficients.																																												
	IOUT IIR	PVIN IIR	VOUT IIR																																									
0x0	1	1	1																																									
0x1	1/2	1	1																																									
0x2	1/2	1/2	1/2																																									
0x3	1/2	1/4	1/4																																									
0x4	1/4	1	1																																									
0x5	1/4	1/2	1/2																																									
0x6	1/4	1/4	1/4																																									
0x7	1/16	1/16	1/16																																									

Address	Bit	Name	R/W	Default	Description																																	
ADC_AUXRATECFG																																						
0x55	7	ADC_AUX0IIR16	R/W	0x0	AUX0 input IIR coefficient setting: 0x0 = Coefficient is set to 1. 0x1 = Coefficient is set to 1/16.																																	
	6	ADC_AUX0MASK	R/W	0x1	0x0 = AUX0 input measurement is not masked (Enabled). 0x1 = AUX0 input measurement is masked (Disabled).																																	
	5	ADC_AUX1IIR16	R/W	0x0	AUX1 input IIR coefficient setting: 0x0 = Coefficient is set to 1. 0x1 = Coefficient is set to 1/16.																																	
	4	ADC_AUX1MASK	R/W	0x1	0x0 = AUX1 input measurement is not masked (Enabled). 0x1 = AUX1 input measurement is masked (Disabled).																																	
	3:0	ADC_AUXRATE	R/W	0x0	<table border="1"> <thead> <tr> <th colspan="2">Sampling period for AUX0 and AUX1 inputs.</th> </tr> </thead> <tbody> <tr><td>0x0</td><td>Off</td></tr> <tr><td>0x1</td><td>31.25µs</td></tr> <tr><td>0x2</td><td>62.5µs</td></tr> <tr><td>0x3</td><td>125µs</td></tr> <tr><td>0x4</td><td>250µs</td></tr> <tr><td>0x5</td><td>500µs</td></tr> <tr><td>0x6</td><td>1ms</td></tr> <tr><td>0x7</td><td>2ms</td></tr> <tr><td>0x8</td><td>4ms</td></tr> <tr><td>0x9</td><td>8ms</td></tr> <tr><td>0xA</td><td>16ms</td></tr> <tr><td>0xB</td><td>32ms</td></tr> <tr><td>0xC</td><td>64ms</td></tr> <tr><td>0xD</td><td>128ms</td></tr> <tr><td>0xE</td><td>256ms</td></tr> <tr><td>0xF</td><td>512ms</td></tr> </tbody> </table>	Sampling period for AUX0 and AUX1 inputs.		0x0	Off	0x1	31.25µs	0x2	62.5µs	0x3	125µs	0x4	250µs	0x5	500µs	0x6	1ms	0x7	2ms	0x8	4ms	0x9	8ms	0xA	16ms	0xB	32ms	0xC	64ms	0xD	128ms	0xE	256ms	0xF
Sampling period for AUX0 and AUX1 inputs.																																						
0x0	Off																																					
0x1	31.25µs																																					
0x2	62.5µs																																					
0x3	125µs																																					
0x4	250µs																																					
0x5	500µs																																					
0x6	1ms																																					
0x7	2ms																																					
0x8	4ms																																					
0x9	8ms																																					
0xA	16ms																																					
0xB	32ms																																					
0xC	64ms																																					
0xD	128ms																																					
0xE	256ms																																					
0xF	512ms																																					
FLT_TEMPWARN																																						
0x58	7:0	FLT_TEMPWARN	R/W	0x55	<table border="1"> <thead> <tr> <th colspan="2">Temperature warning threshold (highest)</th> </tr> <tr> <th></th> <th>°C = FLT_TEMPWARN[7:0] (Range 0°C to +255°C)</th> </tr> </thead> <tbody> <tr><td>0x00</td><td>0</td></tr> <tr><td>0x01</td><td>1</td></tr> <tr><td>...</td><td></td></tr> <tr><td>0x7F</td><td>127</td></tr> <tr><td>0x80</td><td>128</td></tr> <tr><td>0x81</td><td>129</td></tr> <tr><td>...</td><td></td></tr> <tr><td>0x8C</td><td>140</td></tr> <tr><td>...</td><td></td></tr> <tr><td>0xFF</td><td>255</td></tr> </tbody> </table>	Temperature warning threshold (highest)			°C = FLT_TEMPWARN[7:0] (Range 0°C to +255°C)	0x00	0	0x01	1	...		0x7F	127	0x80	128	0x81	129	...		0x8C	140	...		0xFF	255									
Temperature warning threshold (highest)																																						
	°C = FLT_TEMPWARN[7:0] (Range 0°C to +255°C)																																					
0x00	0																																					
0x01	1																																					
...																																						
0x7F	127																																					
0x80	128																																					
0x81	129																																					
...																																						
0x8C	140																																					
...																																						
0xFF	255																																					

Address	Bit	Name	R/W	Default	Description																								
FLT_TEMP SHUTDOWN																													
0x59	7:0	FLT_TEMP SHUTDOWN	R/W	0x8C	<table border="1"> <tr> <td colspan="2">Temperature shutdown threshold (highest)</td> </tr> <tr> <td></td> <td>°C = FLT_TEMP SHUTDOWN[7:0] (Range 0°C to +255°C)</td> </tr> <tr> <td>0x00</td> <td>0</td> </tr> <tr> <td>0x01</td> <td>1</td> </tr> <tr> <td>...</td> <td></td> </tr> <tr> <td>0x7F</td> <td>127</td> </tr> <tr> <td>0x80</td> <td>128</td> </tr> <tr> <td>0x81</td> <td>129</td> </tr> <tr> <td>...</td> <td></td> </tr> <tr> <td>0x8C</td> <td>140</td> </tr> <tr> <td>...</td> <td></td> </tr> <tr> <td>0xFF</td> <td>255</td> </tr> </table>	Temperature shutdown threshold (highest)			°C = FLT_TEMP SHUTDOWN[7:0] (Range 0°C to +255°C)	0x00	0	0x01	1	...		0x7F	127	0x80	128	0x81	129	...		0x8C	140	...		0xFF	255
Temperature shutdown threshold (highest)																													
	°C = FLT_TEMP SHUTDOWN[7:0] (Range 0°C to +255°C)																												
0x00	0																												
0x01	1																												
...																													
0x7F	127																												
0x80	128																												
0x81	129																												
...																													
0x8C	140																												
...																													
0xFF	255																												

Address	Bit	Name	R/W	Default	Description																						
FLT_TEMP PHYS																											
0x5A	7:4	FLT_TEMPWARNHYS	R/W	0x5	<table border="1"> <tr> <td colspan="2">Temperature warning hysteresis</td> </tr> <tr> <td></td> <td> Cooling trigger $^{\circ}\text{C} = \text{FLT_TEMPWARN}[7:0] - ((2 \times \text{FLT_TEMPHYS}[7:4]) + 2)$ Note: Cooling trigger must be $\geq 0^{\circ}\text{C}$ </td> </tr> <tr> <td></td> <td>Hysteresis $^{\circ}\text{C}$</td> </tr> <tr> <td>0x0</td> <td>2</td> </tr> <tr> <td>0x1</td> <td>4</td> </tr> <tr> <td>...</td> <td></td> </tr> <tr> <td>0x7</td> <td>16</td> </tr> <tr> <td>0x8</td> <td>18</td> </tr> <tr> <td>0x9</td> <td>20</td> </tr> <tr> <td>...</td> <td></td> </tr> <tr> <td>0xF</td> <td>32</td> </tr> </table>	Temperature warning hysteresis			Cooling trigger $^{\circ}\text{C} = \text{FLT_TEMPWARN}[7:0] - ((2 \times \text{FLT_TEMPHYS}[7:4]) + 2)$ Note: Cooling trigger must be $\geq 0^{\circ}\text{C}$		Hysteresis $^{\circ}\text{C}$	0x0	2	0x1	4	...		0x7	16	0x8	18	0x9	20	...		0xF	32
	Temperature warning hysteresis																										
	Cooling trigger $^{\circ}\text{C} = \text{FLT_TEMPWARN}[7:0] - ((2 \times \text{FLT_TEMPHYS}[7:4]) + 2)$ Note: Cooling trigger must be $\geq 0^{\circ}\text{C}$																										
	Hysteresis $^{\circ}\text{C}$																										
0x0	2																										
0x1	4																										
...																											
0x7	16																										
0x8	18																										
0x9	20																										
...																											
0xF	32																										
	3:0	FLT_TEMP SHUTDOWNHYS	R/W	0xE	<table border="1"> <tr> <td colspan="2">Temperature shutdown hysteresis</td> </tr> <tr> <td></td> <td> Cooling trigger $^{\circ}\text{C} = \text{FLT_TEMP SHUTDOWN}[7:0] - ((2 \times \text{FLT_TEMPHYS}[3:0]) + 2)$ Note: Cooling trigger must be $\geq 0^{\circ}\text{C}$ </td> </tr> <tr> <td></td> <td>Hysteresis $^{\circ}\text{C}$</td> </tr> <tr> <td>0x0</td> <td>4</td> </tr> <tr> <td>0x1</td> <td>8</td> </tr> <tr> <td>...</td> <td></td> </tr> <tr> <td>0x7</td> <td>32</td> </tr> <tr> <td>0x8</td> <td>36</td> </tr> <tr> <td>0x9</td> <td>40</td> </tr> <tr> <td>...</td> <td></td> </tr> <tr> <td>0xF</td> <td>64</td> </tr> </table>	Temperature shutdown hysteresis			Cooling trigger $^{\circ}\text{C} = \text{FLT_TEMP SHUTDOWN}[7:0] - ((2 \times \text{FLT_TEMPHYS}[3:0]) + 2)$ Note: Cooling trigger must be $\geq 0^{\circ}\text{C}$		Hysteresis $^{\circ}\text{C}$	0x0	4	0x1	8	...		0x7	32	0x8	36	0x9	40	...		0xF	64
Temperature shutdown hysteresis																											
	Cooling trigger $^{\circ}\text{C} = \text{FLT_TEMP SHUTDOWN}[7:0] - ((2 \times \text{FLT_TEMPHYS}[3:0]) + 2)$ Note: Cooling trigger must be $\geq 0^{\circ}\text{C}$																										
	Hysteresis $^{\circ}\text{C}$																										
0x0	4																										
0x1	8																										
...																											
0x7	32																										
0x8	36																										
0x9	40																										
...																											
0xF	64																										

Address	Bit	Name	R/W	Default	Description																				
FLT_BUCK1_ISENSEWARN																									
0x5B	7:4	FLT_BUCK1_ISENSEWARNR	R/W	0x5	<table border="1"> <tr> <td colspan="2">Buck1 current sense warning rising threshold</td> </tr> <tr> <td colspan="2">Hysteresis mA = 512mA x (FLT_BUCK1_ISENSEWARNR – FLT_BUCK1_ISENSEWARNF)</td> </tr> <tr> <td colspan="2">Note: Hysteresis must be ≥ 0mA and small enough to ensure that the current goes below the falling threshold.</td> </tr> <tr> <td></td> <td>Current (mA) = 512mA x FLT_BUCK1_ISENSEWARNR</td> </tr> <tr> <td>0x0</td> <td>0</td> </tr> <tr> <td>0x1</td> <td>510</td> </tr> <tr> <td>...</td> <td></td> </tr> <tr> <td>0x4</td> <td>2048</td> </tr> <tr> <td>...</td> <td></td> </tr> <tr> <td>0xF</td> <td>8160</td> </tr> </table>	Buck1 current sense warning rising threshold		Hysteresis mA = 512mA x (FLT_BUCK1_ISENSEWARNR – FLT_BUCK1_ISENSEWARNF)		Note: Hysteresis must be ≥ 0mA and small enough to ensure that the current goes below the falling threshold.			Current (mA) = 512mA x FLT_BUCK1_ISENSEWARNR	0x0	0	0x1	510	...		0x4	2048	...		0xF	8160
	Buck1 current sense warning rising threshold																								
Hysteresis mA = 512mA x (FLT_BUCK1_ISENSEWARNR – FLT_BUCK1_ISENSEWARNF)																									
Note: Hysteresis must be ≥ 0mA and small enough to ensure that the current goes below the falling threshold.																									
	Current (mA) = 512mA x FLT_BUCK1_ISENSEWARNR																								
0x0	0																								
0x1	510																								
...																									
0x4	2048																								
...																									
0xF	8160																								
3:0	FLT_BUCK1_ISENSEWARNF	R/W	0x4	<table border="1"> <tr> <td colspan="2">Buck1 current sense warning falling threshold</td> </tr> <tr> <td></td> <td>Current (mA) = 510mA x FLT_BUCK1_ISENSEWARNF</td> </tr> <tr> <td>0x0</td> <td>0</td> </tr> <tr> <td>0x1</td> <td>510</td> </tr> <tr> <td>...</td> <td></td> </tr> <tr> <td>0x4</td> <td>2048</td> </tr> <tr> <td>...</td> <td></td> </tr> <tr> <td>0xF</td> <td>8160</td> </tr> </table>	Buck1 current sense warning falling threshold			Current (mA) = 510mA x FLT_BUCK1_ISENSEWARNF	0x0	0	0x1	510	...		0x4	2048	...		0xF	8160					
Buck1 current sense warning falling threshold																									
	Current (mA) = 510mA x FLT_BUCK1_ISENSEWARNF																								
0x0	0																								
0x1	510																								
...																									
0x4	2048																								
...																									
0xF	8160																								
FLT_BUCK2_ISENSEWARN																									
0x5C	7:4	FLT_BUCK2_ISENSEWARNR	R/W	0x5	Buck2 current sense warning rising threshold. See “FLT_BUCK1_ISENSEWARN” for decode																				
	3:0	FLT_BUCK2_ISENSEWARNF	R/W	0x4	Buck2 current sense warning falling threshold. See “FLT_BUCK1_ISENSEWARN” for decode																				

Address	Bit	Name	R/W	Default	Description
FLT_BUCK1_ISENSESHUTDN					
0x5D	7:0	FLT_BUCK1_ISENSESHUTDN	R/W	0xE0	Buck1 current sense shutdown threshold (highest) Note: Hysteresis is accomplished by shutting down the Buck and resetting the filtered I _{SENSE} value. Current (mA) = 32mA x FLT_BUCK1_ISENSESHUTDN[7:0]
					0x00 0
					0x01 32 x Nph
					...
					0x7F 4064 x Nph
					0x80 4096 x Nph
					0x81 4128 x Nph
					...
					0xA0 5120 x Nph
					...
					0xFF 8160 x Nph (from ENCF)
FLT_BUCK2_ISENSESHUTDN					
0x5E	7:0	FLT_BUCK2_ISENSESHUTDN	R/W	0xE0	Buck2 current sense shutdown threshold (highest). See "FLT_BUCK1_ISENSESHUTDN" for decode

Address	Bit	Name	R/W	Default	Description						
FLT_MASKTEMP											
0x60	7	FLT_MASKBOOT	R/W	0x0	<table border="1"> <tr> <td colspan="2">Mask IRQ for FLT_BOOT</td> </tr> <tr> <td>0x0</td> <td>IRQ passed to output pin</td> </tr> <tr> <td>0x1</td> <td>IQ masked from output pin</td> </tr> </table>	Mask IRQ for FLT_BOOT		0x0	IRQ passed to output pin	0x1	IQ masked from output pin
	Mask IRQ for FLT_BOOT										
	0x0	IRQ passed to output pin									
	0x1	IQ masked from output pin									
	6:4	Reserved	R	0x0	Reserved						
	3	FLT_MASKTEMPSDR	R/W	0x0	<table border="1"> <tr> <td colspan="2">Mask IRQ for FLT_TEMPSDR</td> </tr> <tr> <td>0x0</td> <td>IRQ passed to output pin</td> </tr> <tr> <td>0x1</td> <td>IRQ masked from output pin</td> </tr> </table>	Mask IRQ for FLT_TEMPSDR		0x0	IRQ passed to output pin	0x1	IRQ masked from output pin
Mask IRQ for FLT_TEMPSDR											
0x0	IRQ passed to output pin										
0x1	IRQ masked from output pin										
2	FLT_MASKTEMPWARNR	R/W	0x0	<table border="1"> <tr> <td colspan="2">Mask IRQ for FLT_TEMPWARNR</td> </tr> <tr> <td>0x0</td> <td>IRQ passed to output pin. Note: FLT_MASKTEMPWARNF must also be set to 0x0 or the IRQ clears itself when the temperature drops below the falling threshold</td> </tr> <tr> <td>0x1</td> <td>IRQ masked from output pin</td> </tr> </table>	Mask IRQ for FLT_TEMPWARNR		0x0	IRQ passed to output pin. Note: FLT_MASKTEMPWARNF must also be set to 0x0 or the IRQ clears itself when the temperature drops below the falling threshold	0x1	IRQ masked from output pin	
Mask IRQ for FLT_TEMPWARNR											
0x0	IRQ passed to output pin. Note: FLT_MASKTEMPWARNF must also be set to 0x0 or the IRQ clears itself when the temperature drops below the falling threshold										
0x1	IRQ masked from output pin										
1	FLT_MASKTEMPWARNF	R/W	0x0	<table border="1"> <tr> <td colspan="2">Mask IRQ for FLT_TEMPWARNF</td> </tr> <tr> <td>0x0</td> <td>IRQ passed to output pin. Note: FLT_MASKTEMPWARNR must also be set to 0x0 or the IRQ clears itself when the temperature goes above the rising threshold</td> </tr> <tr> <td>0x1</td> <td>IRQ masked from output pin</td> </tr> </table>	Mask IRQ for FLT_TEMPWARNF		0x0	IRQ passed to output pin. Note: FLT_MASKTEMPWARNR must also be set to 0x0 or the IRQ clears itself when the temperature goes above the rising threshold	0x1	IRQ masked from output pin	
Mask IRQ for FLT_TEMPWARNF											
0x0	IRQ passed to output pin. Note: FLT_MASKTEMPWARNR must also be set to 0x0 or the IRQ clears itself when the temperature goes above the rising threshold										
0x1	IRQ masked from output pin										
0	FLT_MASKTEMPSDF	R/W	0x0	<table border="1"> <tr> <td colspan="2">Mask IRQ for FLT_TEMP SDF</td> </tr> <tr> <td>0x0</td> <td>IRQ passed to output pin</td> </tr> <tr> <td>0x1</td> <td>IQ masked from output pin</td> </tr> </table>	Mask IRQ for FLT_TEMP SDF		0x0	IRQ passed to output pin	0x1	IQ masked from output pin	
Mask IRQ for FLT_TEMP SDF											
0x0	IRQ passed to output pin										
0x1	IQ masked from output pin										

Address	Bit	Name	R/W	Default	Description						
FLT_MASKBUCK1											
0x61	7	Reserved	R	0x0	Reserved						
	6	FLT_BUCK1_MASKWOC	R/W	0x0	<table border="1"> <tr> <td colspan="2">Mask IRQ for FLT_BUCK1_WOC</td> </tr> <tr> <td>0x0</td> <td>IRQ passed to output pin</td> </tr> <tr> <td>0x1</td> <td>IRQ masked from output pin</td> </tr> </table>	Mask IRQ for FLT_BUCK1_WOC		0x0	IRQ passed to output pin	0x1	IRQ masked from output pin
	Mask IRQ for FLT_BUCK1_WOC										
	0x0	IRQ passed to output pin									
	0x1	IRQ masked from output pin									
	5	FLT_BUCK1_MASKOV	R/W	0x0	<table border="1"> <tr> <td colspan="2">Mask IRQ for FLT_BUCK1_OV</td> </tr> <tr> <td>0x0</td> <td>IRQ passed to output pin</td> </tr> <tr> <td>0x1</td> <td>IRQ masked from output pin</td> </tr> </table>	Mask IRQ for FLT_BUCK1_OV		0x0	IRQ passed to output pin	0x1	IRQ masked from output pin
	Mask IRQ for FLT_BUCK1_OV										
	0x0	IRQ passed to output pin									
0x1	IRQ masked from output pin										
4	FLT_BUCK1_MASKUV	R/W	0x0	<table border="1"> <tr> <td colspan="2">Mask IRQ for FLT_BUCK1_UV</td> </tr> <tr> <td>0x0</td> <td>IRQ passed to output pin</td> </tr> <tr> <td>0x1</td> <td>IRQ masked from output pin</td> </tr> </table>	Mask IRQ for FLT_BUCK1_UV		0x0	IRQ passed to output pin	0x1	IRQ masked from output pin	
Mask IRQ for FLT_BUCK1_UV											
0x0	IRQ passed to output pin										
0x1	IRQ masked from output pin										
3	FLT_BUCK1_MASKOCSDR	R/W	0x0	<table border="1"> <tr> <td colspan="2">Mask IRQ for FLT_BUCK1_OCSDR</td> </tr> <tr> <td>0x0</td> <td>IRQ passed to output pin</td> </tr> <tr> <td>0x1</td> <td>IRQ masked from output pin</td> </tr> </table>	Mask IRQ for FLT_BUCK1_OCSDR		0x0	IRQ passed to output pin	0x1	IRQ masked from output pin	
Mask IRQ for FLT_BUCK1_OCSDR											
0x0	IRQ passed to output pin										
0x1	IRQ masked from output pin										
2	FLT_BUCK1_MASKOCWR	R/W	0x0	<table border="1"> <tr> <td colspan="2">Mask IRQ for FLT_BUCK1_OCWR</td> </tr> <tr> <td>0x0</td> <td>IRQ passed to output pin. Note: FLT_MASKOCWF must also be set to 0x0 or the IRQ clears itself when the current drops below the falling threshold</td> </tr> <tr> <td>0x1</td> <td>IRQ masked from output pin</td> </tr> </table>	Mask IRQ for FLT_BUCK1_OCWR		0x0	IRQ passed to output pin. Note: FLT_MASKOCWF must also be set to 0x0 or the IRQ clears itself when the current drops below the falling threshold	0x1	IRQ masked from output pin	
Mask IRQ for FLT_BUCK1_OCWR											
0x0	IRQ passed to output pin. Note: FLT_MASKOCWF must also be set to 0x0 or the IRQ clears itself when the current drops below the falling threshold										
0x1	IRQ masked from output pin										
1	FLT_BUCK1_MASKOCWF	R/W	0x0	<table border="1"> <tr> <td colspan="2">Mask IRQ for FLT_BUCK1_OCWF</td> </tr> <tr> <td>0x0</td> <td>IRQ passed to output pin</td> </tr> <tr> <td>0x1</td> <td>IRQ masked from output pin</td> </tr> </table>	Mask IRQ for FLT_BUCK1_OCWF		0x0	IRQ passed to output pin	0x1	IRQ masked from output pin	
Mask IRQ for FLT_BUCK1_OCWF											
0x0	IRQ passed to output pin										
0x1	IRQ masked from output pin										
0	Reserved	R	0x0	Reserved							

Address	Bit	Name	R/W	Default	Description											
FLT_MASKBUCK2																
0x62	7	FLT_BUCK2_MASKRSVD1	R	0x0	IRQ masks for Buck2. See " FLT_MASKBUCK1 " for description											
	6	FLT_BUCK2_MASKWOC	R/W	0x0												
	5	FLT_BUCK2_MASKOV	R/W	0x0												
	4	FLT_BUCK2_MASKUV	R/W	0x0												
	3	FLT_BUCK2_MASKOCSDR	R/W	0x0												
	2	FLT_BUCK2_MASKOCWR	R/W	0x0												
	1	FLT_BUCK2_MASKOCWF	R/W	0x0												
	0	FLT_BUCK2_MASKRSVD2	R	0x0												
FLT_OT_CTRL																
0x63	7:2	Reserved	R	0x0	Reserved											
	1:0	FLT_CTRLLOT	R/W	0x3		<table border="1"> <thead> <tr> <th>Bit</th> <th colspan="2">Over-Temperature (OT) fault response</th> </tr> </thead> <tbody> <tr> <td rowspan="2"><0></td> <td>0x0</td> <td>Buck1 shuts down on Over-Temperature (OT) detection faults, measured by the ADC. (FLT_TEMPSTR[0] = 0x0 → 0x1) Buck is re-enabled when the temperature measured by the ADC drops below the hysteresis level (FLT_TEMPSTR[0] = 0x1 → 0x0)</td> </tr> <tr> <td>0x1</td> <td>Buck1 does not shut down on Over-Temperature (OT) faults</td> </tr> <tr> <td rowspan="2"><0></td> <td>0x0</td> <td rowspan="2">Buck2 OT control. See description above.</td> </tr> <tr> <td>0x1</td> </tr> </tbody> </table>	Bit	Over-Temperature (OT) fault response		<0>	0x0	Buck1 shuts down on Over-Temperature (OT) detection faults, measured by the ADC. (FLT_TEMPSTR[0] = 0x0 → 0x1) Buck is re-enabled when the temperature measured by the ADC drops below the hysteresis level (FLT_TEMPSTR[0] = 0x1 → 0x0)	0x1	Buck1 does not shut down on Over-Temperature (OT) faults	<0>	0x0
Bit	Over-Temperature (OT) fault response															
<0>	0x0	Buck1 shuts down on Over-Temperature (OT) detection faults, measured by the ADC. (FLT_TEMPSTR[0] = 0x0 → 0x1) Buck is re-enabled when the temperature measured by the ADC drops below the hysteresis level (FLT_TEMPSTR[0] = 0x1 → 0x0)														
	0x1	Buck1 does not shut down on Over-Temperature (OT) faults														
<0>	0x0	Buck2 OT control. See description above.														
	0x1															

Address	Bit	Name	R/W	Default	Description						
FLT_BUCK1_CTRL											
0x64	7:5	Reserved	R	0x0	Reserved						
	4	FLT_BUCK1_CTRLLOC	R/W	0x0	<table border="1"> <thead> <tr> <th colspan="2">Overcurrent (OC) fault response</th> </tr> </thead> <tbody> <tr> <td>0x0</td> <td>The buck shuts down on Overcurrent (OC) detection faults, measured by the ADC (FLT_OCSDR[0] = 0x0 → 0x1). The overcurrent detection fault state can only be cleared by cycling the EN pin or by issuing a soft-reset command. (IO_SOFTRESET[0] = 0x1)</td> </tr> <tr> <td>0x1</td> <td>The buck does not shut down on Overcurrent (OC) detection faults, measured by the ADC. (FLT_OCSDR[0] = 0x0 → 0x1)</td> </tr> </tbody> </table>	Overcurrent (OC) fault response		0x0	The buck shuts down on Overcurrent (OC) detection faults, measured by the ADC (FLT_OCSDR[0] = 0x0 → 0x1). The overcurrent detection fault state can only be cleared by cycling the EN pin or by issuing a soft-reset command. (IO_SOFTRESET[0] = 0x1)	0x1	The buck does not shut down on Overcurrent (OC) detection faults, measured by the ADC. (FLT_OCSDR[0] = 0x0 → 0x1)
	Overcurrent (OC) fault response										
	0x0	The buck shuts down on Overcurrent (OC) detection faults, measured by the ADC (FLT_OCSDR[0] = 0x0 → 0x1). The overcurrent detection fault state can only be cleared by cycling the EN pin or by issuing a soft-reset command. (IO_SOFTRESET[0] = 0x1)									
0x1	The buck does not shut down on Overcurrent (OC) detection faults, measured by the ADC. (FLT_OCSDR[0] = 0x0 → 0x1)										
3	FLT_BUCK1_CTRLWOC	R/W	0x0	<table border="1"> <thead> <tr> <th colspan="2">Way Overcurrent (WOC) fault response</th> </tr> </thead> <tbody> <tr> <td>0x0</td> <td>The buck shuts down on Way Overcurrent (WOC) detection faults, measured by the buck (FLT_WOC[0] = 0x0 → 0x1). The buck is quickly re-enabled using the same register configuration. If the fault still exists, the buck shuts down (and restarts) until the fault is removed</td> </tr> <tr> <td>0x1</td> <td>The buck does not shut down on Way Overcurrent (WOC) detection faults, measured by the buck (FLT_WOC[0] = 0x0 → 0x1)</td> </tr> </tbody> </table>	Way Overcurrent (WOC) fault response		0x0	The buck shuts down on Way Overcurrent (WOC) detection faults, measured by the buck (FLT_WOC[0] = 0x0 → 0x1). The buck is quickly re-enabled using the same register configuration. If the fault still exists, the buck shuts down (and restarts) until the fault is removed	0x1	The buck does not shut down on Way Overcurrent (WOC) detection faults, measured by the buck (FLT_WOC[0] = 0x0 → 0x1)	
Way Overcurrent (WOC) fault response											
0x0	The buck shuts down on Way Overcurrent (WOC) detection faults, measured by the buck (FLT_WOC[0] = 0x0 → 0x1). The buck is quickly re-enabled using the same register configuration. If the fault still exists, the buck shuts down (and restarts) until the fault is removed										
0x1	The buck does not shut down on Way Overcurrent (WOC) detection faults, measured by the buck (FLT_WOC[0] = 0x0 → 0x1)										
2:1	FLT_BUCK1_CTRLLOV	R/W	0x2	<table border="1"> <thead> <tr> <th colspan="2">Overvoltage (OV) fault response</th> </tr> </thead> <tbody> <tr> <td>0x0/ 0x2</td> <td>The buck crowbars the output driver (turns on the NMOS) on Overvoltage (OV) detection faults, measured by the buck (FLT_OV[0] = 0x0 → 0x1). After 32 to 64 μs, the buck shuts down and exits crowbar mode. The buck is quickly re-enabled using the same configuration. If the fault still exists the buck shuts down (and restarts) until the fault is removed</td> </tr> <tr> <td>0x1/ 0x3</td> <td>The buck does not shut down on Overvoltage (OV) detection faults, measured by the Buck (FLT_OV[0] = 0x0 → 0x1)</td> </tr> </tbody> </table>	Overvoltage (OV) fault response		0x0/ 0x2	The buck crowbars the output driver (turns on the NMOS) on Overvoltage (OV) detection faults, measured by the buck (FLT_OV[0] = 0x0 → 0x1). After 32 to 64 μs, the buck shuts down and exits crowbar mode. The buck is quickly re-enabled using the same configuration. If the fault still exists the buck shuts down (and restarts) until the fault is removed	0x1/ 0x3	The buck does not shut down on Overvoltage (OV) detection faults, measured by the Buck (FLT_OV[0] = 0x0 → 0x1)	
Overvoltage (OV) fault response											
0x0/ 0x2	The buck crowbars the output driver (turns on the NMOS) on Overvoltage (OV) detection faults, measured by the buck (FLT_OV[0] = 0x0 → 0x1). After 32 to 64 μs, the buck shuts down and exits crowbar mode. The buck is quickly re-enabled using the same configuration. If the fault still exists the buck shuts down (and restarts) until the fault is removed										
0x1/ 0x3	The buck does not shut down on Overvoltage (OV) detection faults, measured by the Buck (FLT_OV[0] = 0x0 → 0x1)										
0	0	FLT_BUCK1_CTRLUV	R/W	0x0	<table border="1"> <thead> <tr> <th colspan="2">Undervoltage (UV) Fault Response</th> </tr> </thead> <tbody> <tr> <td>0x0</td> <td>Buck will shut down on Undervoltage (UV) detection faults, measured by the buck. (FLT_UV[0] = 0x0 → 0x1)</td> </tr> <tr> <td>0x1</td> <td>Buck will not shut down on Undervoltage (UV) detection faults, measured by the buck. (FLT_UV[0] = 0x0 → 0x1)</td> </tr> </tbody> </table>	Undervoltage (UV) Fault Response		0x0	Buck will shut down on Undervoltage (UV) detection faults, measured by the buck. (FLT_UV[0] = 0x0 → 0x1)	0x1	Buck will not shut down on Undervoltage (UV) detection faults, measured by the buck. (FLT_UV[0] = 0x0 → 0x1)
	Undervoltage (UV) Fault Response										
	0x0	Buck will shut down on Undervoltage (UV) detection faults, measured by the buck. (FLT_UV[0] = 0x0 → 0x1)									
0x1	Buck will not shut down on Undervoltage (UV) detection faults, measured by the buck. (FLT_UV[0] = 0x0 → 0x1)										
FLT_BUCK2_CTRL											
0x65	7:5	FLT_BUCK2_CTRLRSVD	R	0x0	Buck2 fault control. See " FLT_BUCK1_CTRL " for description						
	4	FLT_BUCK2_CTRLLOC	R/W	0x0							
	3	FLT_BUCK2_CTRLWOC	R/W	0x0							
	2:1	FLT_BUCK2_CTRLLOV	R/W	0x2							
	0	FLT_BUCK2_CTRLUV	R/W	0x0							

Address	Bit	Name	R/W	Default	Description															
BUCK1_EA2																				
0x66	7:6	BUCK1_VOUTFBDIV	R/W	0x0	<table border="1"> <thead> <tr> <th>BUCK1_VOUTFBDIV[1:0]</th> <th>Feedback Divider Ratio (FBDIV)</th> <th>Maximum V_{OUT} Setting</th> </tr> </thead> <tbody> <tr> <td>0x0</td> <td>1.0</td> <td>1.2328V</td> </tr> <tr> <td>0x1</td> <td>0.8</td> <td>1.5410V</td> </tr> <tr> <td>0x2</td> <td>0.6</td> <td>2.0547V</td> </tr> <tr> <td>0x3</td> <td>Reserved</td> <td>Reserved</td> </tr> </tbody> </table>	BUCK1_VOUTFBDIV[1:0]	Feedback Divider Ratio (FBDIV)	Maximum V _{OUT} Setting	0x0	1.0	1.2328V	0x1	0.8	1.5410V	0x2	0.6	2.0547V	0x3	Reserved	Reserved
					BUCK1_VOUTFBDIV[1:0]	Feedback Divider Ratio (FBDIV)	Maximum V _{OUT} Setting													
					0x0	1.0	1.2328V													
					0x1	0.8	1.5410V													
	0x2	0.6	2.0547V																	
0x3	Reserved	Reserved																		
Reserved	R	0x1B	Reserved																	
BUCK1_DCM																				
0x69	7:3	Reserved	R	0x0	Reserved															
	2	BUCK1_FCCM	R/W	0x0	<table border="1"> <thead> <tr> <th colspan="2">Forced Continuous Conduction Mode (CCM)</th> </tr> </thead> <tbody> <tr> <td>0x0</td> <td>Discontinuous Conduction Mode (DCM) allowed when load reaches 0A</td> </tr> <tr> <td>0x1</td> <td>Always operates in CCM</td> </tr> </tbody> </table>	Forced Continuous Conduction Mode (CCM)		0x0	Discontinuous Conduction Mode (DCM) allowed when load reaches 0A	0x1	Always operates in CCM									
					Forced Continuous Conduction Mode (CCM)															
0x0	Discontinuous Conduction Mode (DCM) allowed when load reaches 0A																			
0x1	Always operates in CCM																			
1:0	Reserved	R/W	0x0	Reserved																
BUCK1_CFG3																				
0x6A	7:6	BUCK1_FSEL	R/W	0x2	<table border="1"> <thead> <tr> <th colspan="2">Buck's steady-state switching frequency</th> </tr> </thead> <tbody> <tr> <td>0x0</td> <td>2MHz</td> </tr> <tr> <td>0x1</td> <td>3MHz</td> </tr> <tr> <td>0x2</td> <td>4MHz</td> </tr> <tr> <td>0x3</td> <td>Reserved</td> </tr> </tbody> </table>	Buck's steady-state switching frequency		0x0	2MHz	0x1	3MHz	0x2	4MHz	0x3	Reserved					
					Buck's steady-state switching frequency															
					0x0	2MHz														
0x1					3MHz															
0x2	4MHz																			
0x3	Reserved																			
5:4	Reserved	R	0x2	Reserved																
3:0	Reserved	R	0x1 0x2 0x3	Reserved Note: Default = 0x1 for 2+2, 0x2 for 3+1, and 0x3 for 4+0 configurations																

Address	Bit	Name	R/W	Default	Description																																												
BUCK1_PROTCFG																																																	
0x6E	7:4	Reserved	R	0x0	Reserved																																												
	3	BUCK1_ENUVOV	R/W	0x1	<table border="1"> <tr> <td colspan="2">Undervoltage (UV) and Overvoltage (OV) comparators of V_{OUT}</td> </tr> <tr> <td>0x0</td> <td>Disabled</td> </tr> <tr> <td>0x1</td> <td>Enabled Note: When the buck is programmed to 0V and the DAC[9:0] value reaches 0x000, the Overvoltage (OV) signal out of the buck is held low even though the buck output voltage may be higher than the Overvoltage (OV) threshold.</td> </tr> </table>	Undervoltage (UV) and Overvoltage (OV) comparators of V_{OUT}		0x0	Disabled	0x1	Enabled Note: When the buck is programmed to 0V and the DAC[9:0] value reaches 0x000, the Overvoltage (OV) signal out of the buck is held low even though the buck output voltage may be higher than the Overvoltage (OV) threshold.																																						
	Undervoltage (UV) and Overvoltage (OV) comparators of V_{OUT}																																																
0x0	Disabled																																																
0x1	Enabled Note: When the buck is programmed to 0V and the DAC[9:0] value reaches 0x000, the Overvoltage (OV) signal out of the buck is held low even though the buck output voltage may be higher than the Overvoltage (OV) threshold.																																																
2	BUCK1_OVNOHYS	R/W	0x1	<table border="1"> <tr> <td colspan="2">Hysteresis on the Overvoltage (OV) comparator of V_{OUT}</td> </tr> <tr> <td>0x0</td> <td>Hysteresis enabled. OV flag goes low when V_{OUT} decreases below the DAC target</td> </tr> <tr> <td>0x1</td> <td>Hysteresis disabled. OV flag goes low when V_{OUT} goes below DAC target + offset (offset is set by BUCK1_UVOVTH[1:0]).</td> </tr> </table>	Hysteresis on the Overvoltage (OV) comparator of V_{OUT}		0x0	Hysteresis enabled. OV flag goes low when V_{OUT} decreases below the DAC target	0x1	Hysteresis disabled. OV flag goes low when V_{OUT} goes below DAC target + offset (offset is set by BUCK1_UVOVTH[1:0]).																																							
Hysteresis on the Overvoltage (OV) comparator of V_{OUT}																																																	
0x0	Hysteresis enabled. OV flag goes low when V_{OUT} decreases below the DAC target																																																
0x1	Hysteresis disabled. OV flag goes low when V_{OUT} goes below DAC target + offset (offset is set by BUCK1_UVOVTH[1:0]).																																																
1:0	BUCK1_UVOVTH	R/W	0x2	<table border="1"> <tr> <td colspan="2">UV and OV trip thresholds of V_{OUT}</td> </tr> <tr> <td>0x0</td> <td>±150mV window around DAC target</td> </tr> <tr> <td>0x1</td> <td>±200mV window around DAC target</td> </tr> <tr> <td>0x2</td> <td>±250mV window around DAC target</td> </tr> <tr> <td>0x3</td> <td>±300mV window around DAC target</td> </tr> </table>	UV and OV trip thresholds of V_{OUT}		0x0	±150mV window around DAC target	0x1	±200mV window around DAC target	0x2	±250mV window around DAC target	0x3	±300mV window around DAC target																																			
UV and OV trip thresholds of V_{OUT}																																																	
0x0	±150mV window around DAC target																																																
0x1	±200mV window around DAC target																																																
0x2	±250mV window around DAC target																																																
0x3	±300mV window around DAC target																																																
BUCK1_DVS0CFG1																																																	
0x72	7:0	BUCK1_DVS0VOUT92	R/W	Trim to 0.6V	<table border="1"> <tr> <td colspan="4">Upper eight bits of a 10-bit DAC[9:0] value to generate V_{OUT} for DVS Configuration 0.</td> </tr> <tr> <td colspan="4">Note: V_{OUT} must be programmed above 0.3V. FBDIV is set by factory OTP to 1x, 0.8x, 0.6x. Refer to formula in (EQ. 1) on page 24.</td> </tr> <tr> <td>FBDIV</td> <td>1.0</td> <td>0.8</td> <td>0.6</td> </tr> <tr> <td>DAC</td> <td>V_{OUT} (V)</td> <td>V_{OUT} (V)</td> <td>V_{OUT} (V)</td> </tr> <tr> <td>0x000</td> <td>0.0000</td> <td>0.0000</td> <td>0.0000</td> </tr> <tr> <td>0x001</td> <td>0.0012</td> <td>0.0015</td> <td>0.0020</td> </tr> <tr> <td>...</td> <td></td> <td></td> <td></td> </tr> <tr> <td>0x200</td> <td>0.6170</td> <td>0.7713</td> <td>1.0283</td> </tr> <tr> <td>0x201</td> <td>0.6182</td> <td>0.7728</td> <td>1.0303</td> </tr> <tr> <td>...</td> <td></td> <td></td> <td></td> </tr> <tr> <td>0x3E5</td> <td>1.2015</td> <td>1.5018</td> <td>2.0024</td> </tr> </table>	Upper eight bits of a 10-bit DAC[9:0] value to generate V_{OUT} for DVS Configuration 0.				Note: V_{OUT} must be programmed above 0.3V. FBDIV is set by factory OTP to 1x, 0.8x, 0.6x. Refer to formula in (EQ. 1) on page 24 .				FBDIV	1.0	0.8	0.6	DAC	V_{OUT} (V)	V_{OUT} (V)	V_{OUT} (V)	0x000	0.0000	0.0000	0.0000	0x001	0.0012	0.0015	0.0020	...				0x200	0.6170	0.7713	1.0283	0x201	0.6182	0.7728	1.0303	...				0x3E5	1.2015	1.5018	2.0024
Upper eight bits of a 10-bit DAC[9:0] value to generate V_{OUT} for DVS Configuration 0.																																																	
Note: V_{OUT} must be programmed above 0.3V. FBDIV is set by factory OTP to 1x, 0.8x, 0.6x. Refer to formula in (EQ. 1) on page 24 .																																																	
FBDIV	1.0	0.8	0.6																																														
DAC	V_{OUT} (V)	V_{OUT} (V)	V_{OUT} (V)																																														
0x000	0.0000	0.0000	0.0000																																														
0x001	0.0012	0.0015	0.0020																																														
...																																																	
0x200	0.6170	0.7713	1.0283																																														
0x201	0.6182	0.7728	1.0303																																														
...																																																	
0x3E5	1.2015	1.5018	2.0024																																														

Address	Bit	Name	R/W	Default	Description						
BUCK1_DVS0CFG0											
0x73	7:6	BUCK1_DVS0VOUT10	R/W	Trim to 0.6V	Lower two bits of a 10-bit DAC[9:0] value to generate V_{OUT} for DVS Configuration 0. Note: When DVS Configuration 0 is selected (from pins or registers) any write to BUCK1_DVS0CFG0 causes DVS ramping to occur						
	5	BUCK1_DVS0DECAY	R/W	0x0		<table border="1"> <tr> <td colspan="2">Buck DECAY for DVS configuration 0</td> </tr> <tr> <td>0x0</td> <td>Active pull-down, decay determined by selected slew rate</td> </tr> <tr> <td>0x1</td> <td>Decay mode (load determines slew rate)</td> </tr> </table>	Buck DECAY for DVS configuration 0		0x0	Active pull-down, decay determined by selected slew rate	0x1
	Buck DECAY for DVS configuration 0										
0x0	Active pull-down, decay determined by selected slew rate										
0x1	Decay mode (load determines slew rate)										
4:0	Reserved	R	0x0	Reserved bits							
BUCK1_DVS1CFG1											
0x74	7:0	BUCK1_DVS1VOUT92	R/W	0xBF	Buck1 DVS1 Configuration 1. See " BUCK1_DVS0CFG1 " for description						
BUCK1_DVS1CFG0											
0x75	7:6	BUCK1_DVS1VOUT10	R/W	0x3	Buck1 DVS1 Configuration 0. See " BUCK1_DVS0CFG0 " for description						
	5	BUCK1_DVS1DECAY	R/W	0x0							
	4:0	BUCK1_DVS1RSVD	R	0x0							
BUCK1_DVS2CFG1											
0x76	7:0	BUCK1_DVS2VOUT92	R/W	0x58	Buck1 DVS2 Configuration 1. See " BUCK1_DVS0CFG1 " for description						
BUCK1_DVS2CFG0											
0x77	7:6	BUCK1_DVS2VOUT10	R/W	0x0	Buck1 DVS2 Configuration 0. See " BUCK1_DVS0CFG0 " for description						
	5	BUCK1_DVS2DECAY	R/W	0x0							
	4:0	BUCK1_DVS2RSVD	R	0x0							
BUCK1_DVS3CFG1											
0x78	7:0	BUCK1_DVS3VOUT92	R/W	0x00	Buck1 DVS3 Configuration 1. See " BUCK1_DVS0CFG1 " for description						
BUCK1_DVS3CFG0											
0x79	7:6	BUCK1_DVS3VOUT10	R/W	0x0	Buck1 DVS3 Configuration 0. See " BUCK1_DVS0CFG0 " for description						
	5	BUCK1_DVS3DECAY	R/W	0x0							
	4:0	BUCK1_DVS3RSVD	R	0x0							
BUCK1_VOUTMAXMSB											
0x7A	7:2	Reserved	R	0x00	Reserved						
	1:0	BUCK1_VOUTMAX98	R/W	0x3		<table border="1"> <tr> <td colspan="2">Upper two bits of V_{OUT} maximum programming limit</td> </tr> <tr> <td colspan="2">Data format is same as BUCK1_DVS[3:0]VOUT[9:0]</td> </tr> </table>	Upper two bits of V_{OUT} maximum programming limit		Data format is same as BUCK1_DVS[3:0]VOUT[9:0]		
Upper two bits of V_{OUT} maximum programming limit											
Data format is same as BUCK1_DVS[3:0]VOUT[9:0]											
BUCK1_VOUTMAXLSB											
0x7B	7:0	BUCK1_VOUTMAXLSB	R/W	0xFF	<table border="1"> <tr> <td colspan="2">Lower eight bits of V_{OUT} maximum programming limit</td> </tr> <tr> <td colspan="2">Data format is same as BUCK1_DVS[3:0]VOUT[9:0]</td> </tr> </table>	Lower eight bits of V_{OUT} maximum programming limit		Data format is same as BUCK1_DVS[3:0]VOUT[9:0]			
Lower eight bits of V_{OUT} maximum programming limit											
Data format is same as BUCK1_DVS[3:0]VOUT[9:0]											

Address	Bit	Name	R/W	Default	Description		
BUCK1_DVSCFG							
0x7C	7:5	Reserved	R	0x0	Reserved		
	4	BUCK1_PGOODDAC0V	R/W	0x0	Power-Good state when Buck1 DAC is set to 0V		
					0x0	BUCK1_PGOOD is set low when the DAC is set to 0V	
0x1	BUCK1_PGOOD is allowed to stay high when the DAC is set to 0V						
0x7C	3:2	BUCK1_PGOODDELAY	R/W	0x0	Delay before the PGOOD signal is set (no delay when cleared)		
						Delay = BUCK1_PGOODDELAY[1:0] /32kHz (µs)	Number of Clocks
					0x0	0	0
					0x1	125	4
					0x2	375	12
0x3	1000	32					
0x7C	1:0	BUCK1_DVSPIN_CTRL	R/W	0x0	Register determines whether Buck1 follows global DVS pins		
					Bit<0>		
					0x0	BUCK1_DVSSELECT[0] does NOT follow DVS_PIN0.	
					0x1	BUCK1_DVSSELECT[0] mirrors DVS_PIN0.	
					Bit<1>		
					0x0	BUCK1_DVSSELECT[1] does NOT follow DVS_PIN1.	
0x1	BUCK1_DVSSELECT[1] mirrors DVS_PIN1.						
See "Dynamic Voltage Scaling (DVS)" on page 23 for more information about using this register. This register is valid only in PINMODE 0x4 and 0xE							

Address	Bit	Name	R/W	Default	Description																												
BUCK1_DVSSEL																																	
0x7D	7:3	Reserved	R	0x00	Reserved																												
	2	BUCK1_DVSCTRL	R/W	0x0	<table border="1"> <tr> <td colspan="3">BUCK1 DVS control</td> </tr> <tr> <td>0x0</td> <td colspan="2">Use BUCK1_DVSSELECT[1:0] to select the active DVS configuration</td> </tr> <tr> <td>0x1</td> <td colspan="2">Use DVS pin(s) to control the DVS selection</td> </tr> <tr> <td></td> <td>DVS_1</td> <td>DVS_0</td> <td>Active DVS configuration registers</td> </tr> <tr> <td></td> <td>0</td> <td>0</td> <td>Use DVS0 voltage setting</td> </tr> <tr> <td></td> <td>0</td> <td>1</td> <td>Use DVS1 voltage setting</td> </tr> <tr> <td></td> <td>1</td> <td>0</td> <td>Use DVS2 voltage setting</td> </tr> <tr> <td></td> <td>1</td> <td>1</td> <td>Use DVS3 voltage setting</td> </tr> </table> <p>See “Dynamic Voltage Scaling (DVS)” on page 23 for more information about using this register</p>	BUCK1 DVS control			0x0	Use BUCK1_DVSSELECT[1:0] to select the active DVS configuration		0x1	Use DVS pin(s) to control the DVS selection			DVS_1	DVS_0	Active DVS configuration registers		0	0	Use DVS0 voltage setting		0	1	Use DVS1 voltage setting		1	0	Use DVS2 voltage setting		1	1
BUCK1 DVS control																																	
0x0	Use BUCK1_DVSSELECT[1:0] to select the active DVS configuration																																
0x1	Use DVS pin(s) to control the DVS selection																																
	DVS_1	DVS_0	Active DVS configuration registers																														
	0	0	Use DVS0 voltage setting																														
	0	1	Use DVS1 voltage setting																														
	1	0	Use DVS2 voltage setting																														
	1	1	Use DVS3 voltage setting																														
	1:0	BUCK1_DVSSELECT	R/W	0x0	<table border="1"> <tr> <td colspan="2">BUCK1 DVS selection</td> </tr> <tr> <td>0x0</td> <td>Use DVS0 voltage setting</td> </tr> <tr> <td>0x1</td> <td>Use DVS1 voltage setting</td> </tr> <tr> <td>0x2</td> <td>Use DVS2 voltage setting</td> </tr> <tr> <td>0x3</td> <td>Use DVS3 voltage setting</td> </tr> </table> <p>Note: When BUCK1_DVSCTRL[0] = 0x0 any write to the register BUCK1_DVSSEL causes a DVS ramping event to occur.</p> <p>See “Dynamic Voltage Scaling (DVS)” on page 23 for more information about using this register</p>	BUCK1 DVS selection		0x0	Use DVS0 voltage setting	0x1	Use DVS1 voltage setting	0x2	Use DVS2 voltage setting	0x3	Use DVS3 voltage setting																		
BUCK1 DVS selection																																	
0x0	Use DVS0 voltage setting																																
0x1	Use DVS1 voltage setting																																
0x2	Use DVS2 voltage setting																																
0x3	Use DVS3 voltage setting																																

Address	Bit	Name	R/W	Default	Description				
BUCK1_RSPCFG1									
0x7E	7	BUCK1_RSPCFG1RSVD1	R	0x0	Reserved				
	6:4	BUCK1_RSPUP	R/W	0x7	This slew rate is used when the current voltage is less than the target voltage. V_{OUT} ramp slew rate. RSP = BUCK1_RSPUP[1:0], ramp speed FBDIV = BUCK1_VOUTFBDIV[1:0] = (1.0, 0.8, 0.6) Slow = BUCK1_RSPUP[2] = 0 Fast = BUCK1_RSPUP[2] = 1				
								V_{OUT} Ramp Speed mV/μs	
						RSP	FBDIV	Fast	Slow
						0x0	1.0	12	3
0x1	1.0	24	6						
0x2	1.0	57.6	14.4						
0x3	1.0	115.2	28.8						
				V_{OUT} Ramp Speed mV/μs					
		RSP	FBDIV	Fast	Slow				
		0x0 0x2	0.8/0.6	12	3				
		0x1 0x3	0.8/0.6	24	6				
	3	Reserved	R	0x0	Reserved				
	2:0	BUCK1_RSPDN	R/W	0x3	This slew rate is used when the current voltage is greater than the target voltage. See BUCK1_RSPUP for decode information				

Address	Bit	Name	R/W	Default	Description																																																												
BUCK1_RSPCFG0																																																																	
0x7F	7	Reserved	R	0x0	Reserved																																																												
	6:4	BUCK1_RSPPUP	R/W	0x7	This slew rate is used when the current voltage is 0V and the target is greater than 0V. <table border="1"> <tr> <td colspan="4">V_{OUT} Ramp Slew Rate</td> </tr> <tr> <td colspan="4">RSP = BUCK1_RSPPUP[1:0], ramp speed</td> </tr> <tr> <td colspan="4">FBDIV = BUCK1_VOUTFBDIV[1:0] = (1.0, 0.8, 0.6)</td> </tr> <tr> <td colspan="4">Slow = BUCK1_RSPPUP[2] = 0</td> </tr> <tr> <td colspan="4">Fast = BUCK1_RSPPUP[2] = 1</td> </tr> <tr> <td>RSP</td> <td>FBDIV</td> <td colspan="2">V_{OUT} Ramp Speed mV/μs</td> </tr> <tr> <td></td> <td></td> <td>Fast</td> <td>Slow</td> </tr> <tr> <td>0x0</td> <td>1.0</td> <td>6</td> <td>1.2</td> </tr> <tr> <td>0x1</td> <td>1.0</td> <td>12</td> <td>3</td> </tr> <tr> <td>0x2</td> <td>1.0</td> <td>28.8</td> <td>7.2</td> </tr> <tr> <td>0x3</td> <td>1.0</td> <td>57.6</td> <td>14.4</td> </tr> <tr> <td>RSP</td> <td>FBDIV</td> <td colspan="2">V_{OUT} Ramp Speed mV/μs</td> </tr> <tr> <td></td> <td></td> <td>Fast</td> <td>Slow</td> </tr> <tr> <td>0x0 0x2</td> <td>0.8/0.6</td> <td>12</td> <td>3</td> </tr> <tr> <td>0x1 0x3</td> <td>0.8/0.6</td> <td>24</td> <td>6</td> </tr> </table>	V _{OUT} Ramp Slew Rate				RSP = BUCK1_RSPPUP[1:0], ramp speed				FBDIV = BUCK1_VOUTFBDIV[1:0] = (1.0, 0.8, 0.6)				Slow = BUCK1_RSPPUP[2] = 0				Fast = BUCK1_RSPPUP[2] = 1				RSP	FBDIV	V_{OUT} Ramp Speed mV/μs				Fast	Slow	0x0	1.0	6	1.2	0x1	1.0	12	3	0x2	1.0	28.8	7.2	0x3	1.0	57.6	14.4	RSP	FBDIV	V_{OUT} Ramp Speed mV/μs				Fast	Slow	0x0 0x2	0.8/0.6	12	3	0x1 0x3	0.8/0.6	24	6
	V _{OUT} Ramp Slew Rate																																																																
	RSP = BUCK1_RSPPUP[1:0], ramp speed																																																																
FBDIV = BUCK1_VOUTFBDIV[1:0] = (1.0, 0.8, 0.6)																																																																	
Slow = BUCK1_RSPPUP[2] = 0																																																																	
Fast = BUCK1_RSPPUP[2] = 1																																																																	
RSP	FBDIV	V_{OUT} Ramp Speed mV/μs																																																															
		Fast	Slow																																																														
0x0	1.0	6	1.2																																																														
0x1	1.0	12	3																																																														
0x2	1.0	28.8	7.2																																																														
0x3	1.0	57.6	14.4																																																														
RSP	FBDIV	V_{OUT} Ramp Speed mV/μs																																																															
		Fast	Slow																																																														
0x0 0x2	0.8/0.6	12	3																																																														
0x1 0x3	0.8/0.6	24	6																																																														
3	BUCK1_RSPCFG0RSVD0	R	0x0	Reserved																																																													
2:0	BUCK1_RSPPDN[2:0]	R/W	0x3	This slew rate is used when the current voltage is greater than 0V and the target voltage is 0V. See BUCK1_RSPUP bit descriptions for decode information.																																																													
BUCK1_EN_DLY																																																																	
0x80	7:6	Reserved	R	0x0	Reserved																																																												
	5:0	BUCK1_EN_DLY	R/W	0x00	Delay time from BUCK1_EN and IO_REGVAID going high to Buck1 V _{OUT} actually ramping up. Delay = (integer value of register) ms [1ms/LSB] <table border="1"> <tr> <td></td> <td>Delay</td> </tr> <tr> <td>0x00</td> <td>0</td> </tr> <tr> <td>0x01</td> <td>1ms</td> </tr> <tr> <td>0x02</td> <td>2ms</td> </tr> <tr> <td>...</td> <td></td> </tr> <tr> <td>0x3F</td> <td>63ms</td> </tr> </table>		Delay	0x00	0	0x01	1ms	0x02	2ms	...		0x3F	63ms																																																
	Delay																																																																
0x00	0																																																																
0x01	1ms																																																																
0x02	2ms																																																																
...																																																																	
0x3F	63ms																																																																
BUCK1_SHUTDN_DLY																																																																	
0x81	7:6	Reserved	R	0x0	Reserved																																																												
	5:0	BUCK1_SHUTDN_DLY	R/W	0x00	Delay time from BUCK1_EN and IO_REGVAID going low to Buck1 V _{OUT} actually ramping down. Delay = (integer value of register) ms [1ms/LSB] See " BUCK1_EN_DLY " for description																																																												

Address	Bit	Name	R/W	Default	Description
BUCK2_EA2					
0x82	7:6	BUCK2_VOUTFBDIV	R/W	0x0	Buck2 FBDIV configuration. See "BUCK1_EA2" on page 69 for description
	5:0	Reserved	R	0x1B	Reserved
BUCK2_DCM					
0x85	7:3	Reserved	R	0x0	Reserved
	2	BUCK2_FCCM	R/W	0x0	Buck2 DCM configuration. See "BUCK1_DCM" on page 69 for description
	1:0	Reserved	R	0x0	Reserved
BUCK2_CFG3					
0x86	7:6	BUCK2_FSEL	R	0x2	Buck's steady state frequency. See "BUCK1_CFG3" on page 69 for description
	5:4	Reserved	R/W	0x2	Reserved
	3:0	Reserved	R	0x0 0x1	Reserved Note: Default = 0x0 for 3+1, 0x1 for 2+2 configuration, N/A for 4+0
BUCK2_PROTCFG					
0x8A	7:4	Reserved	R	0x0	See "BUCK1_PROTCFG" on page 70
	3	BUCK2_ENUVOV	R/W	0x1	
	2	BUCK2_OVNOHYS	R/W	0x1	
	1:0	BUCK2_UVOVTH	R/W	0x2	
BUCK2_DVS0CFG1					
0x8E	7:0	BUCK2_DVS0VOUT92	R/W	0xFF	See "BUCK1_DVS0CFG1" on page 70
BUCK2_DVS0CFG0					
0x8F	7:6	BUCK2_DVS0VOUT10	R/W	0x3	See "BUCK1_DVS0CFG0" on page 71
	5	BUCK2_DVS0DECAY	R/W	0x0	
	4:0	Reserved	R	0x0	
BUCK2_DVS1CFG1					
0x90	7:0	BUCK2_DVS1VOUT92	R/W	0xBF	See "BUCK1_DVS0CFG1" on page 70
BUCK2_DVS1CFG0					
0x91	7:6	BUCK2_DVS1VOUT10	R/W	0x3	See "BUCK1_DVS0CFG0" on page 71
	5	BUCK2_DVS1DECAY	R/W	0x0	
	4:0	Reserved	R	0x0	
BUCK2_DVS2CFG1					
0x92	7:0	BUCK2_DVS2VOUT92[7:0]	R/W	0x58	See "BUCK1_DVS0CFG1" on page 70
BUCK2_DVS2CFG0					
0x93	7:6	BUCK2_DVS2VOUT10	R/W	0x0	See "BUCK1_DVS0CFG0" on page 71
	5	BUCK2_DVS2DECAY	R/W	0x0	
	4:0	Reserved	R	0x0	
BUCK2_DVS3CFG1					
0x94	7:0	BUCK2_DVS3VOUT92	R/W	0x00	See "BUCK1_DVS0CFG1" on page 70
BUCK2_DVS3CFG0					
0x95	7:6	BUCK2_DVS3VOUT10	R/W	0x0	See "BUCK1_DVS0CFG0" on page 71
	5	BUCK2_DVS3DECAY	R/W	0x0	
	4:0	Reserved	R	0x0	

Address	Bit	Name	R/W	Default	Description
BUCK2_VOUTMAXMSB					
0x96	7:2	Reserved	R	0x00	Reserved
	1:0	BUCK2_VOUTMAX98[1:0]	R/W	0x3	
BUCK2_VOUTMAXLSB					
0x97	7:0	BUCK2_VOUTMAXLSB[7:0]	R/W	0xFF	Lower byte of V _{OUT} Maximum Programming Limit Data format is same as BUCK2_DVS[3:0]VOUT[9:0]
BUCK2_DVSCFG					
0x98	7:5	Reserved	R	0x0	See "BUCK1_DVSCFG" on page 72
	4	BUCK2_PGOODDAC0V	R/W	0x0	
	3:2	BUCK2_PGOODDELAY	R/W	0x0	
	1:0	BUCK2_DVSPIN_CTRL	R/W	0x0	
BUCK2_DVSSEL					
0x99	7:3	Reserved	R	0x00	See "BUCK1_DVSSEL" on page 73
	2	BUCK2_DVSCTRL	R/W	0x0	
	1:0	BUCK2_DVSSELECT	R/W	0x0	
BUCK2_RSPCFG1					
0x9A	7	Reserved	R	0x0	See "BUCK1_RSPCFG1" on page 74
	6:4	BUCK2_RSPUP	R/W	0x7	
	3	Reserved	R	0x0	
	2:0	BUCK2_RSPDN[2:0]	R/W	0x3	
BUCK2_RSPCFG0					
0x9B	7	Reserved	R	0x0	See "BUCK1_RSPCFG0" on page 75
	6:4	BUCK2_RSPPUP[2:0]	R/W	0x7	
	3	Reserved	R	0x0	
	2:0	BUCK2_RSPPDN[2:0]	R/W	0x3	
BUCK2_EN_DLY					
0x9C	7:6	Reserved	R	0x0	See "BUCK1_EN_DLY" on page 75
	5:0	BUCK2_EN_DLY	R/W	0x00	
BUCK2_SHUTDN_DLY					
0x9D	7:6	Reserved	R	0x0	See "BUCK1_SHUTDN_DLY" on page 75
	5:0	BUCK2_SHUTDN_DLY	R/W	0x00	

11. Revision History

Rev.	Date	Description
3.01	Feb 2, 2022	<p>Removed Related Literature section.</p> <p>Updated Ordering Information table formatting.</p> <p>Updated Table 2 to show pinmode 0x2 and 0xF options, and mark as reserved.</p> <p>Clarify and correct temperature ratings and conditions in the Thermal Information, Recommended Operation Conditions, and Analog Specifications sections.</p> <p>Fixed incorrect IC part number in the Dynamic Voltage Scaling (DVS) and Power Sequencing sections.</p> <p>Added Eq.1 for 10-bit DAC to V_{OUT} transfer function and removed Table 12.</p> <p>Updated and added numerous registers and details to Register Address Map and Register Description by Address sections.</p> <p>Added FBDIV settings to the description table for 0x66[7:6].</p> <p>Corrected Table of V_{OUT} voltages in register 0x72.</p> <p>Updated ADC Telemetry section.</p>
3.00	Feb 20, 2020	<p>Updated Typical App Circuits.</p> <p>Added Note 1 to Ordering Information table.</p> <p>Updated Figure titles for Figures 16-11.</p> <p>Updated Figures 19, 20, 36, 38.</p> <p>Updated Table 12.</p> <p>Added the following sentence to section 7.1 on page 30: "The ISL91302B does not support SPI reads on the MISO bus when using multiple slave devices on the same bus."</p> <p>Removed registers 0x78 (BUCK1_DVS3CFG1), and 0x82 (BUCK2EA2) and added registers 0x78 (BUCK2_DCM) and 0x86 (BUCK_CFG3) to Register Address Map on page 40.</p> <p>Added descriptions for registers BUCK1_DCM, BUCK1_CFG3, BUCK2_DCM, BUCK2_CFG3, ADC_BUCK1CFG, and ADC_BUCK2CFG to section 10, Register Descriptions.</p> <p>Updated disclaimer.</p>
2.00	Apr 5, 2018	<p>Updated Figures 3-5: INT (output) WDOG_RST (Input)</p> <p>Updated Note 2.</p> <p>Updated Parameter from "PVIN to GND" to "PVIN to PGND" on page 10.</p> <p>Updated the test condition for CCM Frequency Tolerance from 3MHz to 4MHz on page 12.</p> <p>Updated Figures 24 and 26.</p>
1.00	Feb 28, 2018	<p>Updated Title</p> <p>Updated Figure 1</p> <p>Added Table 1 on page 6.</p> <p>Updated the Analog Specifications Conditions in table heading.</p> <p>Added Buck Output Voltage Range, and Output Voltage Step Size for BUCKx_VOUTFBDIV[1:0] = 0x00, BUCKx_VOUTFBDIV[1:0] = 0x01, BUCKx_VOUTFBDIV[1:0] = 0x02 in Spec table on page 11.</p> <p>Added High-Side and Low-Side Switch On-Resistance specs on page 12.</p> <p>Updated Table 5.</p> <p>Updated Figure 30.</p> <p>Updated Data Hold Time minimum specifications for all modes in Table 18 on page 35 (changed from 0ns to 15ns).</p> <p>Updated IO_CHIPNAME description on page 41.</p> <p>Updated FLT_RECORDBUCK2 Bits 1, 3, 5 names on page 44.</p> <p>Added Default information for FLT_OT_CTRL on page 61 and BUCK1_RSPCFG1 on page 67.</p> <p>Updated description for BUCK1_DVS0CFG1 on page 64 (changed 0.4V to 0.3V).</p> <p>Removed About Intersil section.</p> <p>Updated disclaimer.</p>
0.00	Sep 22, 2017	Initial release

12. Package Outline Drawing

For the most recent package outline drawing, see [W6x9.54](#).

W6x9.54

54 Ball Wafer Level Chip Scale Package (WLCSP 0.4mm PITCH)

Rev 0, 10/15

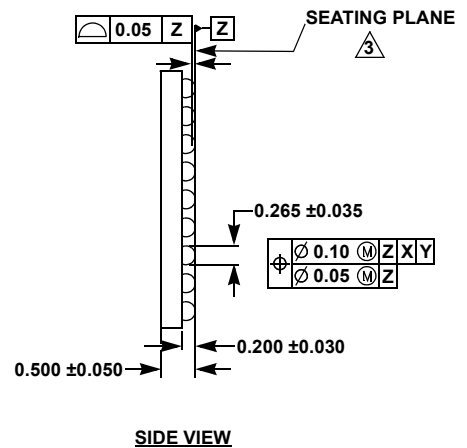
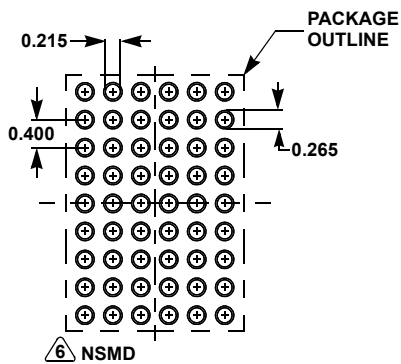
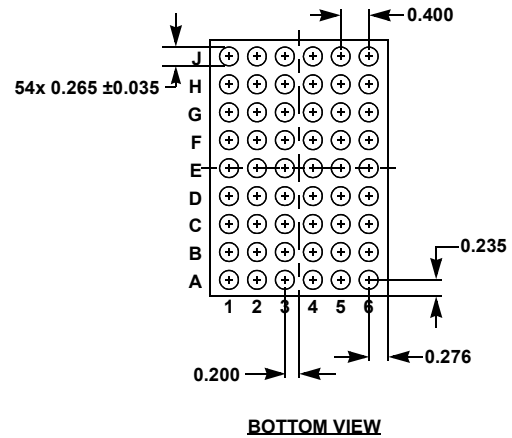
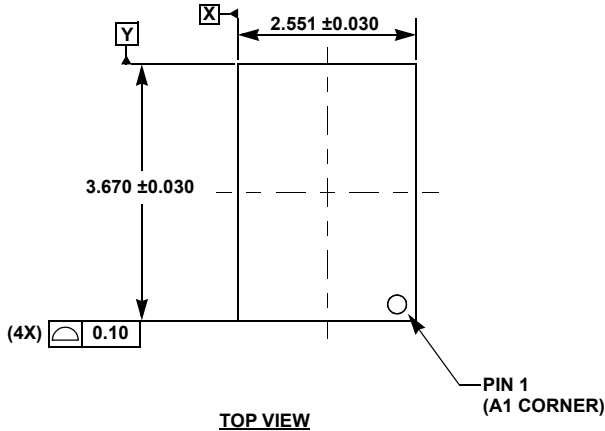

NOTES:

1. All dimensions are in millimeters.
2. Dimensions and tolerance per ASME Y 14.5M - 1994.
3. Primary datum Z and seating plane are defined by the spherical crowns of the bump.
4. Dimension is measured at the maximum bump diameter parallel to primary datum Z .
5. Bump position designation per JESD 95-1, SPP-010.
6. NSMD refers to non-solder mask defined pad design per [TB451](#).

IMPORTANT NOTICE AND DISCLAIMER

RENESAS ELECTRONICS CORPORATION AND ITS SUBSIDIARIES (“RENESAS”) PROVIDES TECHNICAL SPECIFICATIONS AND RELIABILITY DATA (INCLUDING DATASHEETS), DESIGN RESOURCES (INCLUDING REFERENCE DESIGNS), APPLICATION OR OTHER DESIGN ADVICE, WEB TOOLS, SAFETY INFORMATION, AND OTHER RESOURCES “AS IS” AND WITH ALL FAULTS, AND DISCLAIMS ALL WARRANTIES, EXPRESS OR IMPLIED, INCLUDING, WITHOUT LIMITATION, ANY IMPLIED WARRANTIES OF MERCHANTABILITY, FITNESS FOR A PARTICULAR PURPOSE, OR NON-INFRINGEMENT OF THIRD PARTY INTELLECTUAL PROPERTY RIGHTS.

These resources are intended for developers skilled in the art designing with Renesas products. You are solely responsible for (1) selecting the appropriate products for your application, (2) designing, validating, and testing your application, and (3) ensuring your application meets applicable standards, and any other safety, security, or other requirements. These resources are subject to change without notice. Renesas grants you permission to use these resources only for development of an application that uses Renesas products. Other reproduction or use of these resources is strictly prohibited. No license is granted to any other Renesas intellectual property or to any third party intellectual property. Renesas disclaims responsibility for, and you will fully indemnify Renesas and its representatives against, any claims, damages, costs, losses, or liabilities arising out of your use of these resources. Renesas' products are provided only subject to Renesas' Terms and Conditions of Sale or other applicable terms agreed to in writing. No use of any Renesas resources expands or otherwise alters any applicable warranties or warranty disclaimers for these products.

(Rev.1.0 Mar 2020)

Corporate Headquarters

TOYOSU FORESIA, 3-2-24 Toyosu,
Koto-ku, Tokyo 135-0061, Japan
www.renesas.com

Contact Information

For further information on a product, technology, the most up-to-date version of a document, or your nearest sales office, please visit:
www.renesas.com/contact/

Trademarks

Renesas and the Renesas logo are trademarks of Renesas Electronics Corporation. All trademarks and registered trademarks are the property of their respective owners.

Mouser Electronics

Authorized Distributor

Click to View Pricing, Inventory, Delivery & Lifecycle Information:

[Renesas Electronics:](#)

[ISL91302BIIZ-T](#) [ISL91302B31-EVZ](#) [ISL91302B40-EVZ](#)