

## Low-power quad voltage comparator

Datasheet - production data

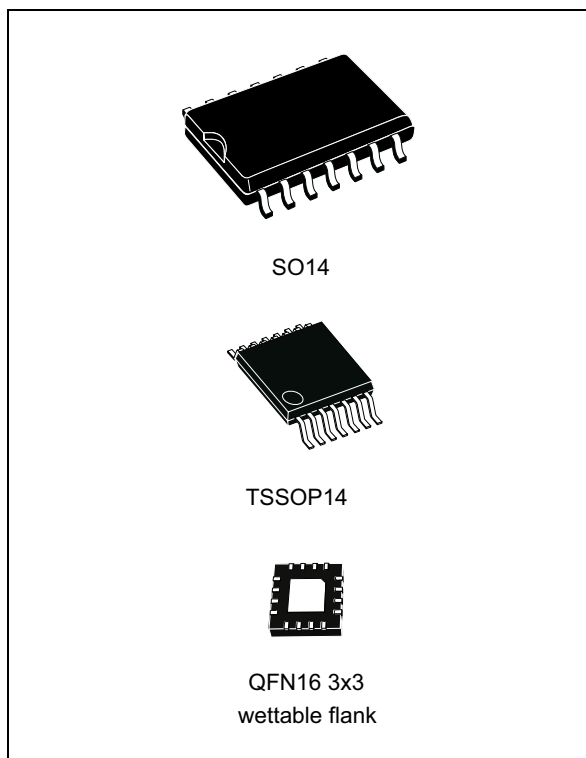

- Input common-mode voltage range includes negative rail
- Low output saturation voltage: 250 mV typ. ( $I_O = 4$  mA)
- Differential input voltage range equal to the supply voltage
- TTL, DTL, ECL, MOS, CMOS compatible outputs

### Description

This device consists of four independent precision voltage comparators, which are designed specifically to operate from a single supply over a wide range of voltages. Operation from split power supplies is also possible.

These comparators also have a unique characteristic in that the input common-mode voltage range includes the negative rail even though operated from a single power supply voltage.

### Features

- Wide single supply voltage range or dual supplies for all devices: +2 V to +36 V or  $\pm 1$  V to  $\pm 18$  V
- Very low supply current (1.1 mA) independent of supply voltage (1.4 mW/comparator at +5 V)
- Low input bias current: 25 nA typ.
- Low input offset current:  $\pm 5$  nA typ.

# Contents

- 1 Pin connection and schematic diagram ..... 3**
- 2 Absolute maximum ratings and operating conditions ..... 4**
- 3 Electrical characteristics ..... 5**
- 4 Typical application schematics ..... 7**
- 5 Package information ..... 10**
  - 5.1 QFN16 3 x 3 package information .....11
  - 5.2 QFN16 3 x 3 wettable flank package information ..... 14
  - 5.3 SO-14 package information ..... 16
  - 5.4 TSSOP14 package information ..... 17
- 6 Ordering information ..... 18**
- 7 Revision history ..... 19**

# 1 Pin connection and schematic diagram

Figure 1. Pin connections (top view)

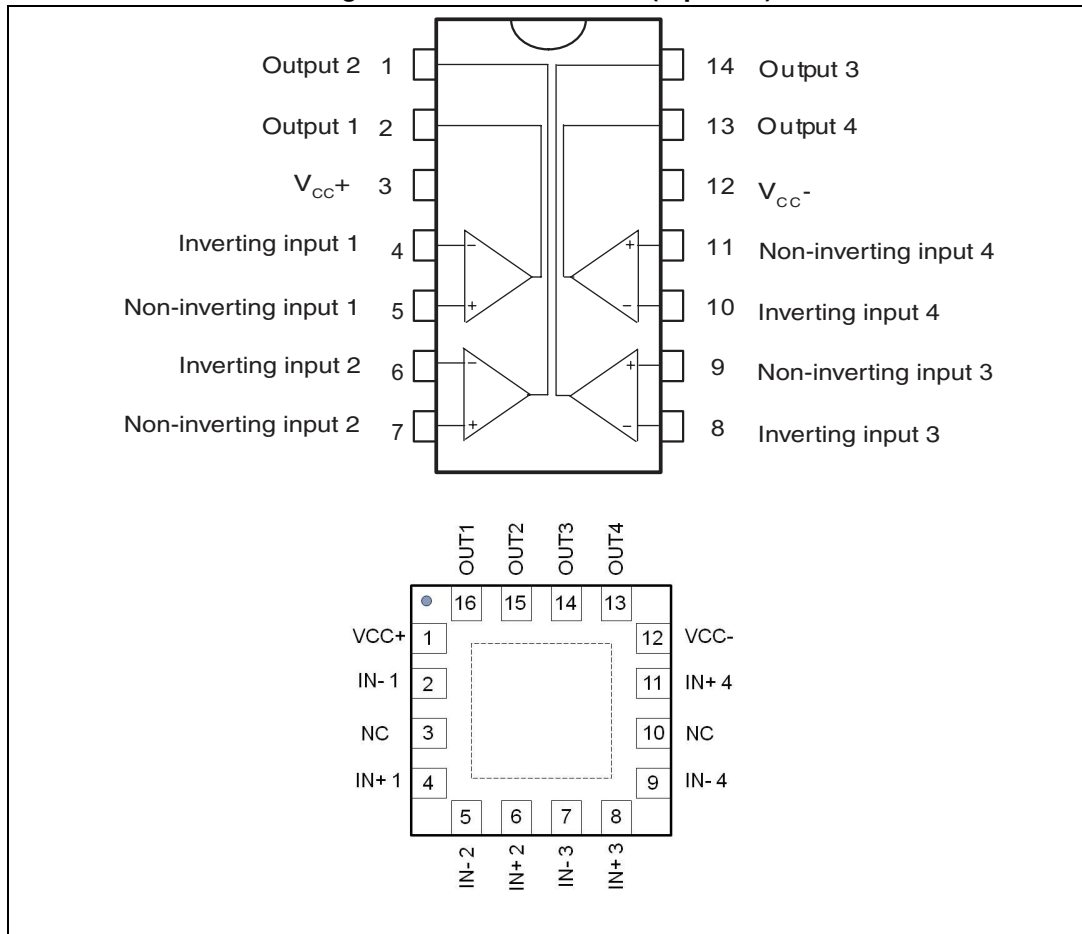
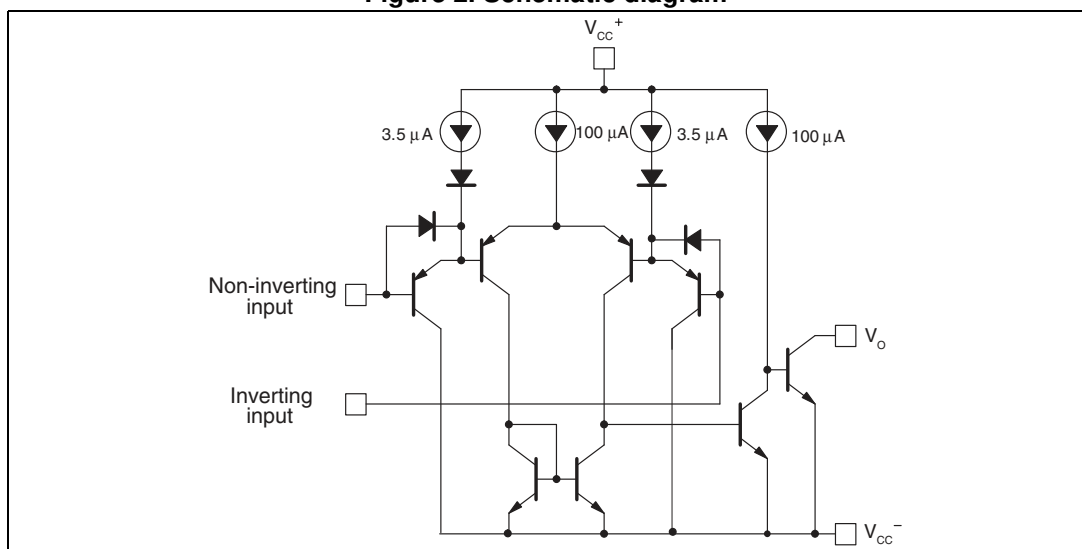

Figure 2. Schematic diagram



## 2 Absolute maximum ratings and operating conditions

**Table 1. Absolute maximum ratings**

Symbol	Parameter	Value	Unit
$V_{CC}$	Supply voltage	$\pm 18$ to 36	V
$V_{id}$	Differential input voltage	$\pm 36$	V
$V_{in}$	Input voltage	-0.3 to +36	V
	Output short-circuit to ground <sup>(1)</sup>		
$R_{thja}$	Thermal resistance junction to ambient <sup>(2)</sup>		°C/W
	DIP14	80	
	SO-14	105	
	TSSOP14 QFN16 3x3	100 45	
$R_{thjc}$	Thermal resistance junction to case <sup>(2)</sup>		
	DIP14	33	
	SO-14	31	
	TSSOP14 QFN16 3x3	32 14	
$T_j$	Maximum junction temperature	+150	°C
$T_{stg}$	Storage temperature range	-65 to +150	°C
ESD	HBM: human body model <sup>(3)</sup>	500	V
	MM: machine model <sup>(4)</sup>	100	V
	CDM: charged device model <sup>(5)</sup>	1500	V

- Short-circuits from the output to  $V_{CC}^+$  can cause excessive heating and eventual destruction. The maximum output current is approximately 20 mA, independent of the magnitude of  $V_{CC}^+$ .
- Short-circuits can cause excessive heating. Destructive dissipation can result from simultaneous short-circuits on all amplifiers. All values are typical.
- Human body model: a 100 pF capacitor is charged to the specified voltage, then discharged through a 1.5 kΩ resistor between two pins of the device. This is done for all couples of connected pin combinations while the other pins are floating.
- Machine model: a 200 pF capacitor is charged to the specified voltage, then discharged directly between two pins of the device with no external series resistor (internal resistor < 5 Ω). This is done for all couples of connected pin combinations while the other pins are floating.
- Charged device model: all pins and the package are charged together to the specified voltage and then discharged directly to the ground through only one pin. This is done for all pins.

**Table 2. Operating conditions**

Symbol	Parameter	Value	Unit
$V_{CC}$	Supply voltage	2 to 32 $\pm 1$ to $\pm 16$	V
$V_{icm}$	Common mode input voltage range $T_{min} \leq T_{amb} \leq T_{max}$	0 to ( $V_{CC}^+ - 1.5$ ) 0 to ( $V_{CC}^+ - 2$ )	V
$T_{oper}$	Operating free-air temperature range	-40 to +125	°C

### 3 Electrical characteristics

**Table 3. Electrical characteristics at  $V_{CC}^+ = 5\text{ V}$ ,  $V_{CC}^- = \text{GND}$ ,  $T_{\text{amb}} = 25^\circ\text{ C}$   
(unless otherwise specified)**

Symbol	Parameter	Min.	Typ.	Max.	Unit
$V_{\text{io}}$	Input offset voltage <sup>(1)</sup> $T_{\text{min}} \leq T_{\text{amb}} \leq T_{\text{max}}$		1	7 15	mV
$I_{\text{io}}$	Input offset current $T_{\text{min}} \leq T_{\text{amb}} \leq T_{\text{max}}$		5	50 150	nA
$I_{\text{ib}}$	Input bias current ( $I_{\text{I}^+}$ or $I_{\text{I}^-}$ ) <sup>(2)</sup> $T_{\text{min}} \leq T_{\text{amb}} \leq T_{\text{max}}$		25	250 400	nA
$A_{\text{vd}}$	Large signal voltage gain ( $V_{\text{CC}} = 15\text{ V}$ , $R_{\text{L}} = 15\text{ k}\Omega$ , $V_{\text{o}} = 1$ to $11\text{ V}$ )	25	200		V/mV
$I_{\text{CC}}$	Supply current (all comparators) $V_{\text{CC}} = +5\text{ V}$ , no load $V_{\text{CC}} = +30\text{ V}$ , no load		1.1 1.3	2 2.5	mA
$V_{\text{id}}$	Differential input voltage <sup>(3)</sup>			$V_{\text{CC}}^+$	V
$V_{\text{OL}}$	Low level output voltage $V_{\text{id}} = -1\text{ V}$ , $I_{\text{sink}} = 4\text{ mA}$ $T_{\text{min}} \leq T_{\text{amb}} \leq T_{\text{max}}$		250	400 700	mV
$I_{\text{OH}}$	High level output current ( $V_{\text{CC}} = V_{\text{o}} = 30\text{ V}$ , $V_{\text{id}} = 1\text{ V}$ $T_{\text{min}} \leq T_{\text{amb}} \leq T_{\text{max}}$ )		0.1	1	nA $\mu\text{A}$
$I_{\text{sink}}$	Output sink current ( $V_{\text{id}} = -1\text{ V}$ , $V_{\text{o}} = 1.5\text{ V}$ )	6	16		mA
$t_{\text{res}}$	Small signal response time <sup>(4)</sup> ( $R_{\text{L}} = 5.1\text{ k}\Omega$ connected to $V_{\text{CC}}^+$ )		1.3		$\mu\text{s}$
$t_{\text{rel}}$	Large signal response time <sup>(5)</sup> TTL input ( $V_{\text{ref}} = +1.4\text{ V}$ , $R_{\text{L}} = 5.1\text{ k}\Omega$ to $V_{\text{CC}}^+$ ) Output signal at 50% of final value Output signal at 95% of final value			500 1	ns $\mu\text{s}$

1. At output switch point,  $V_{\text{o}} \approx 1.4\text{ V}$ ,  $R_{\text{S}} = 0$  with  $V_{\text{CC}}^+$  from  $5\text{ V}$  to  $30\text{ V}$ , and over the full input common-mode range ( $0\text{ V}$  to  $V_{\text{CC}}^+ - 1.5\text{ V}$ ).
2. The direction of the input current is out of the IC due to the PNP input stage. This current is essentially constant, independent of the state of the output, so there is no loading charge on the reference of input lines.
3. The response time specified is for a  $100\text{ mV}$  input step with  $5\text{ mV}$  overdrive.
4. Positive excursions of input voltage may exceed the power supply level. As long as the other voltage remains within the common-mode range, the comparator will provide a proper output state. The low input voltage state must not be less than  $-0.3\text{ V}$  (or  $0.3\text{ V}$  below the negative power supply, if used).
5. Maximum values are guaranteed by design.

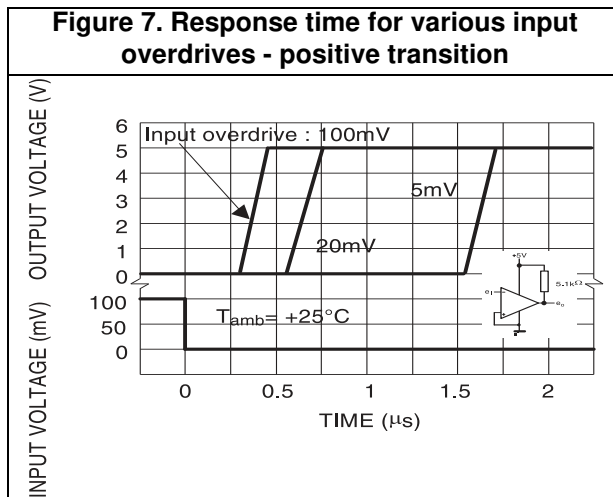
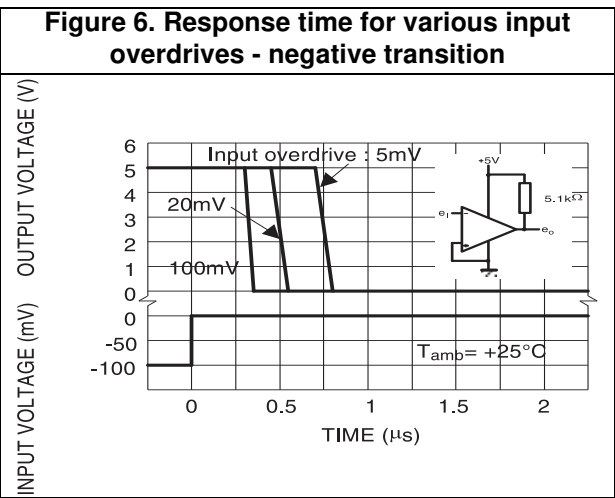
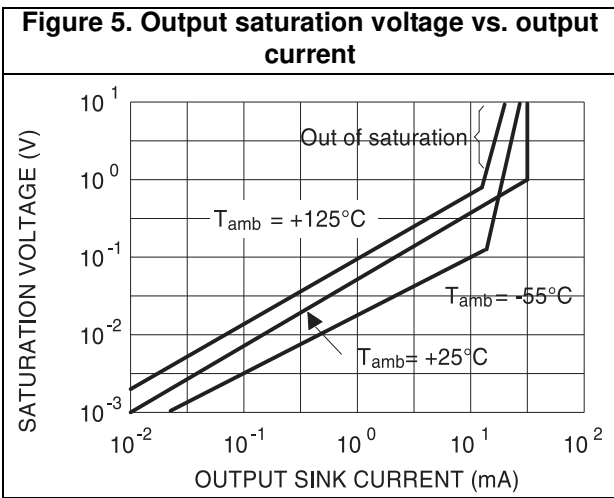
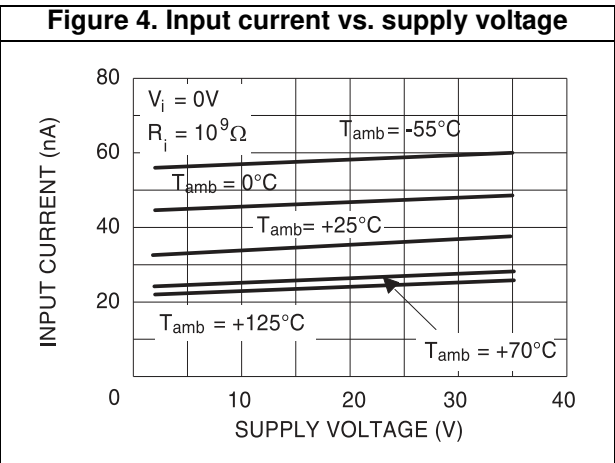
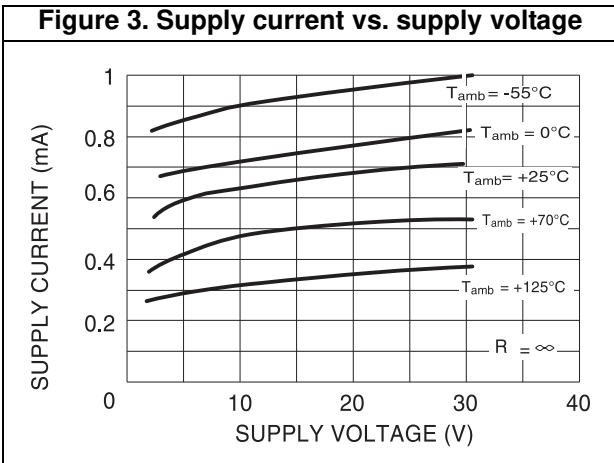

## 4 Typical application schematics

<p><b>Figure 8. Basic comparator</b></p>	<p><b>Figure 9. Driving CMOS</b></p>
<p><b>Figure 10. Driving TTL</b></p>	<p><b>Figure 11. Low frequency op amp</b></p>
<p><b>Figure 12. Low frequency op amp with boost</b></p> <p>(<math>e_o = 0</math> V for <math>e_i = 0</math> V)</p>	<p><b>Figure 13. Transducer amplifier</b></p>

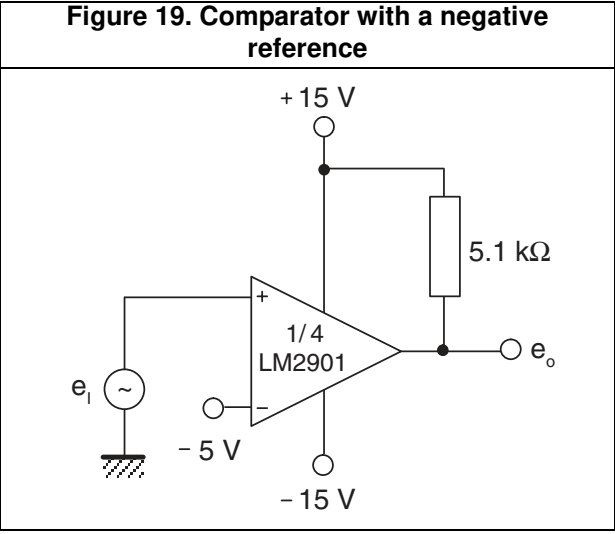
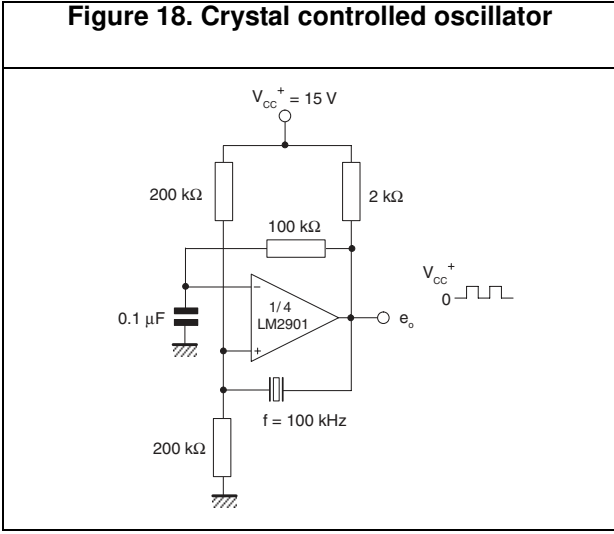
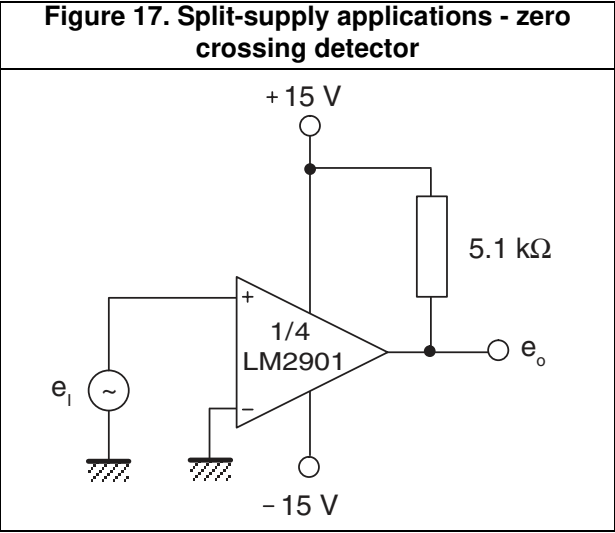
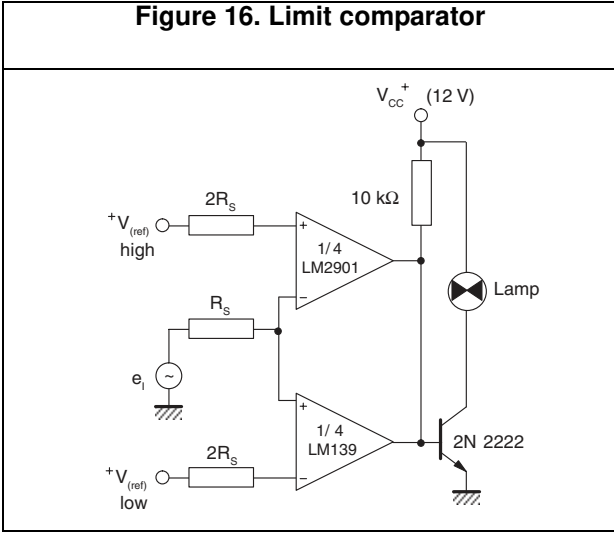
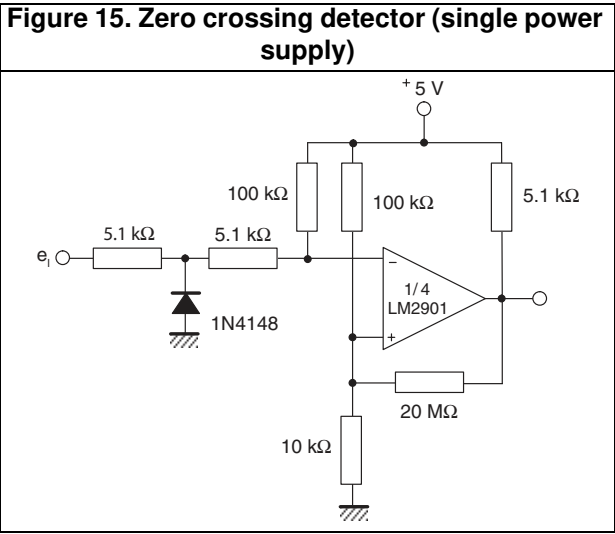
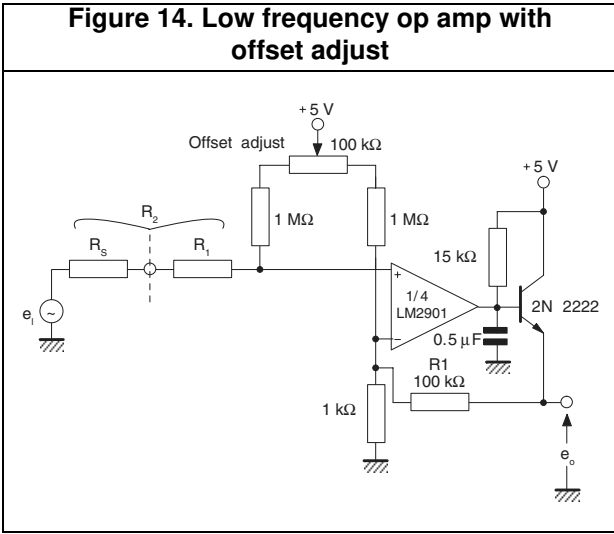





## 5 Package information

In order to meet environmental requirements, ST offers these devices in different grades of ECOPACK packages, depending on their level of environmental compliance. ECOPACK specifications, grade definitions and product status are available at: [www.st.com](http://www.st.com). ECOPACK is an ST trademark.

### 5.1 QFN16 3 x 3 package information

Figure 22. QFN16 3 x 3 mm package mechanical drawing

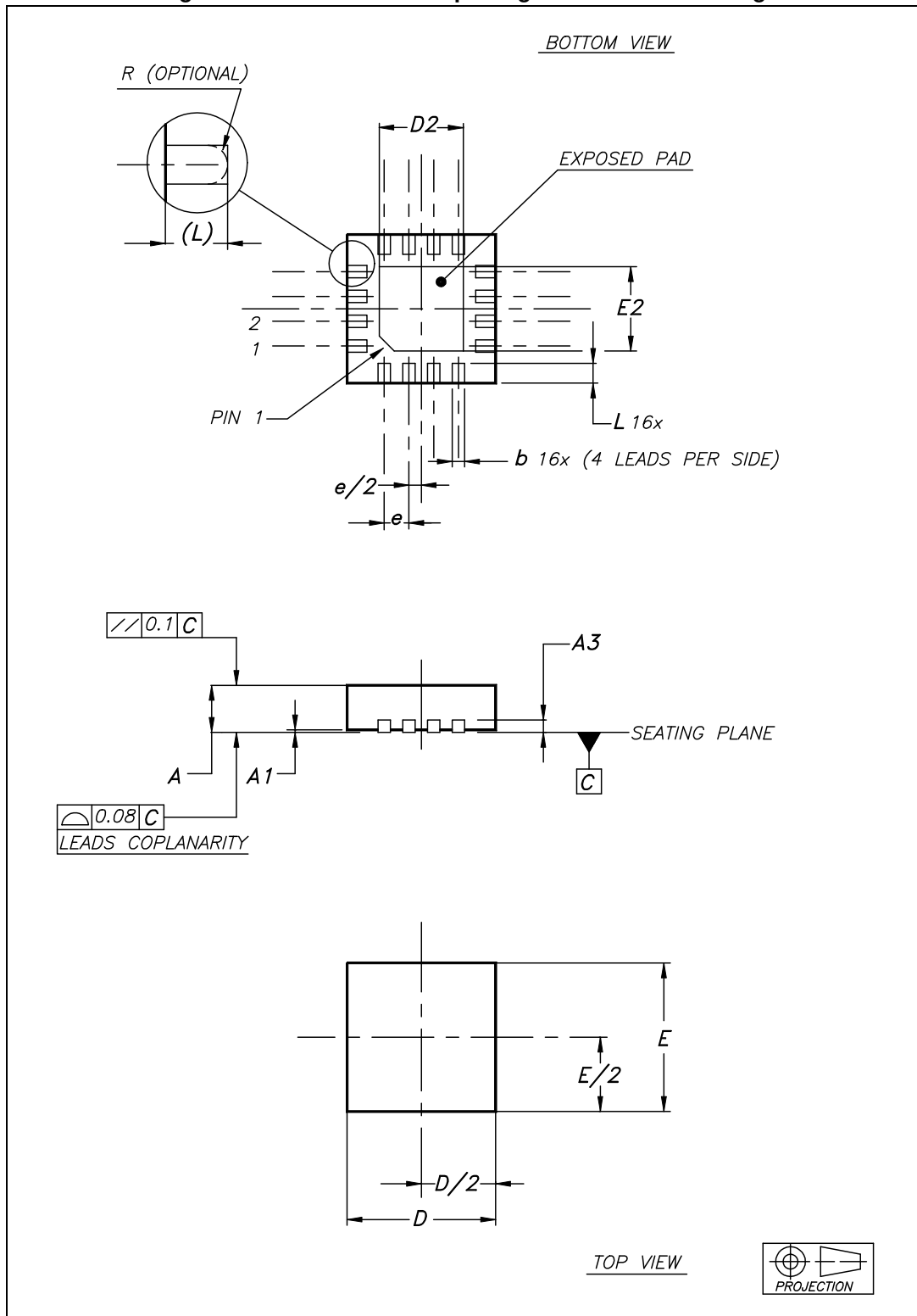
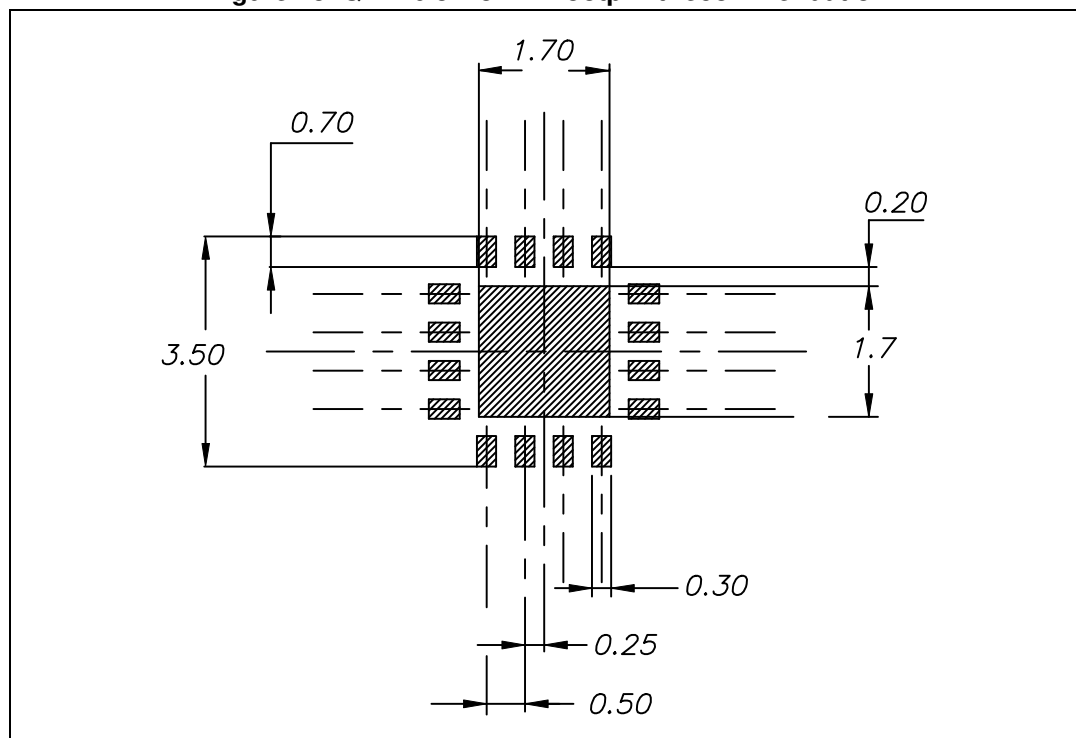

Table 4. QFN16 3 x 3 mm package mechanical data (pitch 0.5 mm)

Ref.	Dimensions					
	Millimeters			Inches		
	Min.	Typ.	Max.	Min.	Typ.	Max.
A	0.80	0.90	1.00	0.031	0.035	0.039
A1	0		0.05	0		0.002
A3		0.20			0.008	
b	0.18		0.30	0.007		0.012
D	2.90	3.00	3.10	0.114	0.118	0.122
D2	1.50		1.80	0.059		0.071
E	2.90	3.00	3.10	0.114	0.118	0.122
E2	1.50		1.80	0.059		0.071
e		0.50			0.020	
L	0.30		0.50	0.012		0.020

Figure 23. QFN16 3 x 3 mm footprint recommendation



## 5.2 QFN16 3 x 3 wettable flank package information

Figure 24. QFN16 3 x 3 mm wettable flank drawing outline

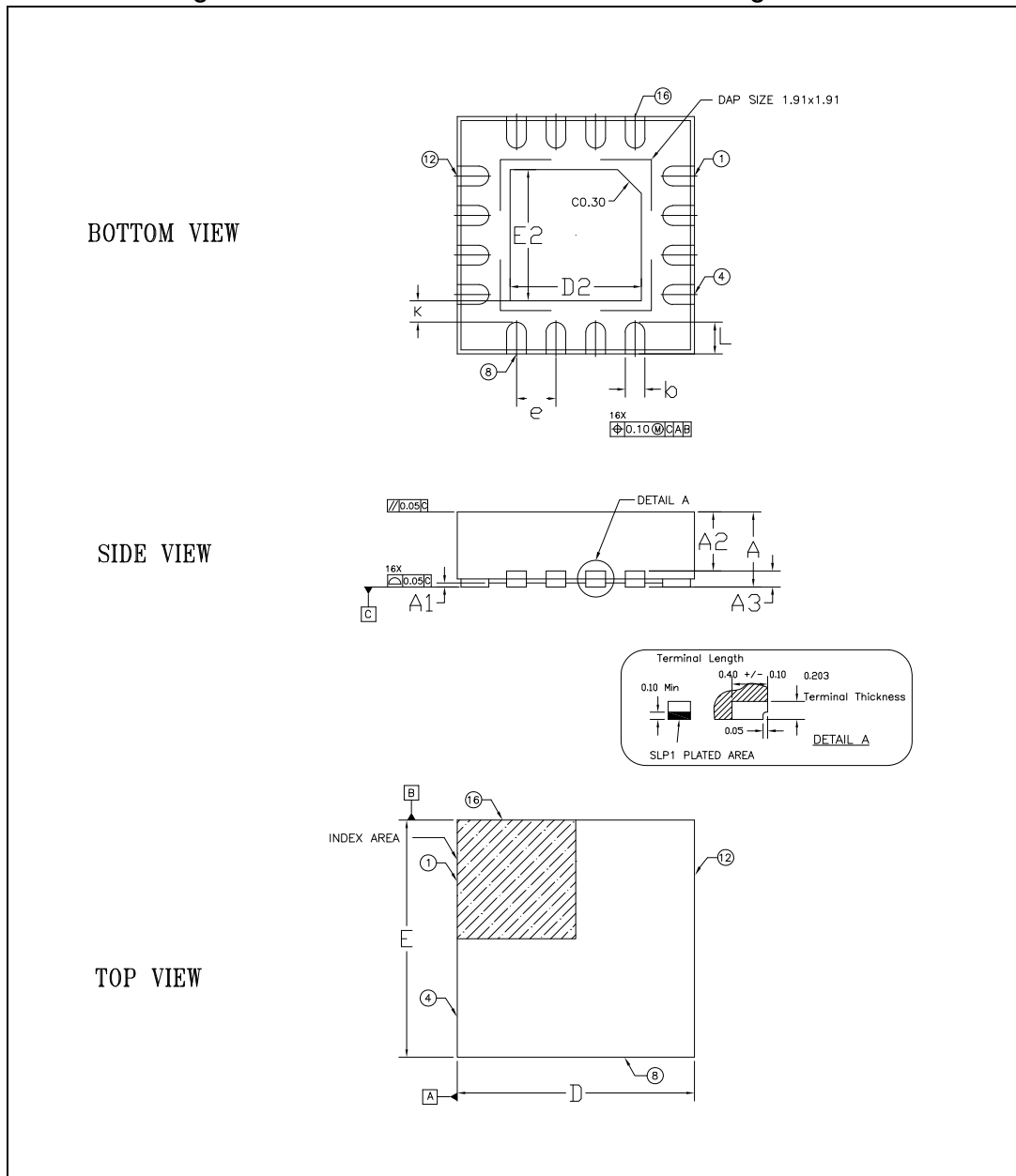
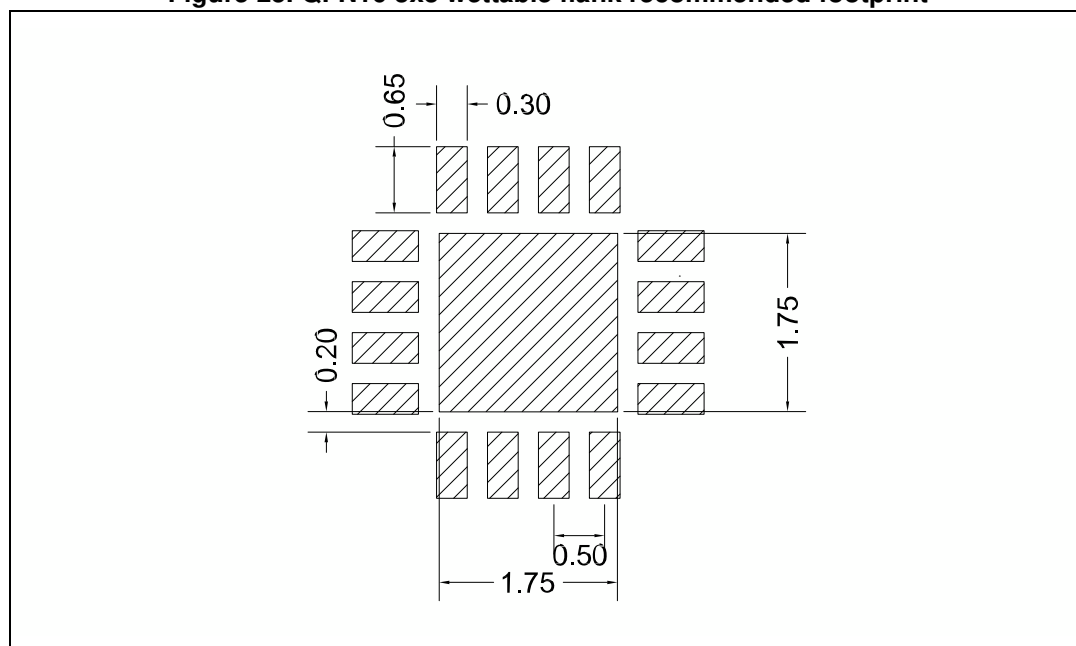

Table 5. QFN16 3x3 wettable flank mechanical data

Ref.	Dimensions					
	Millimeters			Inches		
	Min.	Typ.	Max.	Min.	Typ.	Max.
A	0.90	0.95	1.00	0.035	0.037	0.039
A1	0		0.05	0		0.002
A2		0.75			0.030	
A3		0.20			0.008	
b	0.20	0.25	0.30	0.008	0.010	0.012
D		3.00			0.118	
E		3.00			0.118	
e		0.50			0.020	
D2	1.56	1.66	1.76	0.061	0.065	0.069
E2	1.56	1.66	1.76	0.061	0.065	0.069
K		0.27			0.011	
L	0.30	0.40	0.50	0.012	0.016	0.020

Figure 25. QFN16 3x3 wettable flank recommended footprint



### 5.3 SO-14 package information

Figure 26. SO-14 package mechanical drawing

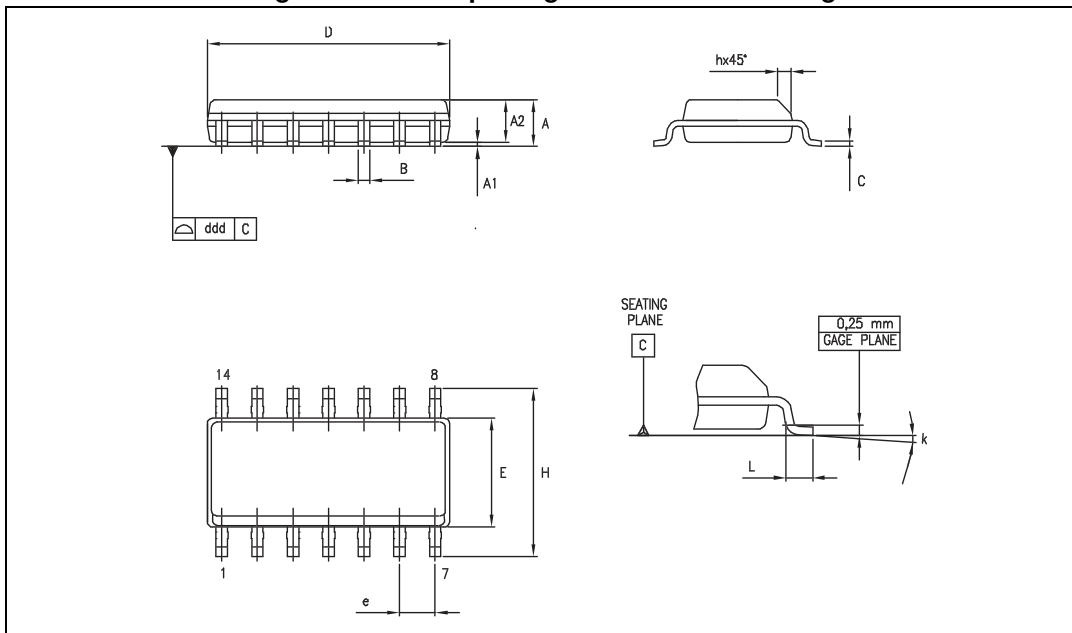

Table 6. SO-14 package mechanical data

Dimensions						
Ref.	Millimeters			Inches		
	Min.	Typ.	Max.	Min.	Typ.	Max.
A	1.35		1.75	0.05		0.068
A1	0.10		0.25	0.004		0.009
A2	1.10		1.65	0.04		0.06
B	0.33		0.51	0.01		0.02
C	0.19		0.25	0.007		0.009
D	8.55		8.75	0.33		0.34
E	3.80		4.0	0.15		0.15
e		1.27			0.05	
H	5.80		6.20	0.22		0.24
h	0.25		0.50	0.009		0.02
L	0.40		1.27	0.015		0.05
k	8° (max.)					
ddd			0.10			0.004



### 5.4 TSSOP14 package information

Figure 27. TSSOP14 package mechanical drawing

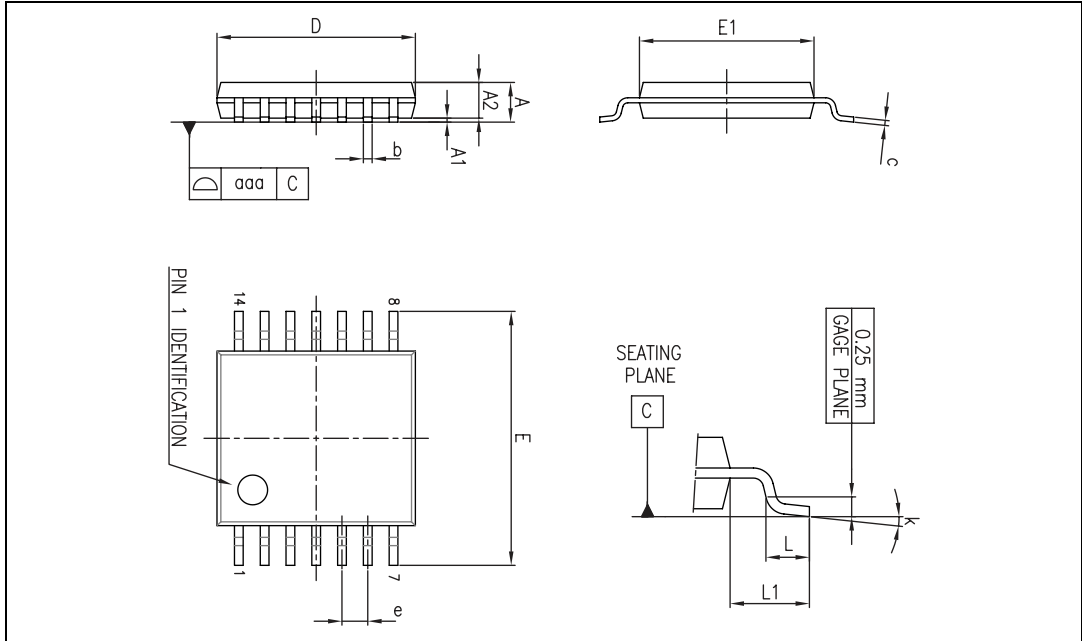

Table 7. TSSOP14 package mechanical data

Ref.	Dimensions					
	Millimeters			Inches		
	Min.	Typ.	Max.	Min.	Typ.	Max.
A			1.20			0.047
A1	0.05		0.15	0.002	0.004	0.006
A2	0.80	1.00	1.05	0.031	0.039	0.041
b	0.19		0.30	0.007		0.012
c	0.09		0.20	0.004		0.0089
D	4.90	5.00	5.10	0.193	0.197	0.201
E	6.20	6.40	6.60	0.244	0.252	0.260
E1	4.30	4.40	4.50	0.169	0.173	0.176
e		0.65			0.0256	
L	0.45	0.60	0.75	0.018	0.024	0.030
L1		1.00			0.039	
k	0°		8°	0°		8°
aaa			0.10			0.004

## 6 Ordering information

**Table 8. Order codes**

Order code	Temperature range	Package	Packing	Marking
LM2901D LM2901DT	-40 °C to +125 °C	SO-14	Tube or tape & reel	2901
LM2901PT		TSSOP14	Tape & reel	K5I
LM2901Q4T		QFN16 3 x 3		K552
LM2901Q5T		QFN16 3 x 3 wetable flank		2901Y
LM2901YDT <sup>(1)</sup>		SO-14 (Automotive grade)		
LM2901YPT <sup>(1)</sup>		TSSOP14 (Automotive grade)		

1. Qualified and characterized according to AEC Q100 and Q003 or equivalent, advanced screening according to AEC Q001 & Q 002 or equivalent.

## 7 Revision history

**Table 9. Document revision history**

Date	Revision	Changes
01-Jan-2002	1	Initial release.
01-Jul-2005	2	1 - PPAP references inserted in the datasheet see Table: Order codes on page 1. 2 - ESD protection inserted in Table 1 on page 3.
01-Oct-2005	3	– The following changes were made in this revision: – – PPAP part number added in table Order codes on page 1. – – Formatting changes throughout.
18-Jul-2006	4	ESD HBM value corrected in Table 1 on page 3.
19-Dec-2007	5	Added $R_{thja}$ and $R_{thjc}$ parameters to Table 1: Absolute maximum ratings. Added footnotes for ESD parameters. Removed $V_{icm}$ parameter from electrical characteristics in Table 3. Reformatted package information in Section 5. Added footnotes for automotive grade parts in Table 8: Order codes.
30-Apr-2009	6	Document reformatted. Updated package information in Chapter 5: Package information. Removed note 2 under Table 8: Order codes.
06-Feb-2012	7	Added QFN16 3 x 3 package in Chapter 5. Removed LM2901YD order code from Table 8.
12-Dec-2022	8	Updated figure on the cover page. Removed DIP14 package. Added new LM2901Q5T order code in Table 8 and new Section 5.2.
23-Jun-2023	9	Updated $I_{sink}$ unit value in <a href="#">Table 3</a> .

**IMPORTANT NOTICE – PLEASE READ CAREFULLY**

STMicroelectronics NV and its subsidiaries (“ST”) reserve the right to make changes, corrections, enhancements, modifications, and improvements to ST products and/or to this document at any time without notice. Purchasers should obtain the latest relevant information on ST products before placing orders. ST products are sold pursuant to ST’s terms and conditions of sale in place at the time of order acknowledgement.

Purchasers are solely responsible for the choice, selection, and use of ST products and ST assumes no liability for application assistance or the design of Purchasers’ products.

No license, express or implied, to any intellectual property right is granted by ST herein.

Resale of ST products with provisions different from the information set forth herein shall void any warranty granted by ST for such product.

ST and the ST logo are trademarks of ST. For additional information about ST trademarks, please refer to [www.st.com/trademarks](http://www.st.com/trademarks). All other product or service names are the property of their respective owners.

Information in this document supersedes and replaces information previously supplied in any prior versions of this document.

© 2023 STMicroelectronics – All rights reserved