

Preliminary Specification of COAXIAL CONNECTOR
 Preliminary SPEC No. : NMM04-PU0025A
 Part Number : MM8930-2620B/RJ4/RK15

Written by : H. Kitaguchi
 Checked by : T. Kuriyama
 Date : 14 /Jun./2013
 Revised A: 18/Jul./'13 MA

SPECIFICATION

1. PART NUMBER

Part Number	Packaging	Quantity	Remarks
MM8930-2620B	Bulk Package	Free	
MM8930-2620RJ4	178 mm dia. reel	4000 pcs/reel	ESD protection
MM8930-2620RK15	330 mm dia. reel	15000 pcs/reel	ESD protection

2. MECHANICAL

A>

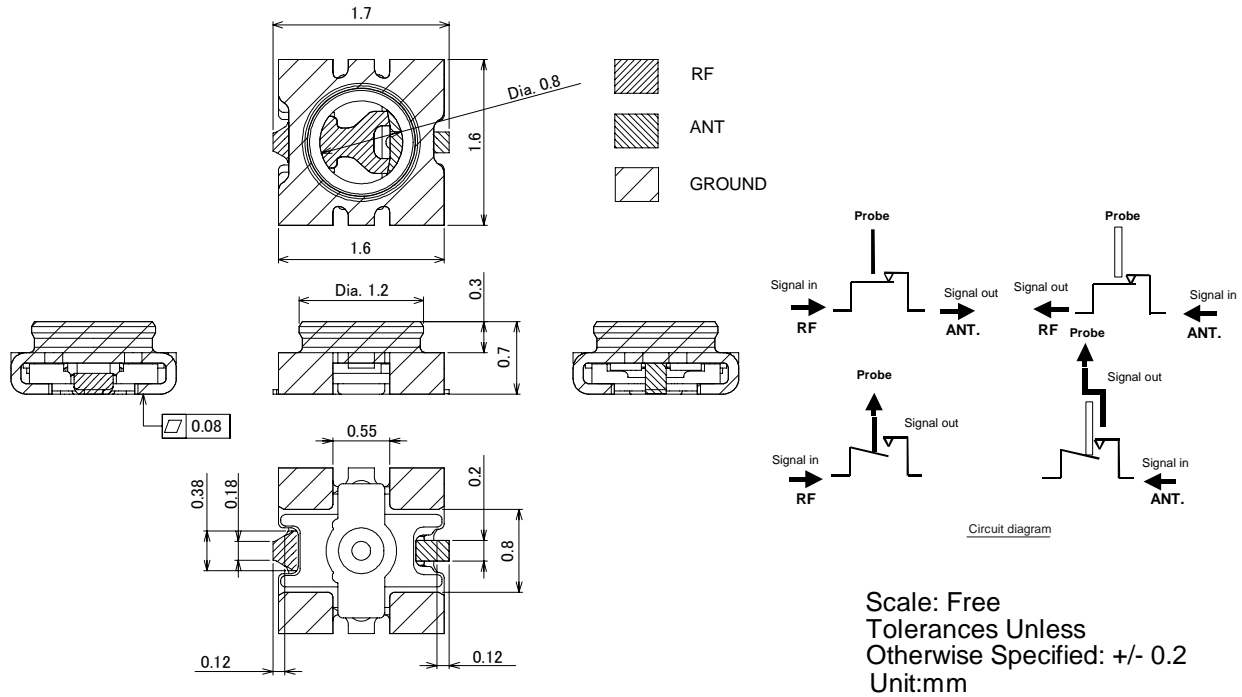

FIGURE1. Construction

3. RATING :

Item	Specification
Voltage Rating	30V r.m.s. maximum
Nominal Frequency Range	DC to 6GHz
Nominal Impedance	50 Ω
Power Rating	2Wmax (at 2GHz)
Temperature Rating	-40°C to +85°C
Insulation Resistance	500 MΩ minimum
Withstanding Voltage	No evidence of break down in AC200Vr.m.s, 1minute
Initial Contact Resistance (without conductor resistance)	70m Ω max.
Voltage Standing Wave Ratio (V.S.W.R.)	1.2 max. (DC to 3GHz) 1.3 max. (3GHz to 6GHz)
Insertion Loss	0.1dB max. (DC to 3GHz) 0.2dB max. (3GHz to 6GHz)
Isolation	Signal in : RF 20dBmin. (DC~3GHz) Signal in : RF 15dBmin. (3GHz ~6GHz) Signal in : ANT 18dBmin. (DC~3GHz) Signal in : ANT 13dBmin. (3GHz ~6GHz)
Durability	50 cycles

4. STANDARD PATTERN DIMENSION

A>

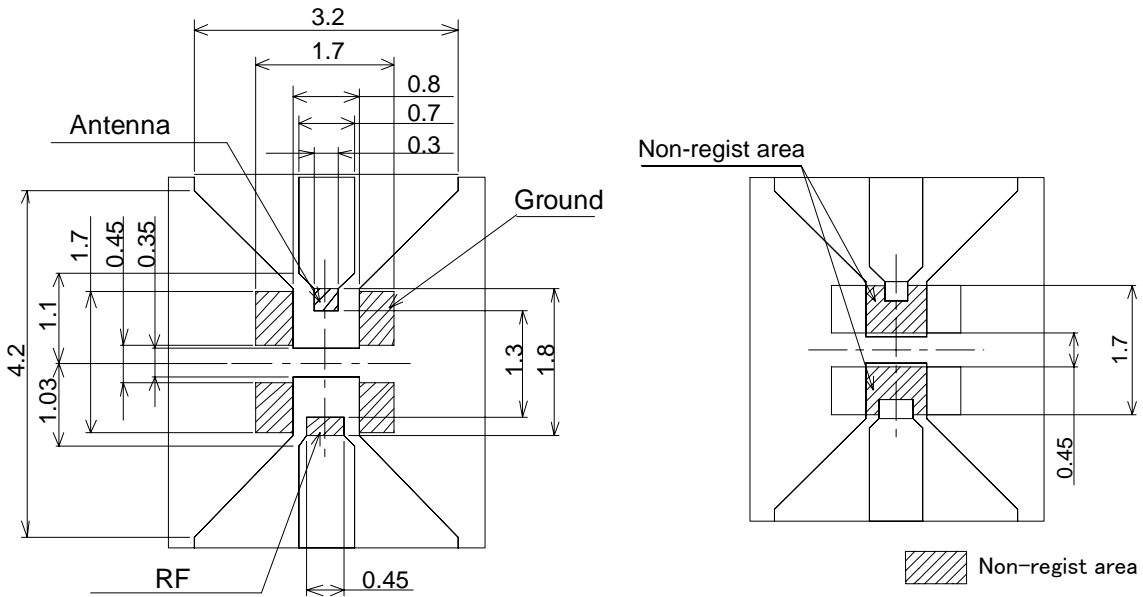

(Note) ·The material of PWB is the epoxy resin of glass fabric base. ($\epsilon_r=4.3$). Thickness is 0.4mm.
 ·The solder resist should be printed except for the land pattern and, Non-regist area on the PWB

FIGURE2. Standard pattern dimensions

There is the possibility to have the contact failure by excess flux in solder, if non-regist area is not secured.

5. STANDARD STENCIL MASK PATTERN

The standard stencil mask pattern is as FIGURE 3.

There is the possibility to have the contact failure by solder shifting into contact point, if the excess solder is used by non standard stencil mask pattern

Thickness $t=0.08\text{mm}$

Thickness $t=0.1\text{mm}$

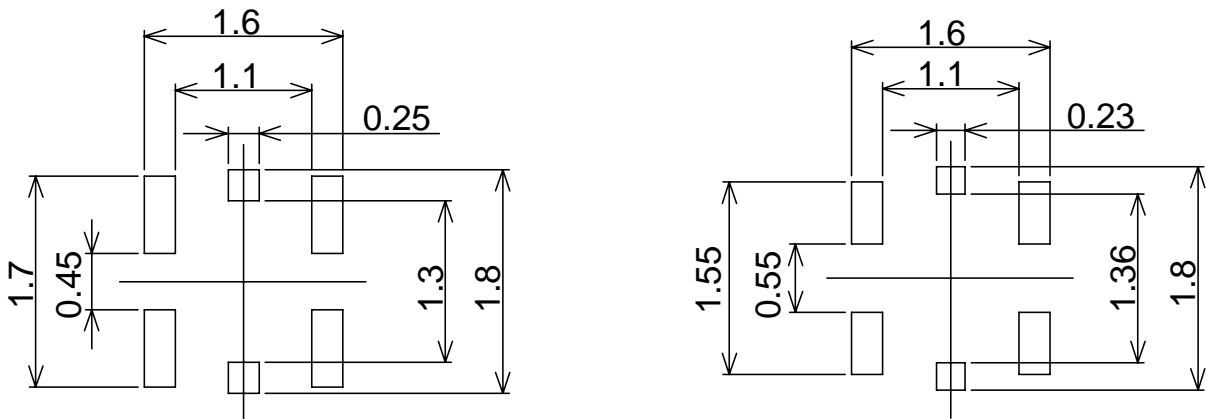

FIGURE3. Standard stencil mask pattern

6.  CAUTION

Limitation of Applications

Please do not use our products for the applications listed below which require specially high reliability for the prevention of defects which may directly or indirectly cause damage to the third party's life, body or property.

- (1) Aircraft equipment
- (2) Aerospace equipment
- (3) Undersea equipment
- (4) Power plant control equipment
- (5) Medical equipment
- (6) Transportation equipment (vehicles, trains, ships, etc.)
- (7) Traffic signal equipment
- (8) Disaster prevention / crime prevention equipment
- (9) Data-processing equipment
- (10) Application of similar complexity and/or reliability requirements to the applications listed in the above.

Mouser Electronics

Authorized Distributor

Click to View Pricing, Inventory, Delivery & Lifecycle Information:

[Murata:](#)

[MM8930-2620RJ4](#) [MM8930-2620RK15](#)