

PHILOSOPHY AND MISSION STATEMENT

ECS, Inc. International has over 100 years of combined experience in the manufacturing, testing and marketing of Frequency Control Products. We are proud of our progress because it has been driven by a strong desire to serve our customers. Our mission is to continue to provide excellence in products and worldwide technological support at competitive prices.

The central focus at ECS is to develop and strengthen business relationships with innovative original equipment manufacturers and other centers of technological excellence. Ongoing communication with our customers enables us to provide cost-effective solutions to product development needs that will help reduce time to market. Because these synergistic partnerships have proven successful, ECS has been chosen as a primary source to many of the world's leading electronic systems manufacturers.

Because of our broad product line, experience and commitment to the global marketplace, companies from the smallest to the world's largest, count on ECS for their frequency management requirements.

PRODUCTS

Quartz Crystal Components

Frequencies ranging from 15.0KHz to over 200 MHz are enclosed in various leaded and surface mount packages. These components meet or exceed requirements ranging from industrial/automotive applications to simplified timing requirements. Typical applications are: modems, PCMCIA cards, security and alarm systems, CATV interactive devices,

medical instrumentation, scanner/barcode equipment, telecommunications, Personal Digital Assistants and more.

Clock Oscillators

Frequencies ranging from 30KHz to over 150MHz are enclosed in various leaded and surface mount packages. These sophisticated hybrid Clock Oscillators meet or exceed requirements for applications such as cellular telecommunications, transmitting/receiving equipment, computer peripheral equipment, graphic boards, test instrumentation, local area networking (LAN), wireless communication systems and more.

- **TTL, HCMOS, PECL Output**
- **Enable/Disable Tri-State Function (optional)**
- **Temperature Compensated Crystal Oscillators (TCXO)**
- **Voltage Controlled Crystal Oscillators (VCXO)**

Monolithic Crystal Filters

Frequencies ranging from 10MHz to over 110.00MHz are enclosed in various leaded and surface mount packages. Superior inter-modulation, guaranteed attenuation and high reliability offer filtering requirements for all telecommunication applications.

Additional Product Offerings

- **Surface Acoustic Wave Devices (Resonators)**
- **Ceramic Devices (Resonators and Filters)**
- **Custom Frequencies/Custom Packaging**

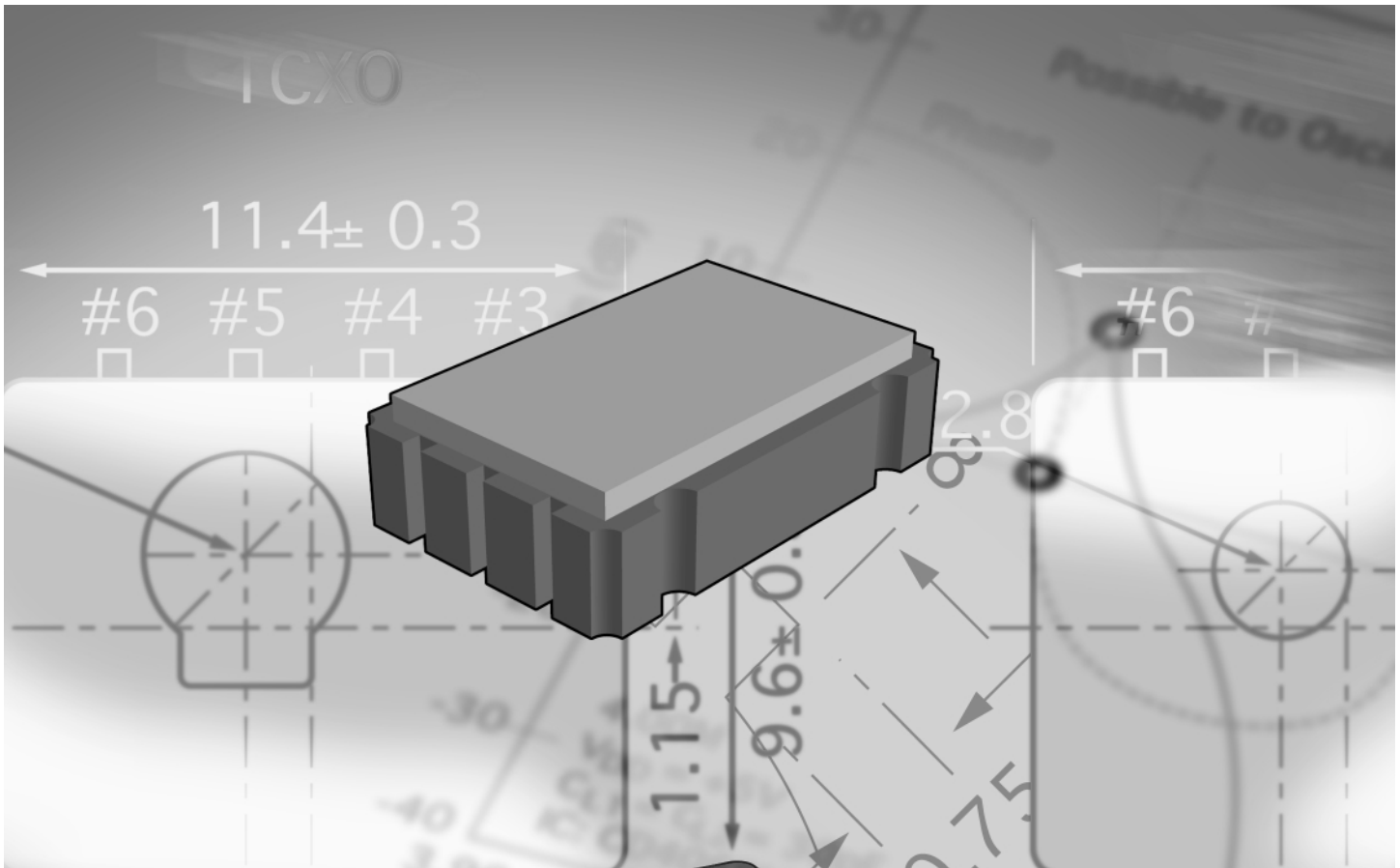

THRU-HOLE CRYSTALS

PRODUCT SELECTION MATRIX	2
ECS-3X8, 2X6, 1X5 TUNING FORK CRYSTALS	3
ECS-31 TUNING FORK CRYSTAL	4
HC-49U MICROPROCESSOR CRYSTALS	5
HC-49US MICROPROCESSOR CRYSTALS	6
UM-1, UM-5, UM-4 CRYSTALS	7
ECS-3X10, 3X9 CRYSTALS	8

SURFACE MOUNT CRYSTALS

PRODUCT SELECTION MATRIX	9
ECS-2X6-FL/1X5-FL SMD 32.768 KHZ CRYSTAL	10
ECX-205/206 SMD 32.768 KHZ CRYSTAL	11
ECX-306/306I SMD 32.768 KHZ CRYSTAL	12
ECX-3TA SMD 32.768 KHZ CRYSTAL	13
ECX-26/ECX-15 SMD 32.768 KHZ CRYSTAL	14
ECX-31 SMD 32.768 KHZ CRYSTAL	15
ECX-3S SMD CRYSTALS (12.5 x 4.6 x 3.7)	16
CSM-4A SMD QUARTZ CRYSTAL	17
CSM-7 SMD QUARTZ CRYSTAL	18
CSM-8 SMD CRYSTALS (7 x 5 x 1.7)	19
CSM-8M SMD CRYSTALS (7 x 5 x 1.2)	20
CSM-12 SMD CRYSTALS (11.8 x 5.5 x 2.5)	21
ECX-19A SMD QUARTZ CRYSTAL	22
ECX-64 SMD CRYSTALS (6 x 3.5 x 1.1)	23
ECX-64A/ECX-64C SMD QUARTZ CRYSTAL	24
ECX-53 SMD QUARTZ CRYSTAL	25
ECX-53B SMD QUARTZ CRYSTAL	26
ECX-32 SMD QUARTZ CRYSTAL	27
ECX-UM-1 SMD CRYSTAL	28
STANDARD CRYSTAL FREQUENCIES (Thru-hole and SMD)	29
QUARTZ CRYSTAL PRODUCT SELECTION AND PART NO. GUIDE	30

THRU-HOLE CLOCK OSCILLATORS

PRODUCT SELECTION MATRIX	31
ECS-100 SERIES TTL	32
ECS-200 SERIES HCMOS/TTL	33
ECS-400 SERIES HCMOS/TTL	34
ECS-1000 SERIES HCMOS/TTL, TRISTATE	35
ECS-2100 SERIES HCMOS/TTL, HALF-SIZE	36
ECS-2200 SERIES HCMOS/TTL, HALF-SIZE, TRISTATE	37
ECS-300C SERIES DUAL OUTPUT, 8-PIN DIP	38

SURFACE MOUNT CLOCK OSCILLATORS

PRODUCT SELECTION MATRIX	39
ECS-327SMO 32.768 KHZ (6.5 x 4 x 2)	40
ECS-8F SERIES HCMOS/TTL (14 x 9.8 x 4.7)	41
ECS-3951C/3953C SERIES HCMOS/TTL (7.5 x 5 x 1.6)	42
ECS-3955C SERIES HIGH LOAD (7.5 x 5 x 1.6)	43
ECS-3951M/3953M SERIES HCMOS/TTL (7.5 x 5 x 1.6)	44
ECS-3955M SERIES HIGH LOAD (7.5 x 5 x 1.6)	45
ECS-3961/3963 SERIES HCMOS/TTL (5.0 x 3.2 x 1.0)	46
CLOCK OSCILLATOR PRODUCT SELECTION GUIDE	47

PROGRAMMABLE CLOCK OSCILLATORS

PRODUCT SELECTION MATRIX	48
ECS-P53/ECS-P55 PROGRAMMABLE SMD CLOCK OSCILLATOR	49
ECS-P73/ECS-P75 PROGRAMMABLE SMD CLOCK OSCILLATOR	50
ECS-P83/ECS-P85 PROGRAMMABLE CLOCK OSCILLATOR	51
ECS-P143/ECS-P145 PROGRAMMABLE CLOCK OSCILLATOR	52

TCXO'S, VCXO'S

PRODUCT SELECTION MATRIX	53
ECS-500 SERIES TCXO, 14-PIN DIP	54
VC-TXO-39SM SMD VC-TCXO	55
VC-TXO-30SM SERIES SMD VC-TCXO	56
VC-TXO-35SM SERIES SMD VC-TCXO	57
ECS-VXO-11 SERIES 14-PIN DIP	58
ECS-VXO-143/ECS-VXO-83 SERIES SMD VCXO	59
ECS-VXO-73/ECS-VXO-75 SERIES SMD VCXO	60
ECS-VXO-97 SERIES SMD VCXO	61

RESONATORS: CERAMIC & SAW



PRODUCT SELECTION MATRIX	62
ZTA SERIES CERAMIC RESONATOR, THRU-HOLE	63
ZTT SERIES CERAMIC RESONATOR, THRU-HOLE	64
ECS-SR-A SMD CERAMIC RESONATOR	65
ECS-SR-B SMD CERAMIC RESONATOR	66
ECS-CR1/ECS-CR2A SMD CERAMIC RESONATOR	67
ECS-CR1/ECS-CR2B SMD CERAMIC RESONATOR	68
ZTB/ZTBF CERAMIC RESONATOR	69
ECS-DR1 SERIES ONE PORT SAW RESONATOR	70
ECS-DR2 SERIES TWO PORT 180° SAW RESONATOR	71
ECS-SDR1 SMD ONE PORT SAW RESONATOR	72



FILTERS: CRYSTAL & CERAMIC

PRODUCT SELECTION MATRIX	73
MONOLITHIC CRYSTAL FILTERS THRU-HOLE	74~76
ECS-96SMF SERIES SMD MCF	77
LTM450U 450 KHZ, 4 ELEMENT	78
LTM450W 450 KHZ, 6 ELEMENT	79
LTM455U 455 KHZ, 4 ELEMENT	80
LTM455W 455 KHZ, 6 ELEMENT	81
LPUB/LPZJL 455 KHz AM USE	82
LTE SERIES 4.5 ~ 6.5 MHz, BPF	83
XT SERIES 4.5 ~ 6.5 MHz, TRAP FILTER	84
L10.7 10.7 MHz CERAMIC BANDPASS FILTERS	85
ECS-D479.5B/ECS-D480A SAW FILTERS	86
ECS-DSF400.0A-51/ECS-DSF947.5-21 SAW FILTERS	87

TECHNICAL REFERENCES

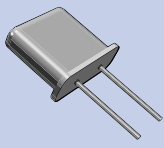
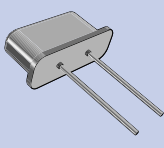
SECTION DIVIDER PAGE	88
QUARTZ CRYSTAL DESIGN PARAMETERS	89~91
CLOCK OSCILLATOR APPLICATION NOTES	92~94
OSCILLATION CIRCUIT DESIGN CONSIDERATIONS	95~98
CERAMIC RESONATOR PRINCIPLES	99~100
CERAMIC RESONATOR APPLICATIONS	101~105
FILTER APPLICATION NOTES	106~108
RELIABILITY TEST PROCEDURES	109~110
ORDERING INFORMATION	

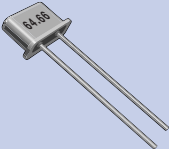
PRODUCT	ECS-3X8/2X6 ECS-1X5	ECS-31 SERIES	HC-49U	HC-49US
PRODUCT ILLUSTRATION				
FREQUENCY RANGE	32.768 KHz	20 ~ 200 KHz	1.80 ~ 200 MHz	3.57 ~ 70 MHz
FREQUENCY TOLERANCE @ +25°C	±20 PPM	±30 ~ 10,000 PPM	± 30 PPM	±30 PPM
FREQUENCY STABILITY	-0.04 PPM/°C ²	-0.034 PPM/°C ²	±50 PPM	±50 PPM
TEMPERATURE RANGE	-10 ~ +60°C	-10 ~ +60°C	-10 ~ +70°C	-10 ~ +70°C
FEATURES	<ul style="list-style-type: none"> • Tuning Fork Crystal • Cost Effective • Long-Term Stability • Tight Tolerances • Excellent Shock and Vibration Characteristics 	<ul style="list-style-type: none"> • Cost Effective • Miniature Size • Long-Term Stability • Excellent Shock and Vibration Characteristics 	<ul style="list-style-type: none"> • Cost Effective • Excellent Aging • Tight Tolerances Available • Wide Frequency Range • Industry Standard Footprint 	<ul style="list-style-type: none"> • Low Profile • Cost Effective • Excellent Aging • Wide Frequency Range • Excellent Reliability
PAGE #	3	4	5	6

PRODUCT	UM-1, UM-5 UM-4	ECS-3X10 ECS-3X9
PRODUCT ILLUSTRATION		
FREQUENCY RANGE	10 ~ 90 MHz	3.57 ~ 70 MHz
FREQUENCY TOLERANCE @ +25°C	±10 PPM	± 50 PPM
FREQUENCY STABILITY	±30 PPM	±50 PPM
TEMPERATURE RANGE	-30 ~ +80°C	-10 ~ +60°C
FEATURES	<ul style="list-style-type: none"> • Miniature Package • Excellent Aging • Tight Tolerances Available • Wide Frequency Range • Industry Standard Footprint 	<ul style="list-style-type: none"> • Cost Effective • Excellent Aging • Wide Frequency Range • Low Profile • Excellent Reliability
PAGE #	7	8

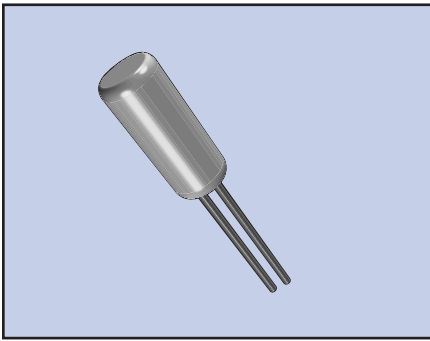

ECS tuning fork type crystals are used as a clock source in communication equipment, measuring instruments, microprocessors and other time management applications. Their low power consumption makes these crystals ideal for portable equipment.

FEATURES

- Cost effective
- Tight tolerance
- Long term stability
- Excellent resistance and environmental characteristics

PART NUMBERING GUIDE "EXAMPLE"

	FREQUENCY	LOAD CAPACITANCE	PACKAGE TYPE*
ECS	-.327	- 12.5	- 8
ECS	-.327	- 12.5	- 13
ECS	-.327	- 8	- 14

* Package type examples (8=3x8, 13=2x6, 14=1x5)

OPERATING CONDITIONS/ELECTRICAL CHARACTERISTICS

PARAMETERS		ECS-3X8	ECS-2X6	ECS-1X5	UNITS
NOMINAL FREQUENCY	F ₀	32.768	32.768	32.768	KHz
FREQUENCY TOLERANCE	Δf/f ₀	±20	±20	±20	PPM
LOAD CAPACITANCE (typ.)	C _L	12.5	12.5	8.0	pF
DRIVE LEVEL (max.)	D _L	1	1	1	μW
RESISTANCE AT SERIES RESONANCE	R ₁	35 (max.)	35 (max.)	40 (max.)	KΩ
Q-FACTOR	Q	90,000 (typ.)	70,000 (typ.)	80,000 (typ.)	
TURNOVER TEMPERATURE	T _M	+25 ±5	+25 ±5	+25 ±5	°C
TEMPERATURE COEFFICIENT	β	-0.040ppm/°C ² max.	-0.040ppm/°C ² max.	-0.040ppm/°C ² max.	PPM/(ΔC ²)
SHUNT CAPACITANCE	C ₀	1.60 (typ.)	1.35 (typ.)	1.00 (typ.)	pF
CAPACITANCE RATIO		460 (typ.)	450 (typ.)	400 (typ.)	
OPERATING TEMP. RANGE	T _{OPR}		-10~+60		°C
STORAGE TEMP. RANGE	T _{STG}		-40~+85		°C
SHOCK RESISTANCE		Drop test 3 times on hard wooden board from height of 75cm / ±5 PPM max.			PPM
INSULATION RESISTANCE	IR	500MΩ min./DC100V			MΩ
AGING (FIRST YEAR)	Δf/f ₀	±3 PPM max. @ +25°C ±3°C			PPM
MOTIONAL CAPACITANCE	C ₁	0.0035 (typ.)	0.0030 (typ.)	0.0025 (typ.)	pF

Note: Contact factory for optional load capacitance.

PACKAGE DIMENSIONS (mm)

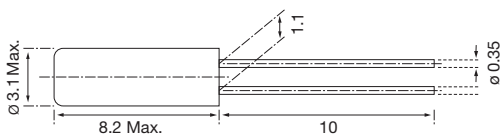

Figure 1) ECS-3X8

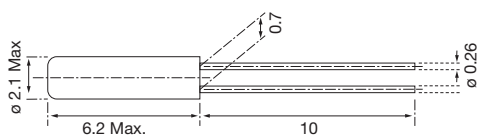

Figure 2) ECS-2X6

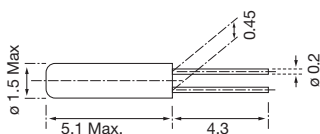
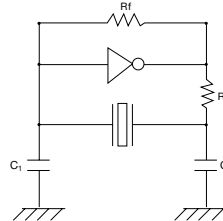

Figure 3) ECS-1X5

RECOMMENDED OSCILLATION CIRCUIT



ELECTRICAL CHARACTERISTICS

IC: TC 4069P
 Rf: 10MΩ
 Rd: 330KΩ (As required)
 C₁ = 22pF, C₂ = 22pF
 V_{DD} = 3.0V

In this circuit, low drive level with a maximum of 1μW is recommended. If excessive drive is applied, irregular oscillation or quartz element fractures may occur.

PARABOLIC TEMPERATURE CURVE

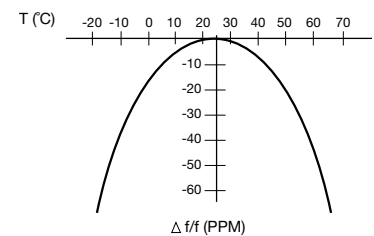

To determine frequency stability, use parabolic curvature. For example: What is the stability at 45°C?

- 1) Change in T (°C) = 45 - 25 = 20°C
- 2) Change in frequency = -0.04 PPM x (ΔT)²
 = -0.04 PPM x (20)²
 = -16.0 PPM

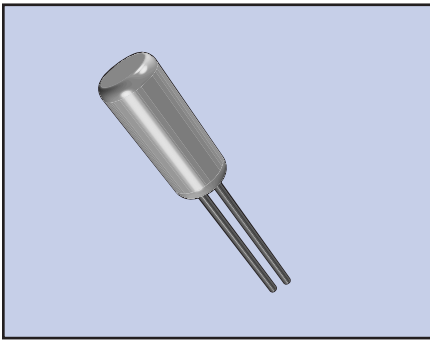

The ECS-31 Series features the same characteristics as only tuning fork crystals offer. Because of their miniature size they are ideal for portable and communication equipment applications.

FEATURES

- Miniature size
- Cost effective
- Long term stability
- Excellent shock and vibration characteristics

PART NUMBERING GUIDE "EXAMPLE"

MANUFACTURER	FREQUENCY	LOAD CAPACITANCE	PACKAGE TYPE*
ECS	.400	12.5	8
ECS	.400	12.5	13
ECS	2.0	12.5	14

* Package type examples (8=3x8, 13=2x6, 14=1x5)

OPERATING CONDITIONS/ELECTRICAL CHARACTERISTICS

PARAMETERS		3X8	2X6	1X5	CONDITIONS
FREQUENCY RANGE	f_0	20KHz ~ 40KHz	30KHz ~ 150KHz	200KHz	KHz
FREQUENCY TOLERANCE	$\Delta f/f_0$	± 30 PPM	± 30 PPM	$\pm 10,000$ PPM	@ +25°C
FREQUENCY VS. TEMP. CHARAC.	$\Delta f/f_0$		See Drawing		-10°C ~ +60°C
TURNOVER TEMPERATURE	T_m		+25°C typ.		
TEMPERATURE COEFFICIENT	β		-0.034 PPM/°C ² typ.		Varies depending on frequency
OPERATING TEMP. RANGE	T_{OPR}		-10 ~ +60		°C
STORAGE TEMP. RANGE	T_{STG}		-40 ~ +85		°C
EQUIVALENT SERIES RESISTANCE	R_1		30 ~ 50 (max.)	10 (max.)	KΩ
LOAD CAPACITANCE	C_L		12.5pF typ. (Customer Specified)		pF
MOTIONAL CAPACITANCE	C_1		1 ~ 4fF typ.		fF
SHUNT CAPACITANCE	C_0		0.8 ~ 1.7pF typ.		pF
CAPACITANCE RATIO	τ		425 ~ 800 typ.		
DRIVE LEVEL	DL		1μW max.		μW
INSULATION RESISTANCE	IR		500 MΩ min.		DC 100V±15
AGING (FIRST YEAR)	$\Delta f/f_0$		± 5 PPM max.		+25°C ± 3°C
SHOCK RESISTANCE		± 5 PPM max. Drop test of 3 times on a hard board from 75 cm height or shock test of 3000G x 0.3ms x 1/2 sin wave x 3 directions			Conditions will vary depending on frequency

PACKAGE DIMENSIONS (mm)

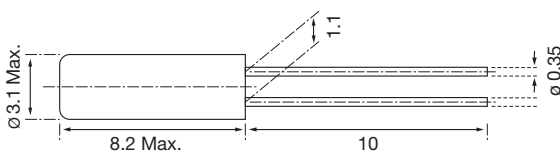

Figure 1) ECS-31-8

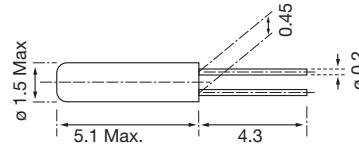

Figure 3) ECS-31-14

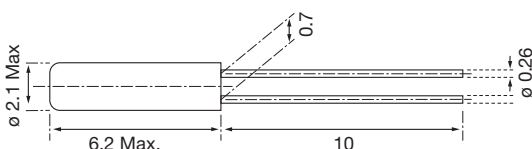
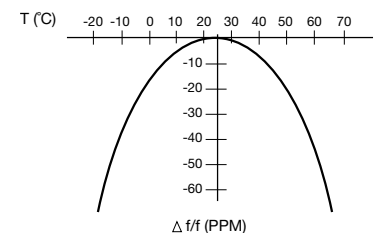

Figure 2) ECS-31-13

PARABOLIC TEMPERATURE CURVE



To determine frequency stability, use parabolic curvature. For example: What is the stability at 45°C?

- 1) Change in T (°C) = 45 - 25 = 20°C
- 2) Change in frequency = $-0.04 \text{ PPM} \times (\Delta T)^2$
 $= -0.04 \text{ PPM} \times (20)^2$
 $= -16.0 \text{ PPM}$

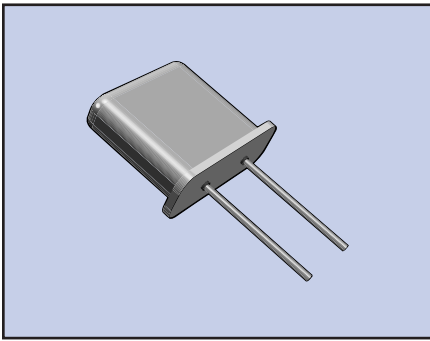

This product represents our selection of standard resistance weld type quartz crystals.

- OPTIONS:
- extended temperature range
 - pullability
 - mylar spacer
 - vinyl sleeve
 - third ground lead
 - radial Tape and Reel (1,000 pcs)

FEATURES

- Cost effective
- Excellent aging
- Wide frequency range
- Tight tolerances
- Excellent reliability
- "AT" cut crystal

PART NUMBERING GUIDE "EXAMPLE"

ECS	FREQUENCY (16.000 MHz)	LOAD CAPACITANCE*	PACKAGE TYPE
-	160	20	1

* Load capacitance (xx=xx pF, S= series resonance)
 Note: See Product Selection Guide for additional options.

OPERATING CONDITIONS/ELECTRICAL CHARACTERISTICS

PARAMETERS	CONDITIONS	MINIMUM	MAXIMUM	UNITS
FREQUENCY RANGE	f_0	1.800	200.000	MHz
FREQUENCY TOLERANCE	Ref @ +25°C	-30	+30	PPM
FREQUENCY STABILITY	Ta=-10°C ~ +70°C	-50	+50	PPM
OPERATING TEMPERATURE	T _{OPR}	-10	+70	°C
STORAGE TEMPERATURE	T _{STG}	-30	+85	°C
SHUNT CAPACITANCE	C ₀		7.0	pF
LOAD CAPACITANCE	C _L (Customer Specified)	10.0	Series	pF
DRIVE LEVEL	1.800 ~ 3.000MHz, 3.000 ~ 200.000MHz		2.0, 1.0	mW
AGING (FIRST YEAR)	@ +25°C	-5.0	+5.0	PPM

EQUIVALENT SERIES RESISTANCE / MODE OF OSCILLATION

FREQUENCY RANGE (MHz)	MODE	MAX ESR Ω	FREQUENCY RANGE (MHz)	MODE	MAX ESR Ω
1.800 ~ 1.999	Fundamental	750	5.000 ~ 5.999	Fundamental	50
2.000 ~ 2.399	Fundamental	500	6.000 ~ 7.999	Fundamental	40
2.400 ~ 2.999	Fundamental	300	8.000 ~ 9.999	Fundamental	35
3.000 ~ 3.199	Fundamental	200	10.000 ~ 12.499	Fundamental	30
3.200 ~ 3.699	Fundamental	120	12.500 ~ 15.999	Fundamental	25
3.700 ~ 4.199	Fundamental	100	16.000 ~ 25.000	Fundamental	20
4.200 ~ 4.899	Fundamental	70	23.000 ~ 100.000	3rd O/T	40
4.900 ~ 4.999	Fundamental	55			

PACKAGE DIMENSIONS (mm)

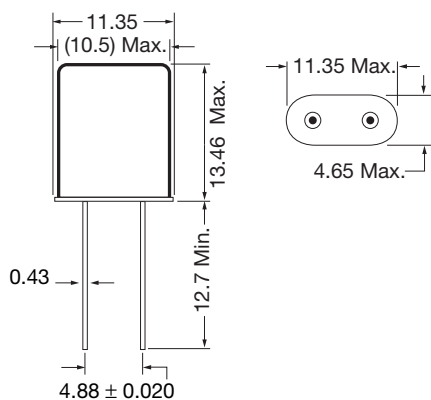

Figure 1) HC-49U - Side and Bottom views

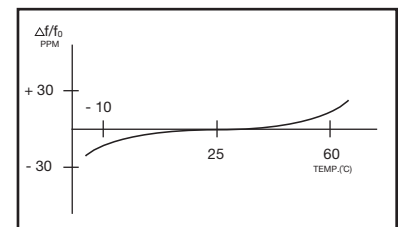
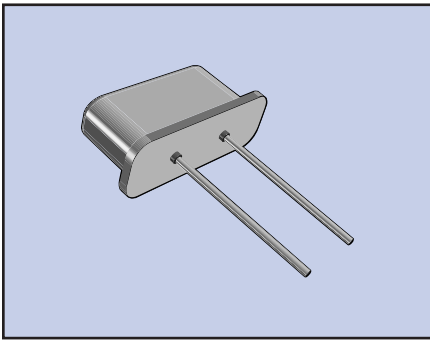

Figure 2) Frequency vs Temperature Curve



This product represents our selection of low profile resistance weld type quartz crystals.

- OPTIONS:**
- extended temperature range
 - tighter tolerances
 - mylar spacer
 - 3rd in line lead base
 - radial tape and reel (1,000 pcs)

FEATURES

- Cost effective
- Excellent aging
- Wide frequency range
- Low profile
- Excellent reliability
- "AT strip" blank technology

PART NUMBERING GUIDE "EXAMPLE"

ECS	FREQUENCY (16.0000 MHz)	LOAD CAPACITANCE*	PACKAGE TYPE**
-	160	20	4

* Load capacitance (xx=xx pF, S= series resonance), ** Package Type examples (4= 3.5mm max. height, 4L= 2.5mm max. height)
 For extended temp range of -40 to +85°C ad -DN suffix for example ECS-160-20-4-DN
 Note: See Product Selection Guide for additional options.

OPERATING CONDITIONS/ELECTRICAL CHARACTERISTICS

PARAMETERS	CONDITIONS	MINIMUM	MAXIMUM	UNITS
FREQUENCY RANGE	f_0	3.57	70.000	MHz
FREQUENCY TOLERANCE	@ +25°C		±30	PPM
FREQUENCY STABILITY, ref @ 25°C	Standard -10 ~ +70°C		±50	PPM
	"DN" Option -40 ~ +85°C		±100	PPM
OPERATING TEMPERATURE	Standard	-10	+70	°C
	DN option	-40	+85	°C
STORAGE TEMPERATURE		-40	+105	°C
SHUNT CAPACITANCE	C_0		7.0	pF
LOAD CAPACITANCE	C_L (Customer Specified)	10.0	Series	pF
DRIVE LEVEL	3.57 ~ 70.000MHz		0.5	mW
AGING (FIRST YEAR)	@ +25°C		±5.0	PPM

EQUIVALENT SERIES RESISTANCE / MODE OF OSCILLATION

FREQUENCY RANGE (MHz)	MODE	MAX ESR Ω	FREQUENCY RANGE (MHz)	MODE	MAX ESR Ω
3.570 ~ 3.999	Fundamental	200	9.000 ~ 12.999	Fundamental	60
4.000 ~ 4.999	Fundamental	150	13.000 ~ 19.999	Fundamental	40
5.000 ~ 5.999	Fundamental	120	20.000 ~ 30.000	Fundamental	30
6.000 ~ 6.999	Fundamental	100	27.000 ~ 70.000	3rd O/T	100
7.000 ~ 8.999	Fundamental	80			

PACKAGE DIMENSIONS (mm)

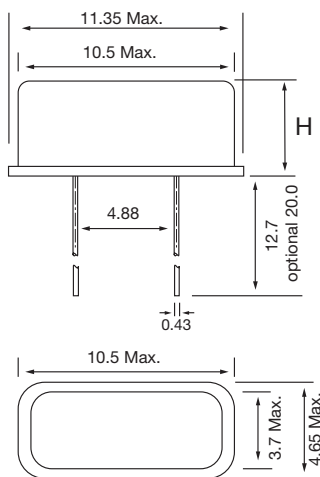

Height "H" (max.)	
-4	3.5 mm
-4L	2.5 mm

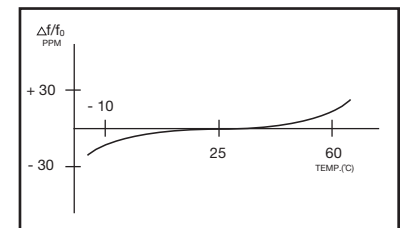
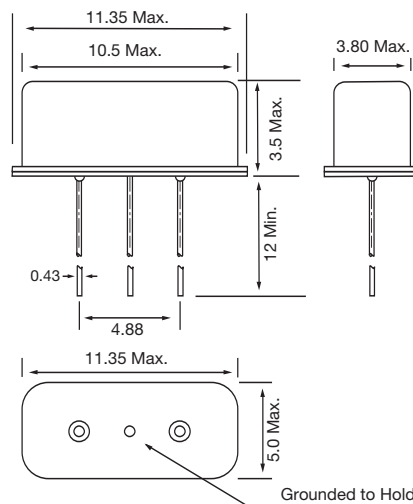
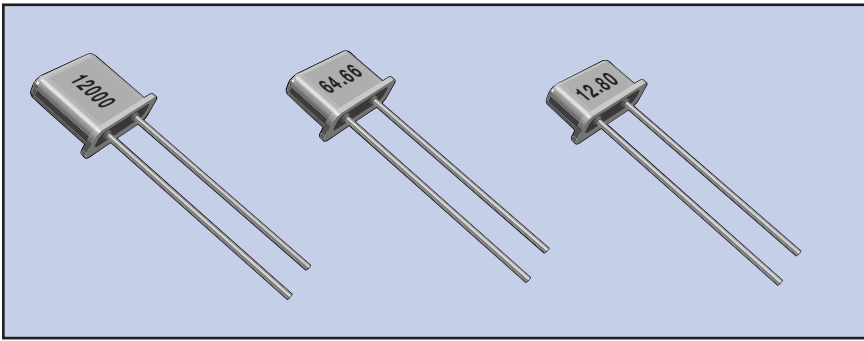

Figure 3) Frequency vs Temperature Curve

Figure 1) HC-49US - Top and Side views

Figure 2) HC-49US - 3rd In Line Lead Base - Side & Bottom View



FEATURES

- Cost effective
- Excellent aging
- Wide frequency range
- Low profile
- Excellent reliability
- Tape and Reel (1,000 pcs)

ECS's UM-1, 5, 4 quartz crystals are ideal for use in compact communication equipment.

PART NUMBERING GUIDE "EXAMPLE"

ECS	FREQUENCY (16.0000 MHz)	LOAD CAPACITANCE*	PACKAGE TYPE**
-	160	20	22

* Load capacitance (xx=xx pF, S= series resonance), ** Package Type examples (22 = UM-1, 21= UM-5, 25 = UM-4)
 Note: See Product Selection Guide for additional options.

OPERATING CONDITIONS/ELECTRICAL CHARACTERISTICS

PARAMETERS	UM-1	UM-5	UM-4
FREQUENCY RANGE	FUNDAMENTAL 3RD OVERTONE	10.000 ~ 30.000 MHz 25.000 ~ 90.000 MHz	30.000 ~ 90.000 MHz
FREQUENCY TOLERANCE (@ +25°C)			See Table 1
FREQUENCY-TEMPERATURE TOLERANCE (@ +25°C)			See Table 2
OPERATING TEMPERATURE RANGE T _{OPR}			See Table 2
STORAGE TEMPERATURE RANGE T _{STG}			-40 ~ +90°C
LOAD CAPACITANCE (C _L)		10pF – Series (Customer Specified)	
SHUNT CAPACITANCE (C ₀)		7 pF max.	
DRIVE LEVEL (D _L)		500 μW max.	
CRYSTAL CUT		AT-cut	

TABLE 1 FREQUENCY TOLERANCE (@ +25°C)

Tolerance (x 10 ⁻⁶)					
±10	±15	±20	±30	±50	
●	●	○	○	○	● recommended ○ available

TABLE 2 FREQUENCY-TEMPERATURE TOLERANCE (@ +25°C)

FREQUENCY	Tolerance (x 10 ⁻⁶)						
	±3.0	±5.0	±7.5	±10	±15	±20	±30
0 ~ +50°C	○	○	○	○			
-10 ~ +60°C		○	○	●	○		
-20 ~ +70°C			○	○	○	○	
-30 ~ +75°C					○	○	○
-30 ~ +80°C					○	○	●
-35 ~ +80°C						○	○
-40 ~ +85°C						○	○

TABLE 3 EQUIVALENT SERIES RESISTANCE / MODE OF OSCILLATION

NOMINAL FREQUENCY (MHz)	MODE	ESR (Ω)	
		UM-1	UM-5, UM-4
10 ~ 15	FUNDAMENTAL	40 max.	50 max.
15 ~ 30	FUNDAMENTAL	25 max.	30 max.
25 ~ 30	3rd	50 max.	60 max.
30 ~ 90	3rd	45 max.	60 max.

PACKAGE DIMENSIONS (mm)

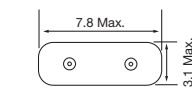
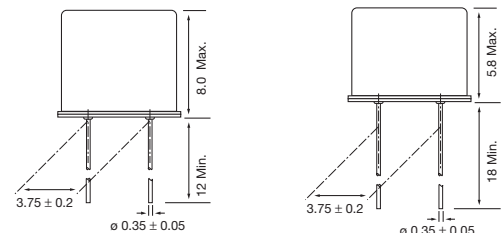

Figure 1) UM-1 Crystal Unit Side and Bottom view

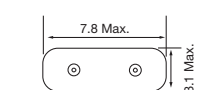
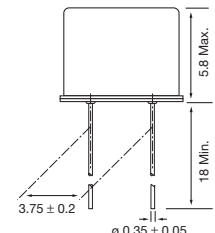

Figure 2) UM-5 Crystal Unit Side and Bottom view

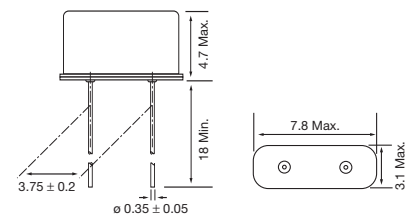
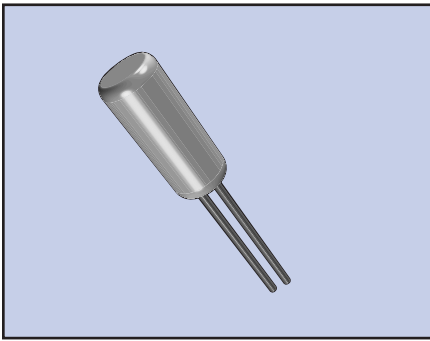

Figure 3) UM-4 Crystal Unit Side and Bottom view



These products represent our selection of miniature tubular high frequency crystals. They feature outstanding shock/vibration resistance and environmental characteristics.

FEATURES

- Cost effective
- Excellent aging
- Wide frequency range
- Excellent reliability

PART NUMBERING GUIDE "EXAMPLE"

		FREQUENCY		LOAD CAPACITANCE*		PACKAGE TYPE**
ECS	-	35	-	16	-	10
ECS	-	160	-	16	-	9

* Load capacitance (xx=xx pF, S= series resonance), ** Package Type examples (10 = 3x10, 9 = 3x9)

OPERATING CONDITIONS/ELECTRICAL CHARACTERISTICS

PARAMETERS		ECS-3x10	ECS-3x9	CONDITIONS
FREQUENCY RANGE	f_0	3.5MHz ~ 4MHz	4MHz ~ 30MHz (fund), 30MHz ~ 70MHz (3rd OT)	
FREQUENCY TOLERANCE	$\Delta f/f_0$	±50 PPM		@ +25°C
FREQUENCY VS. TEMP. CHARAC.	$\Delta f/f_0$	±50 PPM		-10°C ~ +60°C
OPERATING TEMPERATURE RANGE	T_{OPR}	-10 ~ +60		°C
STORAGE TEMP. RANGE	T_{STG}	-40 ~ +85		°C
EQUIVALENT SERIES RESISTANCE	R_1	See table		
LOAD CAPACITANCE	C_L	16.0 pF typ. (Customer Specified)		pF
SHUNT CAPACITANCE	C_0	5.0 max.		pF
DRIVE LEVEL	D_L	50µW ~ 100µW		µW
INSULATION RESISTANCE	IR	500MΩ min.		DC 100V ±15V
AGING (FIRST YEAR)	$\Delta f/f_0$	±5 PPM max.		25°C ±3°C
SHOCK RESISTANCE		±5 PPM Drop test of 3 times on a hard board from 75 cm height or shock test of 3000G x 0.3ms x 1/2 sin wave x 3 directions		Conditions will vary depending on frequency

EQUIVALENT SERIES RESISTANCE/ MODE OF OSCILLATION

FREQUENCY MHz	EQUIVALENT SERIES RESISTANCE	MODE
3.5MHz ~ 4MHz	200 Ω MAX.	Fundamental
4MHz ~ 6MHz	150 Ω MAX.	
6MHz ~ 10MHz	100 Ω MAX.	
10MHz ~ 30MHz	50 Ω MAX.	
30MHz ~ 36MHz	100 Ω MAX.	3rd O/T
36MHz ~ 70MHz	80 Ω MAX.	

PACKAGE DIMENSIONS (mm)

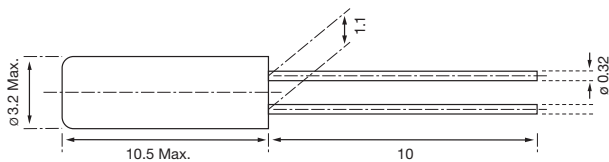

Figure 1) ECS-3x10

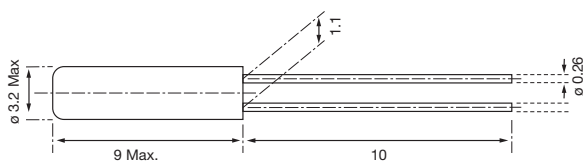

Figure 2) 3x9

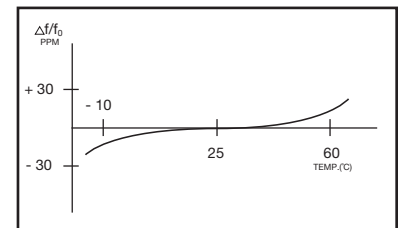
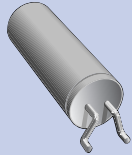
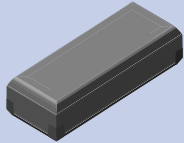
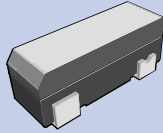
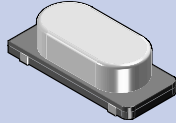
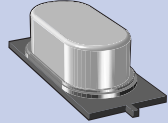
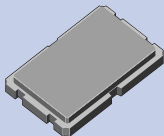
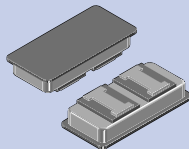
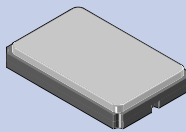
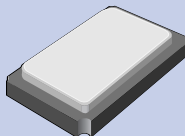
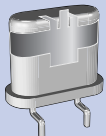
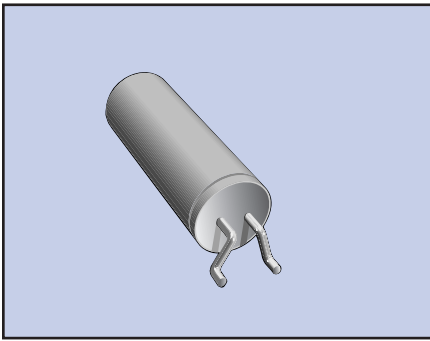

Figure 3) Frequency vs Temperature Curve

PRODUCT	ECS-2X6-FL/1X5-FL	ECX-205/206, ECX-306 ECX-3TA, ECX-26/15, ECX-31	ECX-3S	CSM-4A	CSM-7
PRODUCT ILLUSTRATION					
FREQUENCY RANGE	32.768 KHz	32.768 KHz	3.57 ~ 70 MHz	3.57 ~ 70 MHz	3.57 ~ 70 MHz
FREQUENCY TOLERANCE @ +25°C	±30 PPM	±20	±30 PPM	±30 PPM	±30 PPM
FREQUENCY STABILITY	-0.04 PPM/°C ²	-0.04 PPM/°C ²	±50PPM	±50 PPM	±50 PPM
TEMPERATURE RANGE	-10 ~ +860°C	-10 ~ +50°C	-10 ~ +70°C	-10 ~ +70°C	-10 ~ +70°C
FEATURES	<ul style="list-style-type: none"> • Tuning Fork Crystal • Long-Term Stability • Formed Lead Version • Cost Effective 	<ul style="list-style-type: none"> • Tuning Fork Crystal • 2 mm Profile Version • Tight Tolerances • Tape and Reel 	<ul style="list-style-type: none"> • Low Profile • Industry Std. Footprint • High Temperature Seal • Tape and Reel 	<ul style="list-style-type: none"> • Cost Effective • Space Saving Design • Standard Footprint 	<ul style="list-style-type: none"> • Low Profile • Space Saving Design • Cost Effective • Standard Footprint
PAGE #	10	11-15	16	17	18

PRODUCT	CSM-8, CSM-8M	CSM-12, CSM-19A	ECX-64, ECX-64A/64C	ECX-53, ECX-53B ECX-32	ECX-UM-1
PRODUCT ILLUSTRATION					
FREQUENCY RANGE	8.0 ~ 100 MHz	3.57 ~ 30 MHz	12 ~ 100 MHz	12 ~ 100 MHz	3.7 ~ 225 MHz
FREQUENCY TOLERANCE @ +25°C	±30 PPM	±30 PPM	±30 PPM	±50 PPM	±50 ~ ±100 PPM
FREQUENCY STABILITY	±50 PPM	±50 PPM	±50 PPM	±50 PPM	±50 ~ ±100 PPM
TEMPERATURE RANGE	-10 ~ +70°C	-10 ~ +70°C	-10 ~ +70°C	-10 ~ +70°C	-10 ~ +60°C
FEATURES	<ul style="list-style-type: none"> • 1.5 mm Profile Version • Seam Welded Option • Excellent Aging 	<ul style="list-style-type: none"> • 2.5 or 2.0 mm Profile • Tape & Reel • High Reliability 	<ul style="list-style-type: none"> • 1.1 mm Profile • Wide Frequency Range • Excellent Aging • Miniature Design 	<ul style="list-style-type: none"> • 1.1 mm Profile • Sub Miniature Package • Excellent Aging 	<ul style="list-style-type: none"> • Low Profile • Small Footprint • Excellent Aging • Tight Tolerance
PAGE #	19-20	21-22	23-24	25-27	28



The ECS-2X6-FL and ECS-1X5-FL are pre-formed lead configured crystals for use in surface mount requirements. Both packages offer a cost effective solution over other SMD versions.

FEATURES

- Long term stability
- Cost effective
- SMD version
- Tape & Reel

PART NUMBERING GUIDE "EXAMPLE"

	FREQUENCY	LOAD CAPACITANCE	PACKAGE TYPE*
ECS	- .327	- 12.5	- 13 FL
ECS	- .327	- 12.5	- 14 FL

* Package Type examples (-13FL= 2x6-FL, -14FL= 1x5-FL)

OPERATING CONDITIONS/ELECTRICAL CHARACTERISTICS

PARAMETERS	CONDITIONS	ECX-2X6-FL			ECX-1X5-FL			UNITS
		MIN	TYP	MAX	MIN	TYP	MAX	
NORMAL FREQUENCY	Fo		32.768			32.768		KHz
FREQUENCY TOLERANCE				±20			±20	PPM
TURNOVER TEMPERATURE		+20	+25	+30	+20	+25	+30	°C
OPERATING TEMP RANGE	Topr	-40		+85	-40		+85	°C
STORAGE TEMP RANGE	Tstg	-55		+125	-55		+125	°C
EQUIVALENT SERIES RESISTANCE	ESR			50			55	KΩ
INSULATION RESISTANCE	100 V DC ± 15 V	500M			500M			Ω
DRIVE LEVEL	DL			1.0			1.0	μW
AGING (FIRST YEAR)	25°C ± 3°C			±5			±3	PPM
VIBRATION RESISTANCE				±5			±10	PPM
SHOCK RESISTANCE				±5			±10	PPM
CAPACITANCE RATIO	Co/C1		450			420		
SHUNT CAPACITANCE	Co		1.35			0.8		pF
TEMPERATURE COEFFICIENT				-0.04			-0.04	ppm/°C ²
Q FACTOR		50K	70K			80K		
LOAD CAPACITANCE	CL		12.5			12.5		pF
MOTIONAL CAPACITANCE	C1		0.003			0.0019		pF

PACKAGE DIMENSIONS (mm)

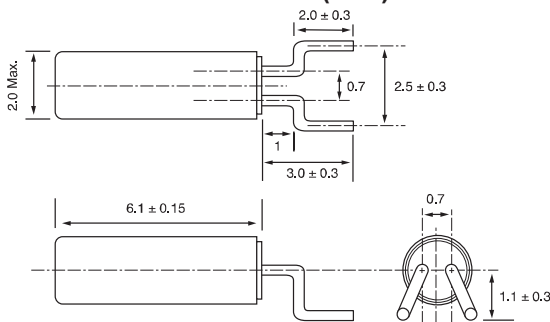

Figure 1) ECS-2X6-FL - Top, Side and End views

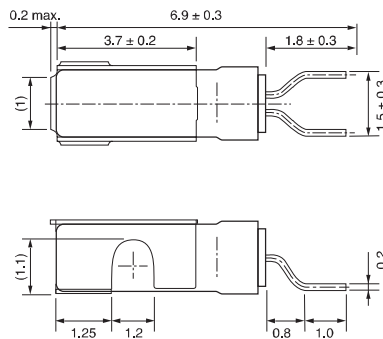

Figure 1) ECS-1X5-FL - Top, Side and End views

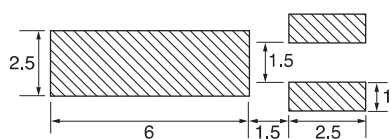

Figure 2) ECS-2X6-FL Land Pattern - Top view

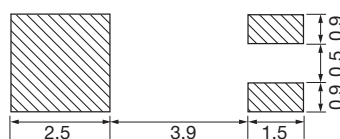
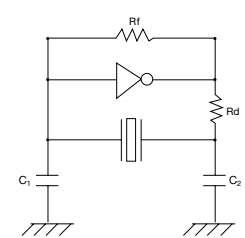

Figure 4) ECS-1X5-FL Land Pattern - Top view

RECOMMENDED OSCILLATION CIRCUIT



ELECTRICAL CHARACTERISTICS

IC: TC 4069P

Rf: 10MΩ

Rd: 330KΩ (As required)

C₁ = 22pF, C₂ = 22pF

V_{DD} = 3.0V

In this circuit, low drive level with a maximum of 1μW is recommended. If excessive drive is applied, irregular oscillation or quartz element fractures may occur.

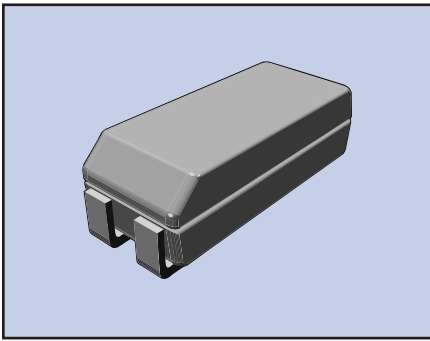

Housing for the ECX-205/206 crystal is made from the same thermoplastic that is industry standard for integrated circuits. This ruggedized molded package is excellent for SMD applications.

FEATURES

- Low profile
- Long term stability
- Industry standard footprint
- Tape and Reel (2,000 pcs)

PART NUMBERING GUIDE "EXAMPLE"

	FREQUENCY	LOAD CAPACITANCE	PACKAGE TYPE*
ECS	-.327	- 12.5	- 11
ECS	-.327	- 12.5	- 6

* Package Type examples (11= ECX-205, 6= ECX-206)

OPERATING CONDITIONS/ELECTRICAL CHARACTERISTICS

PARAMETERS		ECX-205/206	UNITS
NOMINAL FREQUENCY	F ₀	32.768	KHz
LOAD CAPACITANCE	C _L	12.5 Standard (6.0 Optional)	pF
DRIVE LEVEL	D _L	1.0 max.	μW
CALIBRATION TOLERANCE	@ +25°C	±20	PPM
EQUIVALENT SERIES RESISTANCE	R ₁	50 max.	K Ω
TEMPERATURE COEFFICIENT		-0.040 PPM/°C ² max.	PPM/(ΔC°)
OPERATING TEMPERATURE RANGE	T _{OPR}	-10 ~ +60	°C
MAX. OPERATING TEMPERATURE RANGE		-40 ~ +85	°C
Q FACTOR	Q	50,000 min.	
TURNOVER TEMPERATURE	T ₀	+25 ± 5	°C
STORAGE TEMPERATURE RANGE	T _{STG}	-55 ~ +125	°C
INSULATION RESISTANCE	IR	500MΩ min./ DC 100V	MΩ
SHUNT CAPACITANCE	C ₀	2.0 typical	pF
MOTIONAL CAPACITANCE	C ₁	0.003 pF typical	pF
AGING (FIRST YEAR)	Δf/f ₀	±3 PPM max. @ +25°C	PPM

PACKAGE DIMENSIONS (mm)

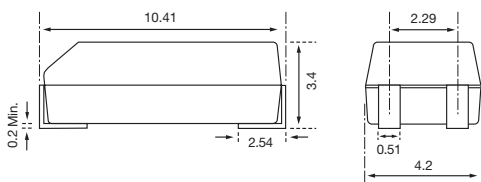

Figure 1) ECX-205/206 - Side and End views

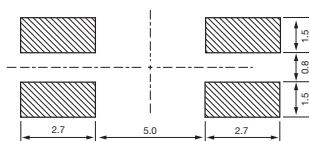

Figure 2) ECX-205/206 Land Pattern- Top view

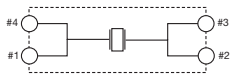

Figure 3) ECX-205 Pin Connection - Top view

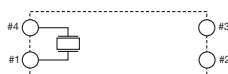
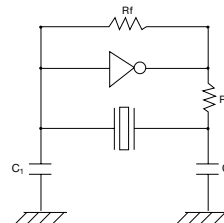

Figure 4) ECX-206 Pin Connection - Top view

RECOMMENDED OSCILLATION CIRCUIT



ELECTRICAL CHARACTERISTICS

IC: TC 4069P
 R_f: 10MΩ
 R_d: 330KΩ (As required)
 C₁ = 22pF, C₂ = 22pF
 V_{DD} = 3.0V

In this circuit, low drive level with a maximum of 1μW is recommended. If excessive drive is applied, irregular oscillation or quartz element fractures may occur.

PARABOLIC TEMPERATURE CURVE

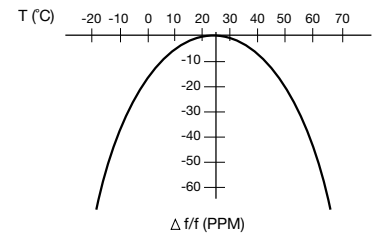

To determine frequency stability, use parabolic curvature. For example: What is the stability at 45°C?

- 1) Change in T (°C) = 45 - 25 = 20°C
- 2) Change in frequency = -0.04 PPM x (ΔT)²
 = -0.04 PPM x (20)²
 = -16.0 PPM

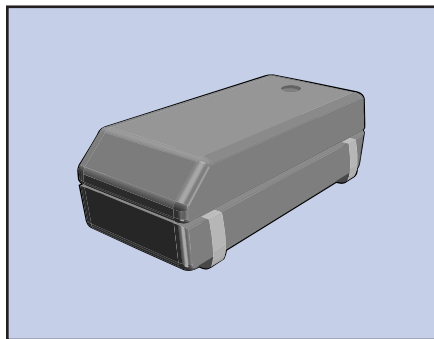

Housing for the ECX-306/306I crystal is made from the same thermoplastic that is industry standard for integrated circuits. This ruggedized molded package is excellent for SMD applications.

FEATURES

- Low profile
- Long term stability
- Industry standard footprint
- Excellent shock resistance
- Excellent environmental characteristics
- Tape and Reel (3,000 pcs)

PART NUMBERING GUIDE "EXAMPLE"

ECS	FREQUENCY	LOAD CAPACITANCE	PACKAGE TYPE**
-	.327	- 12.5	- 17

** Package Type examples (-17= ECX-306, 17I= ECX-306I)

OPERATING CONDITIONS/ELECTRICAL CHARACTERISTICS

PARAMETERS		ECX-306/306I	UNITS
NOMINAL FREQUENCY	F ₀	32.768	KHz
LOAD CAPACITANCE	C _L	12.5 Standard (6.0 Optional)	pF
DRIVE LEVEL	D _L	1 max.	μW
CALIBRATION TOLERANCE	@ 25°C	±20	PPM
EQUIVALENT SERIES RESISTANCE	R ₁	50 max.	KΩ
TEMPERATURE COEFFICIENT		-0.040 PPM/°C ² max.	PPM/(Δ°C)
OPERATING TEMPERATURE RANGE	T _{OPR}	-10 ~ +60	°C
MAX. OPERATING TEMPERATURE RANGE		-40 ~ +85	°C
Q FACTOR	Q	50,000 min.	
TURNOVER TEMPERATURE	T ₀	+25 ± 5	°C
STORAGE TEMPERATURE RANGE	T _{STG}	-55 ~ +125	°C
INSULATION RESISTANCE	IR	500MΩ min./ DC 100V	MΩ
SHUNT CAPACITANCE	C ₀	1.35 typical	pF
MOTIONAL CAPACITANCE	C ₁	0.003 pF typical	pF
AGING (FIRST YEAR)	Δf/f ₀	±3 PPM max. @ +25°C	PPM

PACKAGE DIMENSIONS (mm)

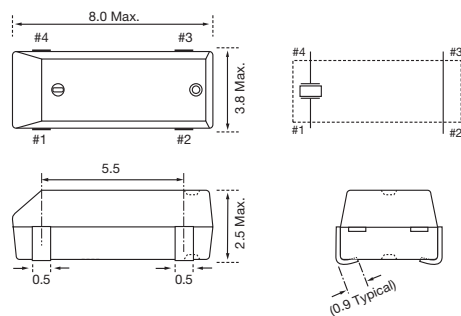

Figure 1) ECX-306 - Top, Side and End views with pin connections

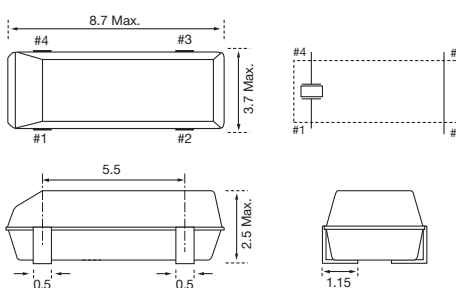

Figure 2) ECX-306I - Top, Side and End views with pin connections

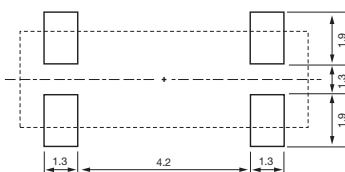
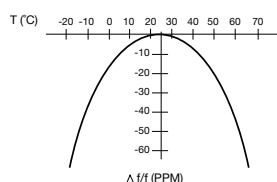

Figure 3) ECX-306/306I Land Pattern - Top view

PARABOLIC TEMPERATURE CURVE



To determine frequency stability, use parabolic curvature. For example:
 What is the stability at 45°C?
 1) Change in T (°C) = 45 - 25 = 20°C
 2) Change in frequency = -0.04 PPM x (ΔT)²
 = -0.04 PPM x (20)²
 = -16.0 PPM

RECOMMENDED OSCILLATION CIRCUIT

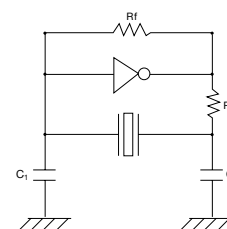

ELECTRICAL CHARACTERISTICS

IC: TC 4069P
 R_f: 10MΩ
 R_d: 330KΩ (As required)
 C₁ = 22pF, C₂ = 22pF
 V_{DD} = 3.0V

In this circuit, low drive level with a maximum of 1μW is recommended. If excessive drive is applied, irregular oscillation or quartz element fractures may occur.

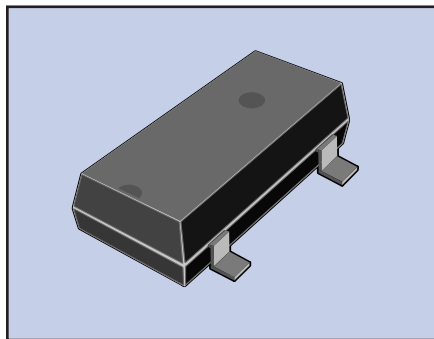

The ECX-3TA is a 2.0 mm low profile ruggedized thermoplastic molded 32.768KHz SMD tuning fork crystal. This crystal is excellent for SMD applications with limited circuit board space requirements.

FEATURES

- Low profile 2.0 mm maximum height
- Industry standard footprint
- Long term stability
- Excellent shock resistance
- Excellent environmental characteristics
- Tape & Reel (3,000 pcs)

PART NUMBERING GUIDE "EXAMPLE"

MANUFACTURER	FREQUENCY	LOAD CAPACITANCE	PACKAGE TYPE
ECS	- .327	- 12.5	- 24

OPERATING CONDITIONS/ELECTRICAL CHARACTERISTICS

PARAMETERS	ECX-3TA	UNITS
NOMINAL FREQUENCY	F ₀	32.768 KHz
LOAD CAPACITANCE	C _L	12.5 Standard (6.0 Optional) pF
DRIVE LEVEL	D _L	1.0 max. μW
CALIBRATION TOLERANCE	@ +25°C	±20 PPM
EQUIVALENT SERIES RESISTANCE	R ₁	50 max. K Ω
TEMPERATURE COEFFICIENT		-0.040 PPM/°C ² max.
OPERATING TEMPERATURE RANGE	T _{OPR}	-10 ~ +60 °C
MAX. OPERATING TEMPERATURE RANGE		-40 ~ +85 °C
Q FACTOR	Q	50,000 min.
TURNOVER TEMPERATURE	T ₀	+25 ± 5 °C
STORAGE TEMPERATURE RANGE	T _{STG}	-55 ~ +125 °C
INSULATION RESISTANCE	IR	500MΩ min./ DC 100V
SHUNT CAPACITANCE	C ₀	2.0 typical pF
MOTIONAL CAPACITANCE	C ₁	0.003 pF typical
AGING (FIRST YEAR)	Δf/f ₀	±3 PPM max. @ +25°C

PACKAGE DIMENSIONS (mm)

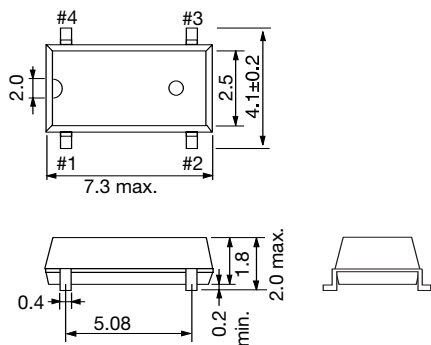

Figure 1) ECX-3TA – Top, Side and End views

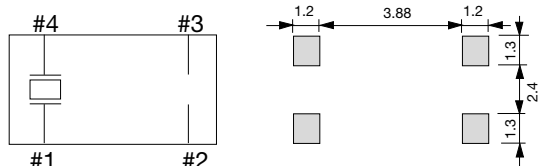
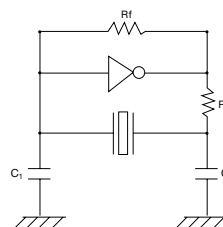

Figure 2) ECX-3TA – Land Pattern - Top view

RECOMMENDED OSCILLATION CIRCUIT



ELECTRICAL CHARACTERISTICS

IC: TC 4069P
 R_f: 10MΩ
 R_d: 330KΩ (As required)
 C₁ = 22pF, C₂ = 22pF
 V_{DD} = 3.0V

In this circuit, low drive level with a maximum of 1μW is recommended. If excessive drive is applied, irregular oscillation or quartz element fractures may occur.

PARABOLIC TEMPERATURE CURVE

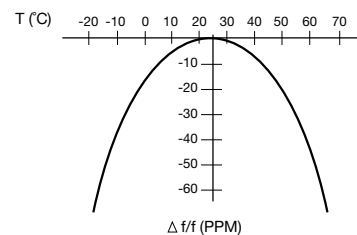

To determine frequency stability, use parabolic curvature. For example: What is the stability at 45°C?

- 1) Change in T (°C) = 45 - 25 = 20°C
- 2) Change in frequency = -0.04 PPM x (ΔT)²
 = -0.04 PPM x (20)²
 = -16.0 PPM

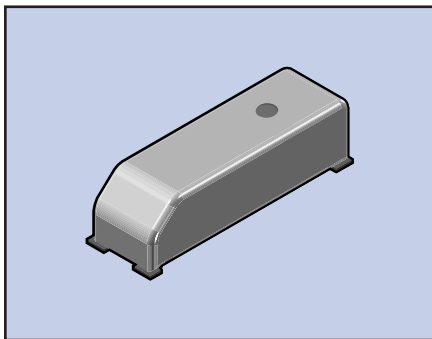

The miniature ECX-26 and the sub-miniature ECX-15 are compact, cost effective SMD tuning fork crystals. The slimline molded package requires less space than other SMD tuning fork crystals.

FEATURES

- Cost effective
- Low profile
- Long term stability
- Tape & Reel packaging

PART NUMBERING GUIDE "EXAMPLE"

MANUFACTURER	FREQUENCY (32.768 MHz)	LOAD CAPACITANCE*	PACKAGE TYPE
ECS	- .327	- 12.5	- 26

* Package type examples (26=ECX-26, 27=ECX-15) Sample Part Number: ECS-.327-12.5-26

OPERATING CONDITIONS/ELECTRICAL CHARACTERISTICS

PARAMETERS	CONDITIONS	ECX-26			ECX-15			UNITS
		MIN	TYP	MAX	MIN	TYP	MAX	
FREQUENCY RANGE	F ₀		32.768			32.768		KHz
FREQUENCY TOLERANCE	Δf/f ₀			±20			±20	PPM
LOAD CAPACITANCE	Optional CL available		12.5			12.5		pF
DRIVE LEVEL	DL			1.0			1.0	μW
EQUIV. SERIES RESISTANCE	R ₁			50K			55K	Ω
Q-FACTOR	Q		70K			70K		Q
TURNOVER TEMPERATURE		+20	+25	+30	+20	+25	+30	°C
TEMPERATURE COEFFICIENT	β		-0.35	-0.04		-0.35	-0.04	PM/°C
SHUNT CAPACITANCE	C ₀		0.9			0.95		pF
CAPACITANCE RATIO			360			380		
OPERATING TEMP RANGE	T _{OPR}	-20		+70	-20		+70	°C
STORAGE TEMP RANGE	T _{STG}	-40		+125	-40		+125	°C
INSULATION RESISTANCE	@ 100V DC ±15V	500M			500M			Ω
AGING (FIRST YEAR)	@ +25°C ±3°C			±3			±3	PPM
MOTION CAPACITANCE	C ₁		0.0025			+0.0025		PF

PACKAGE DIMENSIONS (mm)

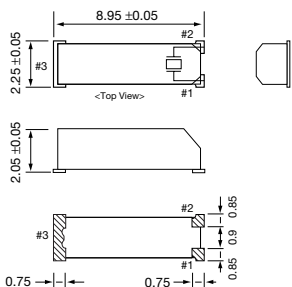

Figure 1) ECX-26 Top, Side Bottom & End views

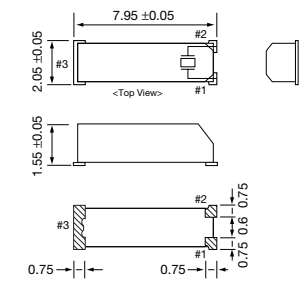

Figure 3) ECX-15 Top, Side Bottom & End views

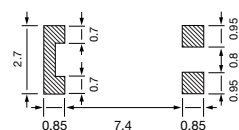

Figure 2) ECX-26 Land Pattern

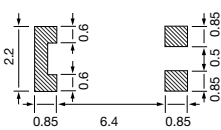
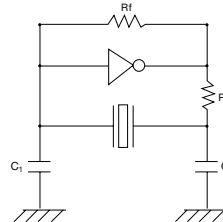

Figure 4) ECX-15 Land Pattern

RECOMMENDED OSCILLATION CIRCUIT



ELECTRICAL CHARACTERISTICS

IC: TC 4069P

R_f: 10MΩ

R_d: 330KΩ (As required)

C₁ = 22pF, C₂ = 22pF

V_{DD} = 3.0V

In this circuit, low drive level with a maximum of 1μW is recommended. If excessive drive is applied, irregular oscillation or quartz element fractures may occur.

PARABOLIC TEMPERATURE CURVE

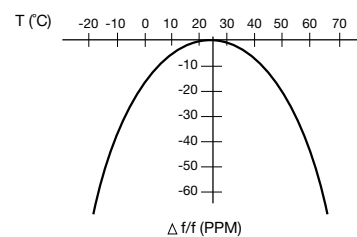

To determine frequency stability, use parabolic curvature. For example: What is the stability at 45°C?

- 1) Change in T (°C) = 45 - 25 = 20°C
- 2) Change in frequency = -0.04 PPM x (ΔT)²
= -0.04 PPM x (20)²
= -16.0 PPM

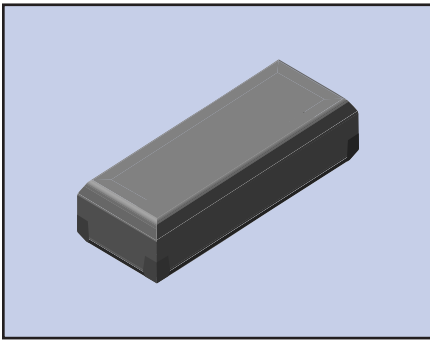

The ultra-miniature ECX-31 is a very compact SMD Tuning Fork Crystal. The 3.2 x 1.2 x 1 mm package is ideal for applications where real estate is at a premium.

FEATURES

- Low profile
- long term stability
- 1mm height max.
- Tape and Reel (3,000 pcs)

PART NUMBERING GUIDE "EXAMPLE"

MANUFACTURER	FREQUENCY (32.768 MHz)	LOAD CAPACITANCE	PACKAGE TYPE
ECS	- .327	- 12.5	- 32

Part Number: ECS-.327-12.5-32

OPERATING CONDITIONS/ELECTRICAL CHARACTERISTICS

PARAMETERS	CONDITIONS	MINIMUM	TYPICAL	MAXIMUM	UNITS
FREQUENCY	F _o		32.768		KHz
FREQUENCY TOLERANCE	Δf/f _o			±20	PPM
LOAD CAPACITANCE			12.5		pF
DRIVE LEVEL	D _L			1.0	μW
EQUIVALENT SERIES RESISTANCE	R _L			50K	Ω
TURNOVER TEMPERATURE		+20	+25	+30	°C
TEMPERATURE COEFFICIENT	β		-0.035	-0.043	ppm/°C ²
SHUNT CAPACITANCE	C ₀		1.7		pF
OPERATING TEMPERATURE RANGE	T _{OPR}	-40		+85	°C
STORAGE TEMPERATURE RANGE	T _{STG}	-55		+125	°C
INSULATION RESISTANCE	@ 100v DC ±15v	500M			Ω

PACKAGE DIMENSIONS (mm)

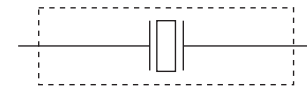
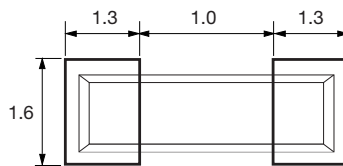
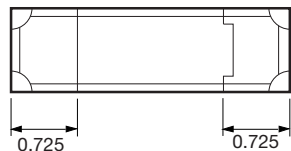
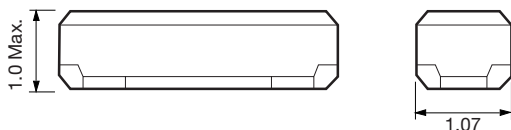
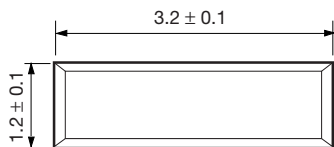

Figure 1) ECX-32 - Top, Side Bottom & End views

Figure 2) ECX-32 Land Pattern

Figure 3) ECX-32 Crystal Connection



This wide frequency range SMD quartz crystal is an excellent choice for surface mount applications. The ruggedized molded package is made from the same thermoplastic that is industry standard for integrated circuits.

FEATURES

- Low profile
- Industry standard footprint
- High temperature seal capabilities
- Excellent shock resistance
- Excellent environmental characteristics
- Tape and Reel (1000 pcs)

PART NUMBERING GUIDE "EXAMPLE"

	FREQUENCY (16.0000 MHz)	LOAD CAPACITANCE*	PACKAGE TYPE
ECS	160	20	7S

* Load capacitance (xx=xx pF, S= series resonance)
 Note: See Product Selection Guide for additional options.

OPERATING CONDITIONS/ELECTRICAL CHARACTERISTICS

PARAMETERS	CONDITIONS	MINIMUM	TYPICAL	MAXIMUM	UNITS
FREQUENCY RANGE	f_0	3.57		70.00	MHz
SHUNT CAPACITANCE	C_0			7.0	pF
LOAD CAPACITANCE	C_L (Customer Specified)	12	20.0 standard	Series	pF
DRIVE LEVEL	3.50 ~ 70.00MHz			100	μ W
CALIBRATION TOLERANCE	@ 25°C	-30		+30	PPM
FREQUENCY STABILITY	$\Delta f/f_0$	-50		+50	PPM
OPERATING TEMPERATURE RANGE	T_{OPR}	-10		+70	°C
STORAGE TEMPERATURE RANGE	T_{STG}	-40		+85	°C

EQUIVALENT SERIES RESISTANCE / MODE OF OSCILLATION

FREQUENCY RANGE (MHz)	MODE	MAX ESR Ω	FREQUENCY RANGE (MHz)	MODE	MAX ESR Ω
3.570 ~ 3.999	Fundamental	250	9.000 ~ 12.999	Fundamental	60
4.000 ~ 4.999	Fundamental	150	13.000 ~ 19.999	Fundamental	40
5.000 ~ 5.999	Fundamental	120	20.000 ~ 30.000	Fundamental	30
6.000 ~ 6.999	Fundamental	100	30.000 ~ 70.000	3rd O/T	100
7.000 ~ 8.999	Fundamental	80			

PACKAGE DIMENSIONS (mm)

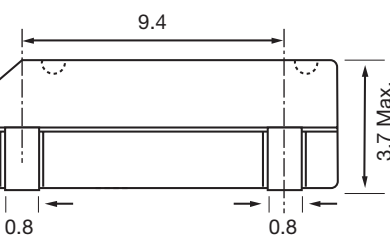

Figure 1) ECX-3S - Top, Side and End views

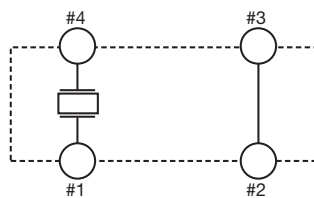

Figure 2) Internal Connections - Top view

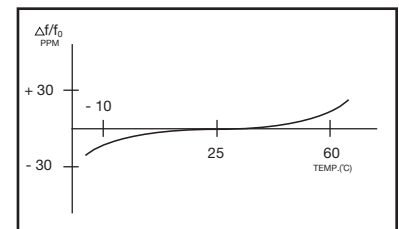

Figure 3) Frequency vs Temperature Curve

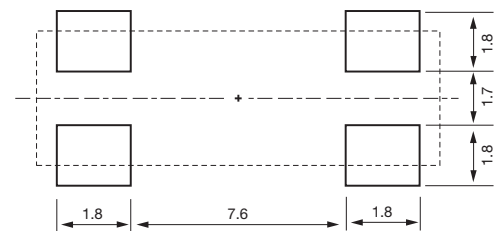
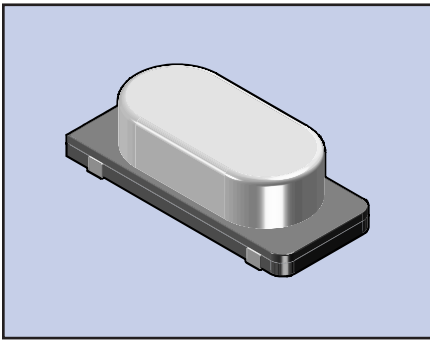

Figure 4) ECX-3S Land Pattern - Bottom view



The CSM-4A is a SMD version of the HC-49US leaded crystal. The CSM-4A has a case height of 5 mm maximum in a resistance-weld metal package. The CSM-4A is also pin out compatible with the EPSON MA-506.

FEATURES

- Cost effective
- Resistance-weld sealing
- Extended Temp range available
- Tape & Reel (1,000 pcs)

PART NUMBERING GUIDE "EXAMPLE"

MANUFACTURER	FREQUENCY (4.000 MHz)	LOAD CAPACITANCE*	PACKAGE TYPE
ECS	40	20	28A

* Load capacitance (xx=xx pF, S=series resonance) Package Type examples (-28A = 5.0 mm max. height, -28AL = 4.0 mm max. height)
 Note: See Product Selection Guide for additional options including tighter tolerances or extended temperature range.

OPERATING CONDITIONS/ELECTRICAL CHARACTERISTICS

PARAMETERS	CONDITIONS	MINIMUM	TYPICAL	MAXIMUM	UNITS
FREQUENCY RANGE		3.579545		70.000	MHz
CALIBRATION TOLERANCE	@ +25°C			±30*	PPM
FREQUENCY STABILITY ref @25°C	-10 ~ +70°C			±50*	PPM
SHUNT CAPACITANCE				7	pF
LOAD CAPACITANCE	C _L (Customer Specified)	10	20.0 standard	Series	pF
DRIVE LEVEL	DL			500	µW
OPERATING TEMPERATURE	T _{OPR} **	-10		+70	°C
STORAGE TEMPERATURE	T _{STG}	-30		+85	°C
AGING CHARACTERISTICS (Per Year)	@ +25°C ± 3°C per year			±5	PPM

* Tighter specifications are available. **Extended temperature range available.

EQUIVALENT SERIES RESISTANCE / MODE OF OSCILLATION

FREQUENCY RANGE (MHz)	MODE OF OSC	MAX ESR Ω	FREQUENCY RANGE (MHz)	MODE OF OSC	MAX ESR Ω
3.579545 ~ 4.999	Fundamental	200	9.000 ~ 12.000	Fundamental	60
5.000 ~ 5.999	Fundamental	150	13.000 ~ 19.999	Fundamental	40
6.000 ~ 6.999	Fundamental	100	20.000 ~ 30.000	Fundamental	30
7.000 ~ 8.999	Fundamental	80	27.000 ~ 80.000	3rd O/T	100

PACKAGE DIMENSIONS (mm)

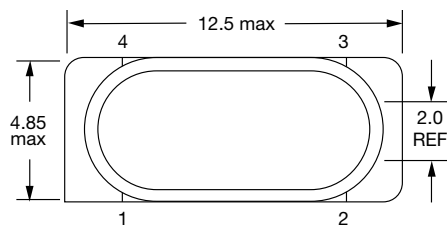

Height "H" (max.)	
-28A	5.0 mm
-28AL	4.0 mm

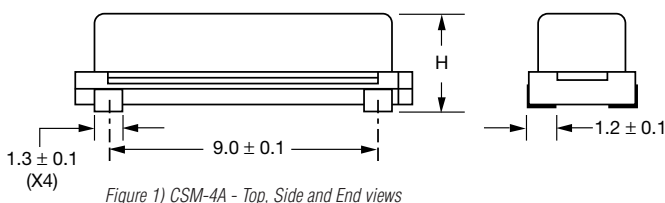
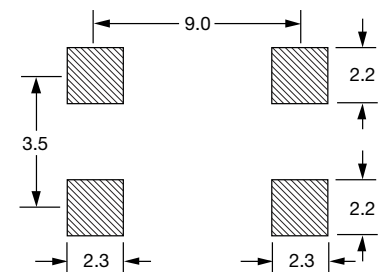
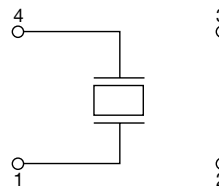
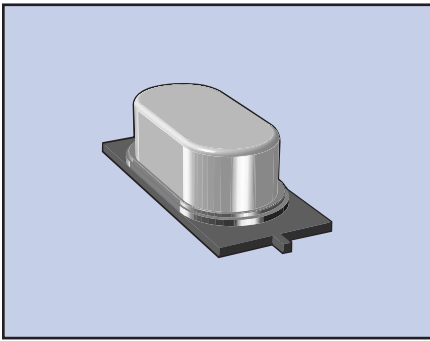

Figure 2) CSM-4A Internal Connections

Figure 3) Land Pattern



The CSM-7 is an excellent choice for the SMD version of the HC-49US leaded crystal. The CSM-7 has a case height of 4.3 mm maximum in a resistance weld metal package. A package profile of 3.2 mm maximum is also available.

FEATURES

- Cost effective
- Space saving design
- Low profile
- Tape & Reel (1,000 pcs)

PART NUMBERING GUIDE "EXAMPLE"

ECS	FREQUENCY (16.0000 MHz)	LOAD CAPACITANCE*	PACKAGE TYPE**
-	160	20	5P

* Load capacitance (xx=xx pF, S= series resonance), ** Package Type examples (-5P= 4.3mm max. height, -5PL= 3.2mm max. height)
 For extended temp range of -40 to +85°C ad -DN suffix for example ECS-160-20-5P-DN
 Note: See Product Selection Guide for additional options.

OPERATING CONDITIONS/ELECTRICAL CHARACTERISTICS

PARAMETERS	CONDITIONS	MINIMUM	TYPICAL	MAXIMUM	UNITS
FREQUENCY RANGE	f_0	3.57		70.000	MHz
FREQUENCY TOLERANCE	@ +25°C			±30	PPM
FREQUENCY STABILITY, ref @ 25°C	Standard -10 +70°C			±50	PPM
	"DN" Option -40 +85°C			±100	PPM
OPERATING TEMPERATURE	Standard	-10		+70	°C
	"DN" Option	-40		+85	°C
STORAGE TEMPERATURE (T _{STG})	T _{STG}	-40		+105	°C
SHUNT CAPACITANCE (C ₀)	C ₀			7.0	pF
LOAD CAPACITANCE (C _L)	C _L (Customer Specified)	10	20.0 standard	Series	pF
DRIVE LEVEL	3.570 - 70.000 MHz			0.5	mW
AGING (FIRST YEAR)	@ +25°C			±5.0	PPM

EQUIVALENT SERIES RESISTANCE

FREQUENCY RANGE (MHz)	MODE	MAX ESR Ω	FREQUENCY RANGE (MHz)	MODE	MAX ESR Ω
3.570 ~ 4.999	Fundamental	150	13.000 ~ 19.000	Fundamental	40
5.000 ~ 5.999	Fundamental	80	20.000 ~ 29.000	Fundamental	30
6.000 ~ 6.999	Fundamental	70	26.000 ~ 39.999	3rd O/T	100
7.000 ~ 8.999	Fundamental	60	40.000 ~ 70.000	3rd O/T	80
9.000 ~ 12.999	Fundamental	50			

PACKAGE DIMENSIONS (mm)

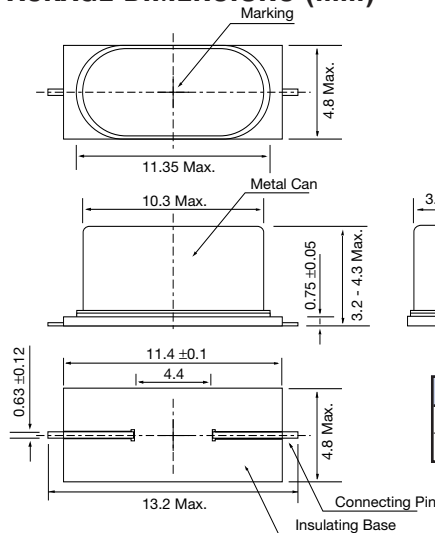

Figure 1) CSM-7 - Top, Side, Bottom and End views

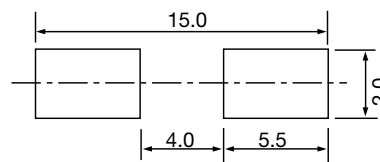

Figure 2) CSM-7 Land Pattern - Bottom view

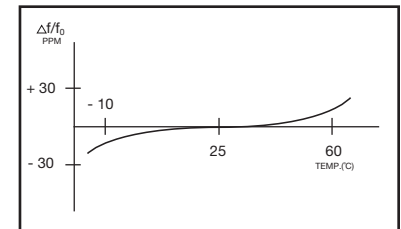
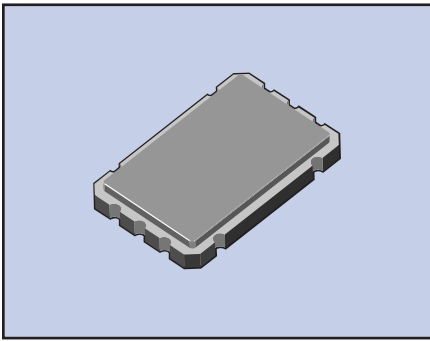

Figure 3) Frequency vs Temperature Curve

Height "H" (max.)	
-5P	4.3 mm
-5PL	3.2 mm



The CSM-8 Series is a very cost effective, low profile SMD quartz crystal. The glass sealed ceramic package is available in three optional land pad configurations. It is ideal for PCMCIA, ethernet and fax modem card applications.

FEATURES

- Glass sealed ceramic package
- Tight stability / high reliability
- Wide frequency range
- High frequency fundamental available
- Two optional footprints
- Tape & Reel (1,000 pcs)

PART NUMBERING GUIDE "EXAMPLE"

ECS	FREQUENCY (16.000MHz)	LOAD CAPACITANCE*	PACKAGE TYPE**
-	160	- 20	- 20A

* Load capacitance (xx=xx pF, S= series resonance), ** Package Type examples (20A = CSM-8A, 20B = CSM-8B)
 Note: See Product Selection Guide for additional options.

OPERATING CONDITIONS/ELECTRICAL CHARACTERISTICS

PARAMETERS	CONDITIONS	MINIMUM	TYPICAL	MAXIMUM	UNITS
FREQUENCY RANGE	f_0	9.8		100.0	MHz
CALIBRATION TOLERANCE	@ +25°C	-30		+30	PPM
FREQUENCY STABILITY, ref @ 25°C	-10 ~ +70°C	-50		+50	PPM
SHUNT CAPACITANCE	C_0			5.0	pF
LOAD CAPACITANCE (C_L)	(Customer Specified)	10.0	20.0 standard	Series	pF
DRIVE LEVEL (D_L)	9.8 ~ 100.0MHz			0.5	mW
OPERATING TEMPERATURE	T_{OPR}	-10		+70	°C
STORAGE TEMPERATURE	T_{STG}	-40		+85	°C
AGING (FIRST YEAR)	@ +25°C	-5.0		+5.0	PPM

EQUIVALENT SERIES RESISTANCE / MODE OF OSCILLATION

FREQUENCY RANGE (MHz)	MODE	MAX ESR Ω	FREQUENCY RANGE (MHz)	MODE	MAX ESR Ω
9.800 ~ 15.999	Fundamental	60	28.000 ~ 34.999	3rd O/T	80
16.000 ~ 42.000	Fundamental	40	35.000 ~ 100.000	3rd O/T	60

PACKAGE DIMENSIONS (mm)

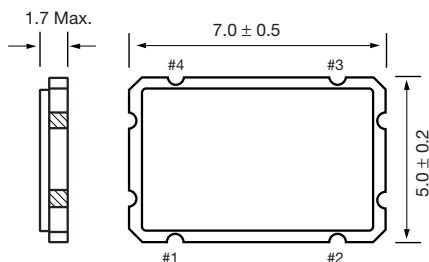

Figure 1) CSM-8 – Side and Top view

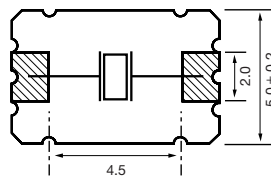

Figure 2) CSM-8A – Pad Configuration Bottom view

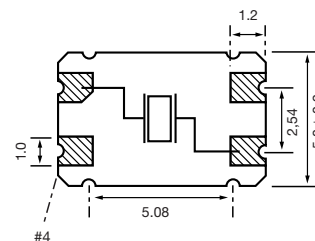

Figure 3) CSM-8B – Pad Configuration Bottom view

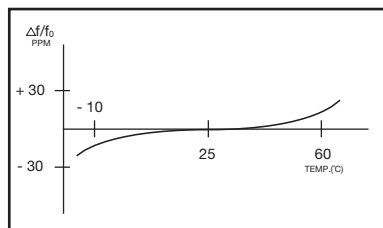

Figure 4) Frequency vs Temperature Curve

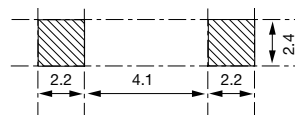

Figure 5) CSM-8A – Recommended Solder Pad Layout Top view

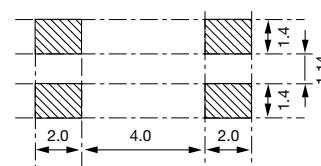
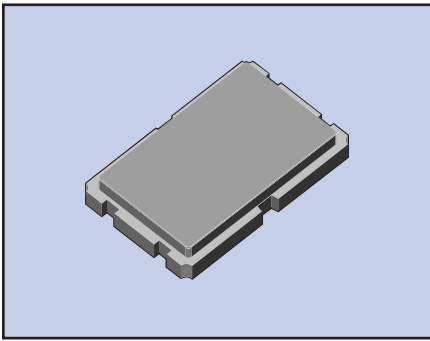

Figure 6) CSM-8B – Recommended Solder Pad Layout Top view



The CSM-8M is a 1.3mm max. low profile SMD quartz crystal. This seam welded metal lid/ceramic package crystal is ideal for PCMCIA ethernet and fax modem card applications.

FEATURES

- Seam welded metal lid / ceramic package
- 1.3mm max. low profile
- Tight stability / high reliability
- Wide frequency range
- Tape & Reel (1,000 pcs)

PART NUMBERING GUIDE "EXAMPLE"

	FREQUENCY (16.000MHz)	LOAD CAPACITANCE*	PACKAGE TYPE
ECS	- 160 -	20	20BM

* Load capacitance (xx=xx pF, S= series resonance)
 Note: See Product Selection Guide for additional options.

OPERATING CONDITIONS/ELECTRICAL CHARACTERISTICS

PARAMETERS	CONDITIONS	MINIMUM	TYPICAL	MAXIMUM	UNITS
FREQUENCY RANGE		8.0		125.0	MHz
CALIBRATION TOLERANCE	@ +25°C	-30		+30	PPM
FREQUENCY STABILITY, ref @ 25°C	-10 ~ +70°C	-50		+50	PPM
SHUNT CAPACITANCE	C ₀			5.0	pF
LOAD CAPACITANCE (C _L)	(Customer Specified)	10.0	20.0 standard	Series	pF
DRIVE LEVEL (D _L)	8.0 ~ 100.0MHz			0.5	mW
OPERATING TEMPERATURE	T _{OPR}	-10		+70	°C
STORAGE TEMPERATURE	T _{STG}	-40		+85	°C
AGING (FIRST YEAR)	@ +25°C	-5.0		+5.0	PPM

EQUIVALENT SERIES RESISTANCE / MODE OF OSCILLATION

FREQUENCY RANGE (MHz)	MODE	MAX ESR Ω	FREQUENCY RANGE (MHz)	MODE	MAX ESR Ω
8.000 ~ 15.999	Fundamental	60	28.000 ~ 100.000	3rd O/T	60
16.000 ~ 42.000	Fundamental	40	84.000 ~ 125.000	5th O/T	80

PACKAGE DIMENSIONS (mm)

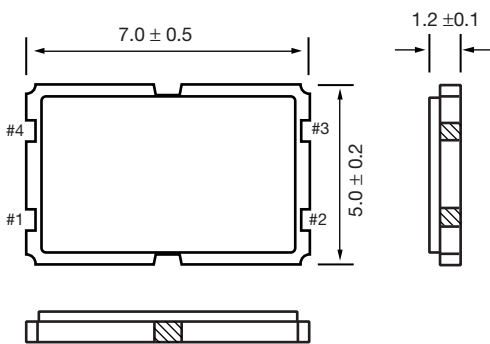

Figure 1) CSM-8M – Top and Side views

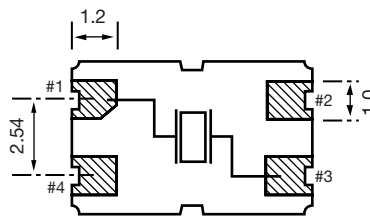

Figure 2) CSM-8M – Pad Configuration Bottom view

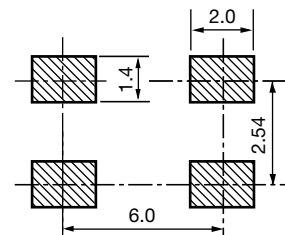

Figure 3) CSM-8M – Recommended Solder Pad Layout, Top view

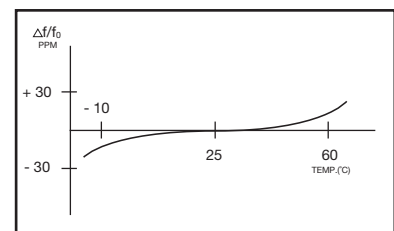
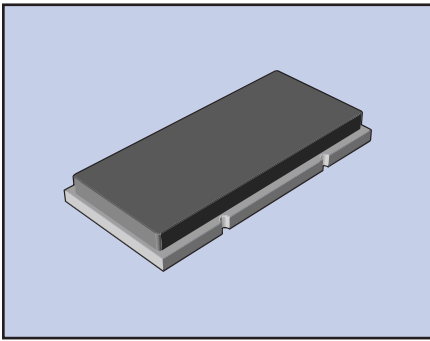

Figure 4) Frequency vs Temperature Curve



The CSM-12 is enclosed in a ceramic package. It is an excellent choice for a low profile crystal with a height of 2.5 mm.

FEATURES

- Cost effective
- Space saving design
- Low profile
- Tape & Reel (1,000 pcs)

PART NUMBERING GUIDE "EXAMPLE"

ECS	FREQUENCY (16.0000MHz)	LOAD CAPACITANCE*	PACKAGE TYPE
-	160	- 20	- 18

* Load capacitance (xx=xx pF, S= series resonance)
 Note: See Product Selection Guide for additional options.

OPERATING CONDITIONS/ELECTRICAL CHARACTERISTICS

PARAMETERS	CONDITIONS	MINIMUM	TYPICAL	MAXIMUM	UNITS
FREQUENCY RANGE	f_0	3.57		30.00	MHz
MODE OF OSCILLATION	Fundamental				
LOAD CAPACITANCE	C_L	10.0	20.0 standard	Series	pF
DRIVE LEVEL	D_L			100	μ W
FREQUENCY TOLERANCE	@ +25°C	-30		+30	PPM
EQUIVALENT SERIES RESISTANCE	R_1		See ESR CHART		Ohms
FREQUENCY STABILITY	$\Delta f/f_0$	-50		+50	PPM
OPERATING TEMP. RANGE	T_{OPR}	-10		+70	°C
STORAGE TEMP. RANGE	T_{STG}	-40		+85	°C
SHUNT CAPACITANCE	C_0			7.0	pF
AGING (FIRST YEAR @ +25°C)	$\Delta f/f_0$	-5.0		+5.0	PPM

PACKAGE DIMENSIONS (mm)

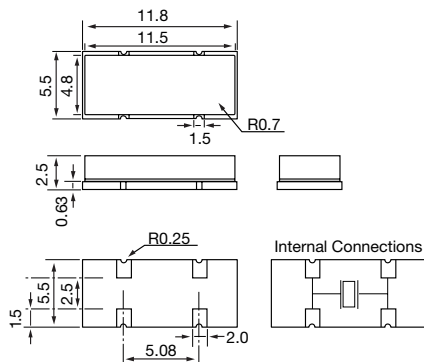

Figure 1) CSM-12 - Top, Side and Bottom views

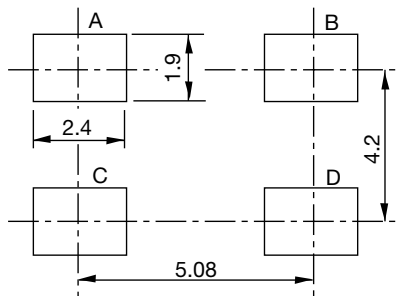

Figure 2) CSM-12 Land Pattern - Bottom view

EQUIVALENT SERIES RESISTANCE CURVE	
FREQUENCY MHz	(Ω MAX.)
3.57 ~ 3.999	200
4.00 ~ 5.999	150
6.00 ~ 9.999	100
10.00 ~ 13.999	80
14.00 ~ 30.00	50

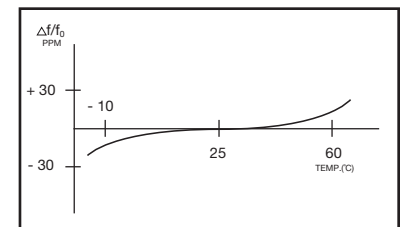
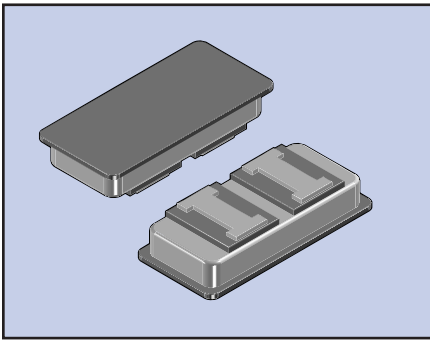

Figure 3) Frequency vs Temperature Curve



The ECX-19A SMD crystal is pin out compatible with our CSM-12. The ECX-19A covers a wide frequency range and has a 2.0 mm height profile.

FEATURES

- Compact and low profile
- Resistance-weld sealed
- Extended Temp range available
- Tape & Reel (1,000 pcs.)

PART NUMBERING GUIDE "EXAMPLE"

MANUFACTURER	FREQUENCY (4.000 MHz)	LOAD CAPACITANCE*	PACKAGE TYPE
ECS	40	20	19A

* Load capacitance (xx=xx pF, S=series resonance)

Note: See Product Selection Guide for additional options including tighter tolerances or extended temperature range.

OPERATING CONDITIONS/ELECTRICAL CHARACTERISTICS

PARAMETERS	CONDITIONS	MINIMUM	TYPICAL	MAXIMUM	UNITS
FREQUENCY RANGE		3.579545		80.000	MHz
CALIBRATION TOLERANCE	@ +25°C			±30*	PPM
FREQUENCY STABILITY ref @25°C	-10 ~ +70°C			±50*	PPM
SHUNT CAPACITANCE				7	pF
LOAD CAPACITANCE	C _L (Customer Specified)	10	20.0 standard	Series	pF
DRIVE LEVEL	DL			100	μW
OPERATING TEMPERATURE	T _{OPR} **	-10		+70	°C
STORAGE TEMPERATURE	T _{STG}	-30		+85	°C
AGING CHARACTERISTICS (Per Year)	@ +25°C ± 3°C per year			±5	PPM

* Tighter specifications are available. **Extended temperature range available.

EQUIVALENT SERIES RESISTANCE / MODE OF OSCILLATION

FREQUENCY RANGE (MHz)	MODE OF OSC	MAX ESR Ω	FREQUENCY RANGE (MHz)	MODE OF OSC	MAX ESR Ω
3.579545 ~ 3.999	Fundamental	200	10.000 ~ 13.999	Fundamental	80
4.000 ~ 5.999	Fundamental	150	14.000 ~ 30.000	Fundamental	50
6.000 ~ 9.999	Fundamental	100	27.000 ~ 80.000	3rd O/T	80

PACKAGE DIMENSIONS (mm)

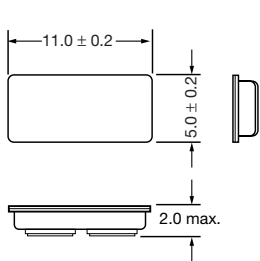

Figure 1) ECX-19A - Top, Side, Bottom and End views

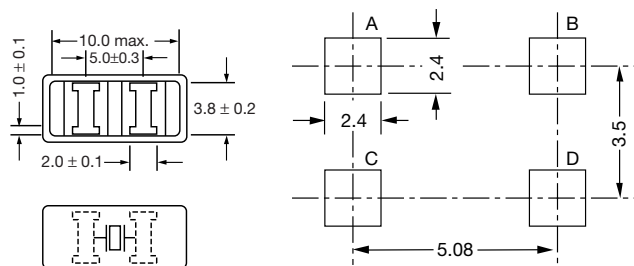

Figure 2) ECX-19A Land Pattern

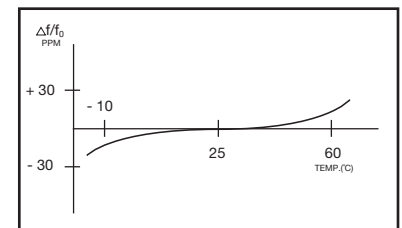
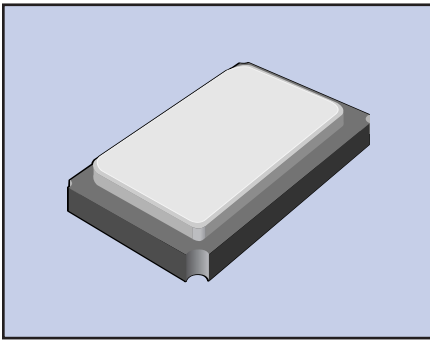

Figure 3) Frequency vs Temperature Curve



The ECX-64 delivers unmatched frequency stability with a frequency range from 12MHz to 100MHz with an operating temperature of -10° to +70°C. Aging characteristics are exceptional utilizing advanced cold-sealing processes with a ceramic housing / metal cover. These specifications along with a dimensional height of only 1.1mm make this SMD crystal the perfect choice for compact wireless communication applications.

FEATURES

- 1.1 mm height
- Wide frequency range availability
- Excellent aging characteristics
- High frequency fundamental capability
- Ultra miniature design
- Tape & Reel (1,000 pcs)

PART NUMBERING GUIDE "EXAMPLE"

	FREQUENCY (16.0000 MHz)	LOAD CAPACITANCE*	PACKAGE TYPE
ECS	- 160 -	20	23B

* Load capacitance (xx=xx pF, S= series resonance)
 Note: See Product Selection Guide for additional options.

OPERATING CONDITIONS/ELECTRICAL CHARACTERISTICS

PARAMETERS	CONDITIONS	MINIMUM	TYPICAL	MAXIMUM	UNITS
FREQUENCY RANGE		12.0		100.0	MHz
CALIBRATION TOLERANCE	@ +25°C	-30		+30	PPM
FREQUENCY STABILITY ref. 25°C	-10~ +70°C	-50	See Table 1	+50	PPM
SHUNT CAPACITANCE	C ₀			7.0	pF
LOAD CAPACITANCE	C _L (Customer Specified)	10.0	20.0 standard	Series	pF
DRIVE LEVEL	D _L			0.1	mW
OPERATING TEMPERATURE	T _{OPR}	-10		+70	°C
STORAGE TEMPERATURE	T _{STG}	-40		+85	°C
AGING CHARACTERISTICS (FIRST YEAR)	@ +25°C	-2.0		+2.0	PPM

EQUIVALENT SERIES RESISTANCE / MODE OF OSCILLATION

FREQUENCY RANGE (MHz)	MODE OF OSC.	MAX. ESR (Ω)	FREQUENCY RANGE (MHz)	MODE OF OSC	MAX ESR (Ω)
12.000 ~ 15.999	Fundamental	80	20.000 ~ 49.999	Fundamental	40
16.000 ~ 19.999	Fundamental	60	27.000 ~ 100.000	3rd OT	100

PACKAGE DIMENSIONS (mm)

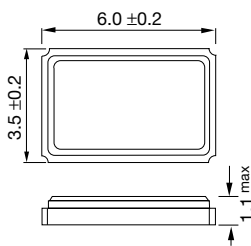

Figure 1) ECX-64 - Top and Side views

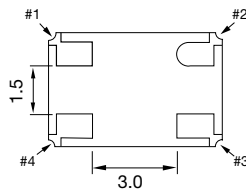

Figure 2) Land Pattern - Bottom view

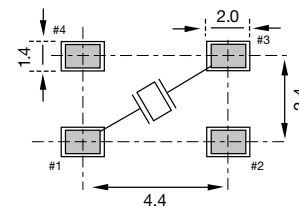

Figure 3) Recommended Solder Pad Layout - Top view

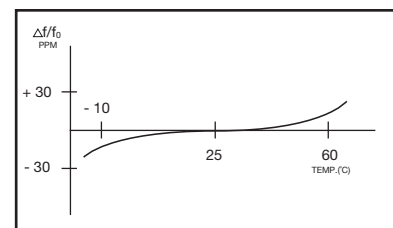
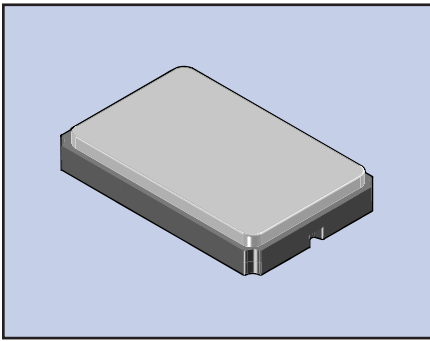

Figure 4) Frequency vs Temperature Curve



The ECX-64A and ECX-64C are subminiature SMD crystals with 3.5 X 6 mm footprint. This cost effective all ceramic package is available in 2 and 4 pad versions. The package height measures 1.1 mm max. which is ideal for densely populated PCB applications.

FEATURES

- Compact and low profile
- Glass sealed ceramic package
- Tape & Reel (1,000 pcs)

PART NUMBERING GUIDE *"EXAMPLE"*

MANUFACTURER	FREQUENCY (16.0000 MHz)	LOAD CAPACITANCE*	PACKAGE TYPE**
ECS	160	20	23A

* Load capacitance (xx=xx pF, S=series resonance). **Package Type Examples (23A=ECX-64A, 23C=ECX-64C)
 Note: See Product Selection Guide for additional options including tighter tolerances or extended temperature range.

OPERATING CONDITIONS/ELECTRICAL CHARACTERISTICS

PARAMETERS	CONDITIONS	MINIMUM	TYPICAL	MAXIMUM	UNITS
FREQUENCY RANGE		12.600		100.000	MHz
CALIBRATION TOLERANCE	@ +25°C			±30*	PPM
FREQUENCY STABILITY ref @25°C	-10 ~ +70°C			±50*	PPM
SHUNT CAPACITANCE				7	pF
LOAD CAPACITANCE	C _L (Customer Specified)	10	16.0 standard	Series	pF
DRIVE LEVEL	DL			100	µW
OPERATING TEMPERATURE	T _{OPR} **	-10		+70	°C
STORAGE TEMPERATURE	T _{STG}	-40		+85	°C
AGING CHARACTERISTICS (Per Year)	@ +25°C ± 3°C per year			±5	PPM

* Tighter specifications are available. **Extended temperature range available.

EQUIVALENT SERIES RESISTANCE / MODE OF OSCILLATION

FREQUENCY RANGE (MHz)	MODE OF OSC	MAX ESR Ω	FREQUENCY RANGE (MHz)	MODE OF OSC	MAX ESR Ω
12.600 ~ 15.999	Fundamental	80	20.000 ~ 49.999	Fundamental	40
16.000 ~ 19.999	Fundamental	60	50.000 ~ 100.000	3rd O/T	100

PACKAGE DIMENSIONS (mm)

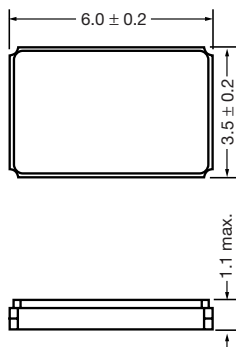

Figure 1) ECX-64A & 64C - Top and side views

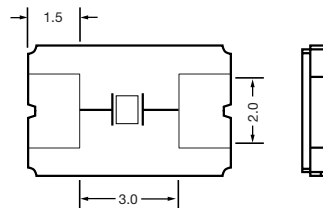

Figure 2) ECX-64A - Pad Configuration Bottom and End views

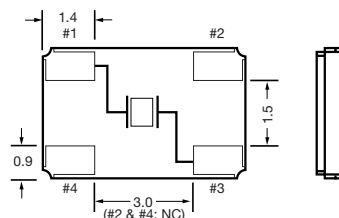

Figure 3) ECX-64C - Pad Configuration Bottom and End views

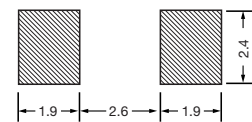

Figure 4) ECX-64A - Recommended Solder Pad Layout

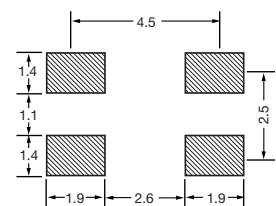
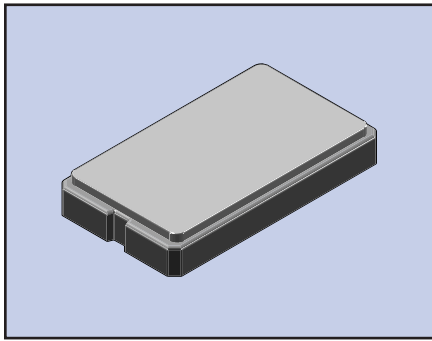

Figure 5) ECX-64C - Recommended Solder Pad Layout



The ECX-53 is our sub miniature SMD crystal with a 3.2 x 5 mm footprint. This package is ideal for todays compact wireless applications where board space is critical.

FEATURES

- Compact and low profile
- Glass sealed ceramic package
- Tape & Reel (1000 pcs)

PART NUMBERING GUIDE "EXAMPLE"

	FREQUENCY (16.000 MHz)	LOAD CAPACITANCE*	PACKAGE TYPE**
ECS	160	20	30

* Load capacitance (xx=xx pF, S=series resonance) ** Package Type examples (30=ECX-53)
 Note: See Product Selection Guide for additional options including tighter tolerances or extended temperature range.

OPERATING CONDITIONS/ELECTRICAL CHARACTERISTICS

PARAMETERS	CONDITIONS	MINIMUM	TYPICAL	MAXIMUM	UNITS
FREQUENCY RANGE		12.000		40.000	MHz
CALIBRATION TOLERANCE	@ +25°C			±50*	PPM
FREQUENCY STABILITY ref @25°C	-10 ~ +60°C			±50*	PPM
SHUNT CAPACITANCE				5	pF
LOAD CAPACITANCE	C _L (Customer Specified)	12	16 standard	Series	pF
DRIVE LEVEL	DL			100	µW
OPERATING TEMPERATURE	T _{OPR} **	-10		+60	°C
STORAGE TEMPERATURE	T _{STG}	-40		+85	°C
AGING CHARACTERISTICS (Per Year)	@ +25°C ± 3°C per year			±5	PPM

* Tighter specifications are available. **Extended temperature range available.

EQUIVALENT SERIES RESISTANCE / MODE OF OSCILLATION

FREQUENCY RANGE (MHz)	MODE OF OSC	MAX ESR Ω	FREQUENCY RANGE (MHz)	MODE OF OSC	MAX ESR Ω
14.300 ~ 17.999	Fundamental	100	25.000 ~ 40.000	Fundamental	60
18.000 ~ 24.999	Fundamental	80			

PACKAGE DIMENSIONS (mm)

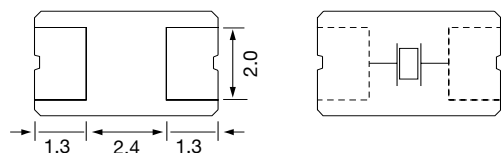
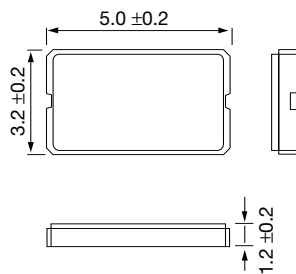

Figure 1) ECX-53 - Top, Side Bottom and End views

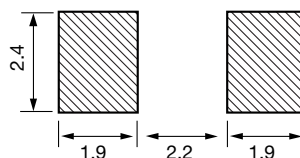

Figure 2) Land Pattern

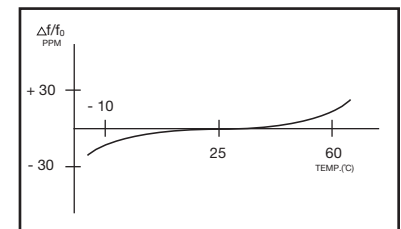
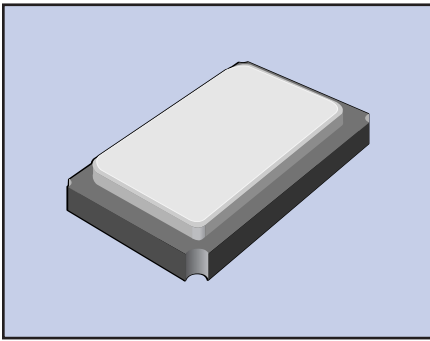

Figure 3) Frequency vs Temperature Curve



The ECX-53B SMD is our sub-miniature SMD crystal with 3.2 x 5 mm footprint. This package is ideal for today's compact wireless applications where board space is critical.

FEATURES

- Compact and low profile
- Seam-welded package
- Tape & Reel (1,000 pcs.)
- High frequency fundamental

PART NUMBERING GUIDE "EXAMPLE"

MANUFACTURER	FREQUENCY (16.000 MHz)	LOAD CAPACITANCE*	PACKAGE TYPE**
ECS	160	20	30B

* Load capacitance (xx=xx pF, S=series resonance) **Package Type Examples (30B=ECX-53B)
 Note: See Product Selection Guide for additional options including tighter tolerances or extended temperature range.

OPERATING CONDITIONS/ELECTRICAL CHARACTERISTICS

PARAMETERS	CONDITIONS	MINIMUM	TYPICAL	MAXIMUM	UNITS
FREQUENCY RANGE		10.000		130.000	MHz
CALIBRATION TOLERANCE	@ +25°C			±50*	PPM
FREQUENCY STABILITY ref @25°C	-20 ~ +70°C			±50*	PPM
SHUNT CAPACITANCE				5	pF
LOAD CAPACITANCE	C _L (Customer Specified)	12	16.0 standard	Series	pF
DRIVE LEVEL	DL			100	µW
OPERATING TEMPERATURE	T _{OPR} **	-20		+70	°C
STORAGE TEMPERATURE	T _{STG}	-40		+85	°C
AGING CHARACTERISTICS (Per Year)	@ +25°C ± 3°C per year			±5	PPM

* Tighter specifications are available. **Extended temperature range available.

EQUIVALENT SERIES RESISTANCE / MODE OF OSCILLATION

FREQUENCY RANGE (MHz)	MODE OF OSC	MAX ESR Ω	FREQUENCY RANGE (MHz)	MODE OF OSC	MAX ESR Ω
10.000 ~ 15.999	Fundamental	80	70.000 ~ 130.000	3rd O/T	100
16.000 ~ 19.999	Fundamental	60	120.000 ~ 130.000	5th O/T	160
20.000 ~ 130.000	Fundamental	50			

PACKAGE DIMENSIONS (mm)

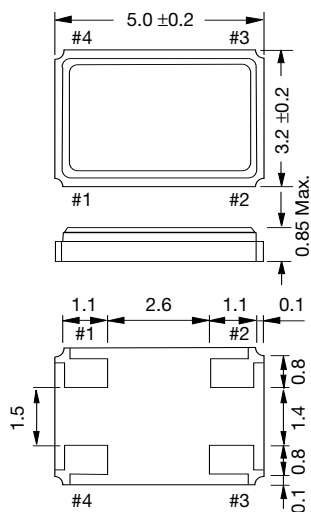

Figure 1) ECX-53B - Top, Side, Bottom and End views

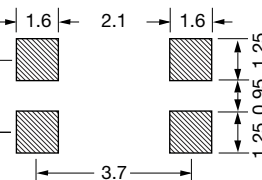
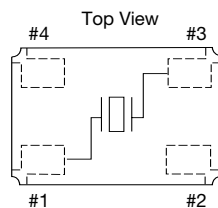
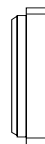

Figure 2) ECX-53B Land Pattern

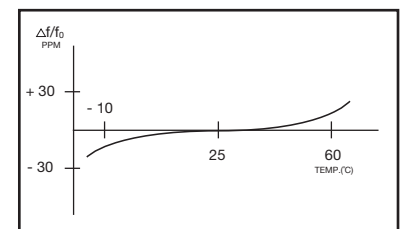
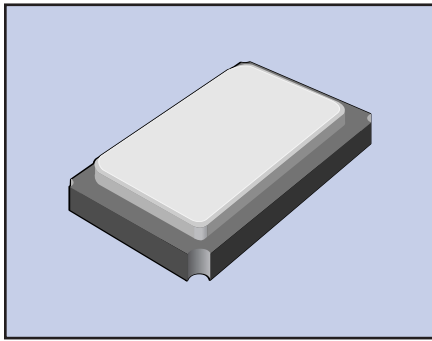

Figure 3) Frequency vs Temperature Curve



The ECX-32 SMD is our smallest sub-miniature SMD crystal with 3.2 x 2.5 mm footprint. This package is ideal for today's compact wireless applications where board space is critical.

FEATURES

- Compact and low profile
- Seam-welded package
- Tape & Reel (1,000 pcs.)

PART NUMBERING GUIDE "EXAMPLE"

MANUFACTURER	FREQUENCY (16.000 MHz)	LOAD CAPACITANCE*	PACKAGE TYPE**
ECS	160	20	33

* Load capacitance (xx=xx pF, S=series resonance) **Package Type Examples (33=ECX-32)
 Note: See Product Selection Guide for additional options including tighter tolerances or extended temperature range.

OPERATING CONDITIONS/ELECTRICAL CHARACTERISTICS

PARAMETERS	CONDITIONS	MINIMUM	TYPICAL	MAXIMUM	UNITS
FREQUENCY RANGE		16.000		60.000	MHz
CALIBRATION TOLERANCE	@ +25°C			±50*	PPM
FREQUENCY STABILITY ref @25°C	-20 ~ +70°C			±50*	PPM
SHUNT CAPACITANCE				5	pF
LOAD CAPACITANCE	C _L (Customer Specified)	12	16.0 standard	Series	pF
DRIVE LEVEL	DL			100	µW
OPERATING TEMPERATURE	T _{OPR} **	-20		+70	°C
STORAGE TEMPERATURE	T _{STG}	-40		+85	°C
AGING CHARACTERISTICS (Per Year)	@ +25°C ± 3°C per year			±5	PPM

* Tighter specifications are available. **Extended temperature range available.

EQUIVALENT SERIES RESISTANCE / MODE OF OSCILLATION

FREQUENCY RANGE (MHz)	MODE OF OSC	MAX ESR Ω	FREQUENCY RANGE (MHz)	MODE OF OSC	MAX ESR Ω
16.000 ~ 29.999	Fundamental	100	30.000 ~ 60.000	Fundamental	50

PACKAGE DIMENSIONS (mm)

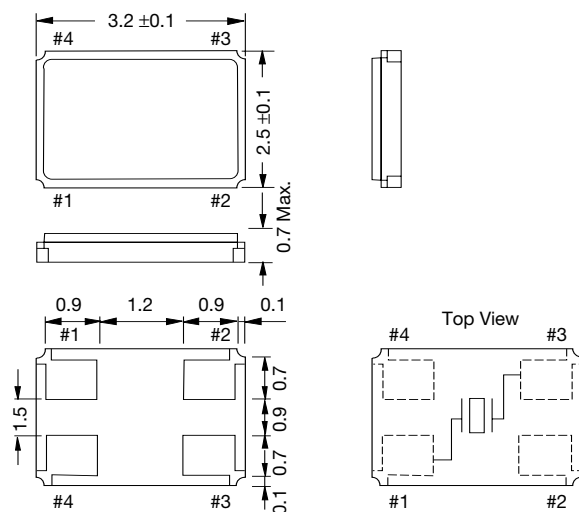

Figure 1) ECX-32 - Top, Side, Bottom and End views

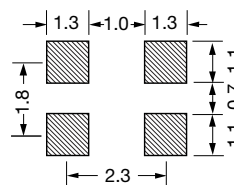

Figure 2) ECX-32 Land Pattern

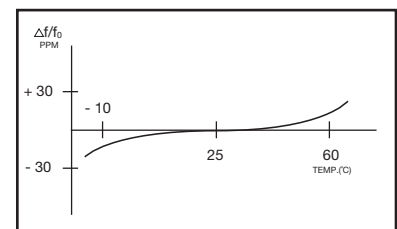
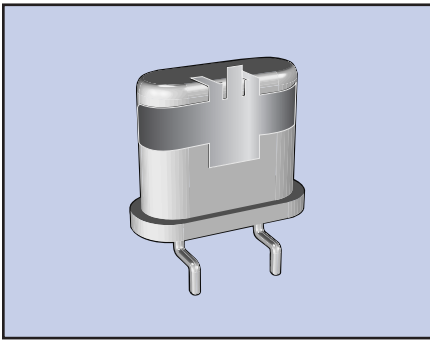

Figure 3) Frequency vs Temperature Curve



ECS offers all characteristics of the UM-1 with a metal jacket for surface mount applications. This crystal has a very wide frequency range from 3.6864MHz to 225MHz for use in wireless communication applications requiring tight tolerance specifications such as ± 5 PPM over -10°C to $+60^{\circ}\text{C}$.

FEATURES

- 3.6864MHz to 225MHz frequency range
- Very small foot print for critical space applications
- Resistance weld enclosure
- Low profile
- Tape & Reel (1,000 pcs)

PART NUMBERING GUIDE "EXAMPLE"

	FREQUENCY (16.0000 MHz)	LOAD CAPACITANCE*	PACKAGE TYPE
ECS	- 160	- 20	- 22 SMJ

* Load capacitance (xx=xx pF, S= series resonance)
 Note: See Product Selection Guide for additional options.

OPERATING CONDITIONS/ELECTRICAL CHARACTERISTICS

PARAMETERS	CONDITIONS	MINIMUM	TYPICAL	MAXIMUM	UNITS
FREQUENCY RANGE	f_0	3.6864		225.000	MHz
FREQUENCY TOLERANCE	3.6864MHz ~ 9.99MHz 10.000MHz ~ 225MHz	-50 -30		+50 +30	PPM
FREQUENCY STABILITY REFERENCE @ $+25^{\circ}\text{C}$	3.6864MHz ~ 9.99MHz 10.000MHz ~ 225MHz	-100 -50		+100 +50	PPM
SHUNT CAPACITANCE	C_0			5.0	pF
LOAD CAPACITANCE	C_L (Customer Specified)	10.0	20.0 standard	Series	pF
DRIVE LEVEL	3.6864MHz ~ 9.99MHz 10.000MHz ~ 225MHz	0.5 0.1		1.0 0.5	mW
AGING (@ $+25^{\circ}\text{C}$ per year)	3.6864MHz ~ 9.99MHz 10.000MHz ~ 225MHz	-5 -3		+5 +3	PPM
OPERATING TEMPERATURE	T_{OPR}	-10		+60	$^{\circ}\text{C}$
STORAGE TEMPERATURE	T_{STG}	-40		+85	$^{\circ}\text{C}$

EQUIVALENT SERIES RESISTANCE / MODE OF OSCILLATION

FREQUENCY RANGE (MHz)	MODE	MAX ESR Ω	FREQUENCY RANGE (MHz)	MODE	MAX ESR Ω
3.686 ~ 3.999	Fundamental	250	8.000 ~ 9.999	Fundamental	80
4.000 ~ 4.999	Fundamental	150	10.000 ~ 10.999	Fundamental	60
5.000 ~ 5.999	Fundamental	120	11.000 ~ 45.000	Fundamental	40
6.000 ~ 6.999	Fundamental	100	30.000 ~ 135.000	3rd O/T	40
7.000 ~ 7.999	Fundamental	90	100.000 ~ 225.000	5th O/T	80

PACKAGE DIMENSIONS (mm)

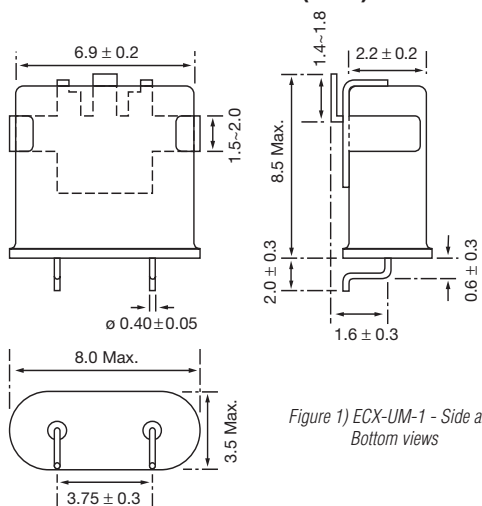

Figure 1) ECX-UM-1 - Side and Bottom views

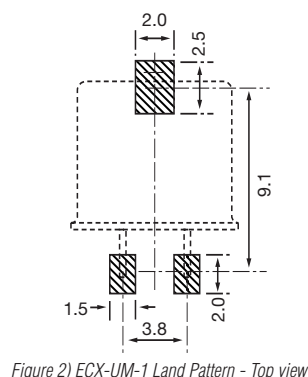

Figure 2) ECX-UM-1 Land Pattern - Top view

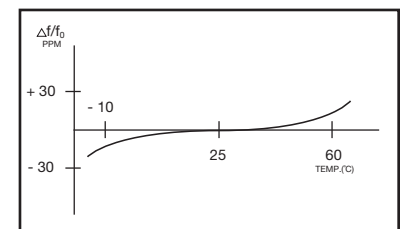

Figure 3) Frequency vs Temperature Curve

STANDARD CRYSTAL FREQUENCIES FOR THRU-HOLE AND SURFACE MOUNT PRODUCTS

FREQUENCY (MHz)	LOAD (pF)	HC-49/U	HC-49/S	CSM-7	ECX-3S	CSM-12
1.000	13	•				
1.8432	13	•				
1.8432	32	•				
1.8432	S	•				
2.000	20	•				
2.000	32	•				
2.000	S	•				
2.048	12	•				
2.4576	32	•				
2.4576	20	•				
2.500	S	•				
3.000	S	•				
3.2768	17	•				
3.579545	17	•	•	•	•	•
3.579545	S	•	•	•	•	
3.6864	18	•	•			
3.6864	S	•	•	•	•	•
3.6864	20		•	•	•	
3.93216	17	•				
4.000	20	•	•	•	•	•
4.000	S	•	•	•	•	•
4.032	20	•	•	•		
4.032	S	•	•	•		
4.096	20	•	•	•		
4.096	16				•	
4.194304	12	•	•	•	•	
4.194304	16		•	•		
4.433618	20	•	•	•	•	
4.9152	S	•	•	•	•	
4.9152	20	•	•	•	•	
5.000	S	•	•	•		
5.000	20	•	•	•	•	
5.0688	S	•	•	•		
5.0688	20	•	•	•		
5.185	S	•	•	•		
5.185	32	•	•	•		
5.9904	S	•	•	•		
5.9904	20	•	•	•		
6.000	S	•	•	•	•	
6.000	32	•	•	•	•	
6.000	20				•	
6.144	32	•	•	•	•	
6.500	20		•			
6.5536	12	•			•	
6.5536	S			•		
7.3728	S	•	•	•	•	•
7.3728	20	•	•	•	•	

F = FUNDAMENTAL

FREQUENCY (MHz)	LOAD (pF)	HC-49/U	HC-49/S	CSM-7	ECX-3S	CSM-12	CSM-8	ECX-64
7.680	20	•						
8.000	S	•	•	•	•	•		
8.000	18	•	•	•				
8.000	20	•	•					
8.000	32	•	•	•				
8.000	16				•			
8.192	S	•						
8.500	S	•						
9.000	S	•						
9.216	S	•	•	•				
9.216	20	•	•	•				
9.540	S		•					
9.8304	20	•	•	•	•	•		
9.8304	S	•	•	•	•	•		
10.000	S	•	•	•	•	•		
10.000	18		•	•				
10.738635	S	•	•					
11.000	S	•	•	•				
11.046	S	•						
11.0592	S	•	•	•	•	•	•	
11.0592	20	•	•	•	•	•	•	
11.0592	32	•	•	•	•	•	•	
11.0592	16		•					
11.228	S	•						
11.520	S	•	•					
11.520	18		•					
11.98135	S	•	•					
12.000	S	•	•	•	•	•	•	
12.000	32	•	•	•	•			
12.000	18			•	•			
12.000	20	•	•					
12.000393	18	•	•	•				
12.096	S	•	•					
12.288	S	•	•	•	•			
12.288	20	•	•	•	•			
12.960	12		•					
12.960	18		•					
13.5168	S	•						
14.31818	S	•	•	•	•	•	•	•
14.31818	20	•	•	•	•	•	•	
14.31818	18			•				
14.690	S	•						
14.7456	S	•	•	•	•	•	•	
14.7456	20	•	•	•	•			•
15.000	S	•	•	•				
15.360	20		•					
15.360	S	•						

OT = 3RD OT

FREQUENCY (MHz)	LOAD (pF)	HC-49/U	HC-49/S	CSM-7	ECX-3S	CSM-12	CSM-8	ECX-64
16.000	S	•	•	•	•	•	•	•
16.000	20	•	•	•	•	•		•
16.000	16		•					
16.000312	18	•	•	•				
16.257	20	•	•					
16.257	S	•	•					
16.9344	20	•	•					
17.734475	S	•						
18.000	S	•	•	•				
18.000	20	•	•	•				
18.432	S	•	•	•	•	•	•	•
18.432	18	•	•	•				
18.432	20	•	•	•				•
19.6608	S	•	•	•	•	•	•	•
19.6608	20	•	•	•	•			•
20.000	S	•	•	•	•	•	•	•
20.000	20	•	•	•	•	•	•	•
20.000	16			•				
20.000	18			•				
21.47727	S	•						
22.1184	S	•	•	•				
24.000 (F)	20	•	•	•	•	•	•	
24.000 (F)	S	•	•	•	•	•	•	•
24.000 (F)	16		•	•	•			
24.000 (F)	18			•				
24.00014 (F)	18	•	•	•				
24.00014 (F)	S						•	
30.000 (F)	S						•	
30.000 (OT)	S						•	
32.000 (F)	S						•	
32.000 (OT)	S						•	
33.000 (OT)	S						•	
33.8688 (F)	18						•	
35.2512 (OT)	18	•						
35.2512 (OT)	S						•	
36.000 (F)	S						•	
36.000 (OT)	S						•	
38.00053 (OT)	18	•						
40.000 (OT)	18		•					
40.000 (F)	S						•	
40.000 (OT)	S						•	
40.32 (OT)	18	•						
40.32 (OT)	20		•					
40.32 (F)	S			•				
40.32 (OT)	S						•	
48.00 (OT)	S	•						
49.86 (OT)	20	•						

S = SERIES RESONANCE

CUSTOMIZED OPTIONS FOR QUARTZ CRYSTALS

TOLERANCE @ +25°C	
CODE	TOLERANCE
A	±25 PPM
C	±10 PPM

TOLERANCE OVER TEMPERATURE	
CODE	TOLERANCE
D	±100 PPM
E	±50 PPM
G	±30 PPM
H	±25 PPM
K	±10 PPM

OPERATING TEMPERATURE	
CODE	TEMPERATURE RANGE
L	-10 ~ +70°C
M	-20 ~ +70°C
N	-40 ~ +85°C
P	-40 ~ +105°C
S	-40 ~ +125°C

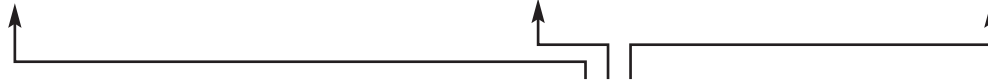

EXAMPLE P/N ECS-160-S-1-A-H-L

*VALUE ADDED SERVICES	
CODE	OPTION/DESCRIPTION
3L	THIRD LEAD
SL	SLEEVED
TR	TAPE AND REEL
B	INSULATOR
3IL	3RD IN LINE LEAD

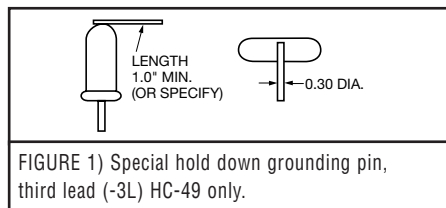

STANDARD DATE CODE CHART			
LETTER	MONTH	LETTER	MONTH
A	JAN	G	JUL
B	FEB	H	AUG
C	MAR	J	SEPT
D	APRIL	K	OCT
E	MAY	L	NOV
F	JUNE	M	DEC

* Thru-Hole Crystal Only.

Month/Year, G2=July, 2002

CRYSTAL MODE OF OPERATION: FUNDAMENTAL VS. OVERTONES
 Crystals over 24.0 MHz will be Overtone unless fundamental mode is requested. An "F" suffix in the P/N after the package type indicates a Fundamental mode i.e. ECS-300-S-I-F would be a 30.0 MHz Fundamental crystal.

ECS CROSS REFERENCE GUIDE CRYSTAL PART NUMBER TO DATA SHEET

P/N ECS-160-18-1

MANUFACTURER
ECS

FREQUENCY
160=16.0 MHz

LOAD CAPACITANCE
18=18 pF

PACKAGE/MODEL
1 = HC49U

PACKAGE/MODEL CROSS REFERENCE TABLE							
-7	ECX-3A	-9	3X9	-20A	CSM-8A	-23C	ECX-64C
-4	HC-49US (3.5mm)	-10	3X10	-20B	CSM-8B	-24	ECX-3TA
-4L	HC-49US (2.5mm)	-11	ECX-205	-20BM	CSM-8M	-25	UM-4
-5P	CSM-7 (4.3mm)	-13	2X6	-21	UM-5	-26	ECX-26
-5PL	CSM-7 (3.2mm)	-13FL	ECS-2X6-FL	-22	UM-1	-27	ECX-15
-6	ECX-206	-14	1X5	-22SMJ	ECX-UM-1	-28A	CSM-4A
-7S	ECX-3S	-14FL	ECS-1X5-FL	-23A	ECX-64A	-30	ECX-53
-8	3X8	-17/-17I	ECX-306/306I	-23B	ECX-64	-30B	ECX-53B
		-18	CSM-12			-32	ECX-31
		-19A	ECX-19A			-33	ECX-32

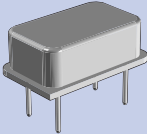
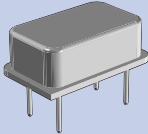
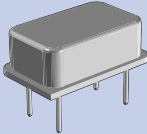
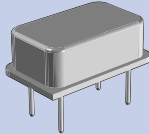
PRODUCT	ECS-100 SERIES	ECS-200 SERIES	ECS-400 SERIES	ECS-1000 SERIES
PRODUCT ILLUSTRATION				
FREQUENCY RANGE	1.0 ~ 150MHz	1.0 ~ 150MHz	250KHz ~ 150MHz	1.0 ~ 100MHz
FREQUENCY STABILITY	±100 PPM	±100 PPM	±100 PPM	±100 PPM
TEMPERATURE RANGE	0 ~ +70°C	0 ~ +70°C	0 ~ +70°C	0 ~ +70°C
FEATURES	<ul style="list-style-type: none"> • 10 TTL • Cost Effective • Wide Frequency Range • 14 Pin DIP Package 	<ul style="list-style-type: none"> • HCMOS/TTL • Low Current Drain • Cost Effective • Tight Tolerance • 14 Pin DIP Package 	<ul style="list-style-type: none"> • HCMOS/TTL • 55/45 Symmetry • Low Current Drain • Wide Frequency Range • 14 Pin DIP Package 	<ul style="list-style-type: none"> • HCMOS/TTL • Tri-State • 55/45 Symmetry • Wide Frequency Range • 14 Pin DIP Package
PAGE #	32	33	34	35

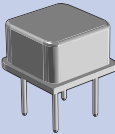
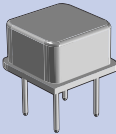
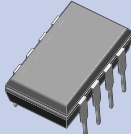
PRODUCT	ECS-2100 SERIES	ECS-2200 SERIES	ECS-300C SERIES
PRODUCT ILLUSTRATION			
FREQUENCY RANGE	1.0 ~ 150 MHz	1.0 ~ 150 MHz	12 ~ 32 MHz
FREQUENCY STABILITY	±100 PPM	±100 PPM	±100 PPM
TEMPERATURE RANGE	0 ~ +70°C	0 ~ +70°C	-10 ~ +70°C
FEATURES	<ul style="list-style-type: none"> • HCMOS/TTL • 55/45 Symmetry • Low Current Drain • 8 Pin DIP Package 	<ul style="list-style-type: none"> • HCMOS/TTL • 55/45 Symmetry • Low Current Drain • Tri-State • 8 Pin DIP Package 	<ul style="list-style-type: none"> • Dual CMOS Output • Low Current Drain • 1.5 ms Start Up • 3V - 5V Supply Voltage • 8 Pin DIP Package
PAGE #	36	37	38

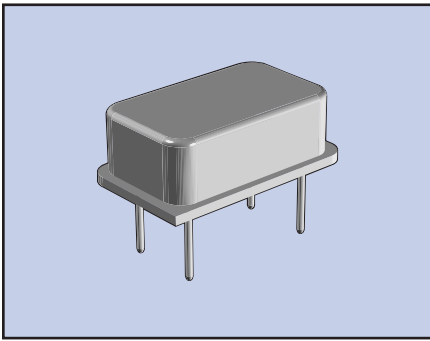

The ECS-100 clock oscillator is fully compatible with TTL circuitry. The metal package with pin #7 case ground acts as shielding to minimize radiation.

FEATURES

- 10 TTL output load
- Low cost
- Wide frequency range
- Industry standard footprint
- Resistance weld package
- 3.3V operation (optional)

PART NUMBERING GUIDE

PART NUMBER *	FREQUENCY STABILITY
ECS-100A	±100 PPM
ECS-100B	±50 PPM
ECS-100C	±25 PPM

* Complete part number to include frequency. i.e. ECS-100A-100 (100 = 10.000MHz)

OPERATING CONDITIONS/ELECTRICAL CHARACTERISTICS

PARAMETERS	FREQUENCY RANGE	CONDITIONS	MINIMUM	TYPICAL	MAXIMUM	UNITS
FREQUENCY RANGE (f ₀)	1.000 ~ 150.000		1.000		150.000	MHz
OPERATING TEMP. RANGE (T _{OPR})	1.000 ~ 150.000		0		+70	°C
STORAGE TEMP. RANGE (T _{STG})	1.000 ~ 150.000		-55		+125	°C
FREQUENCY STABILITY	1.000 ~ 150.000	All conditions*	-100		+100	PPM
INPUT CURRENT (I _{DD})	1.000 ~ 7.999	max. load			15	mA
	8.000 ~ 23.999	max. load			30	mA
	24.000 ~ 69.999	max. load			70	mA
	70.000 ~ 150.000	max. load			80	mA
OUTPUT SYMMETRY	1.000 ~ 7.999	1.4V level	45	50 ±3	55	%
	8.000 ~ 150.000	1.4V level	40	50 ±3	60	%
RISE TIME (T _R)	1.000 ~ 24.999	0.4V ~ 2.4V			10	nS
	25.000 ~ 69.999	0.5V ~ 2.4V			5	nS
	70.000 ~ 150.000	0.5V ~ 2.4V			4	nS
FALL TIME (T _F)	1.000 ~ 24.999	2.4V ~ 0.4V			10	nS
	25.000 ~ 69.999	2.4V ~ 0.5V			5	nS
	70.000 ~ 150.000	2.4V ~ 0.5V			4	nS
OUTPUT VOLTAGE	(V _{OL})	1.000 ~ 24.999	I _{OL} = 20 mA		0.4	V
	(V _{OL})	25.000 ~ 150.000	I _{OL} = 20 mA		0.5	V
	(V _{OH})	70.000 ~ 150.000	I _{OH} = 1 mA	2.4		V
OUTPUT CURRENT	(I _{OL})	1.000 ~ 150.000	V _{OL} = 0.5 V		20	mA
	(I _{OH})	1.000 ~ 150.000	V _{OH} = 2.4 V		1.0	mA
OUTPUT LOAD	1.000 ~ 150.000				10	TTL
START-UP TIME (T _s)	1.000 ~ 3.499				20	mS
	3.500 ~ 3.999				35	mS
	4.000 ~ 5.999				30	mS
	6.000 ~ 19.999				20	mS
	20.000 ~ 150.000				15	mS
SUPPLY VOLTAGE	1.000 ~ 150.000	+5.0 ±0.25			-	V _{DC}

* Inclusive of 25°C tolerance, operating temperature range, input voltage change, load change, aging, shock and vibration.

PACKAGE DIMENSIONS (mm)

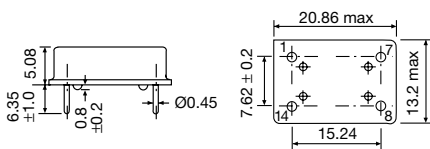

Figure 1) ECS-100 Series Side and Bottom views



Figure 2) Output Wave Form

PIN CONNECTIONS	
#1	NC
#7	CASE GND
#8	OUTPUT
#14	+5 V DC

Figure 3) Pin Connections

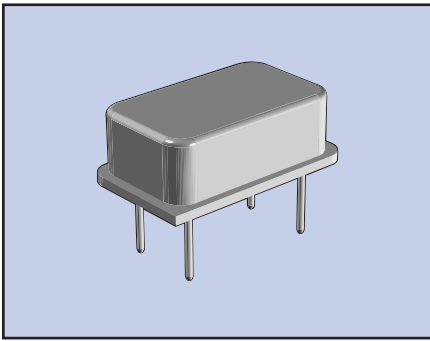

The ECS-200 Series clock oscillator offers low current drain and is compatible with HCMOS/LSTTL logic. It is ideal for low power HCMOS applications. The metal package with pin #7 case ground acts as shielding to minimize radiation.

FEATURES

- HCMOS/LSTTL logic compatible
- Wide frequency range
- Low power consumption
- Resistance weld package
- 3.3V operation (optional)

PART NUMBERING GUIDE

PART NUMBER *	FREQUENCY STABILITY
ECS-200A	±100 PPM
ECS-200B	±50 PPM
ECS-200C	±25 PPM

* Complete part number to include frequency. i.e. ECS-200A-100 (100 = 10.000MHz)

OPERATING CONDITIONS/ELECTRICAL CHARACTERISTICS

PARAMETERS	FREQUENCY RANGE	CONDITIONS	MINIMUM	TYPICAL	MAXIMUM	UNITS
FREQUENCY RANGE (f_0)	1.000 ~ 150.000		1.000		150.000	MHz
OPERATING TEMP. RANGE (T_{OPR})	1.000 ~ 150.000		0		+70	°C
STORAGE TEMP. RANGE (T_{STG})	1.000 ~ 150.000		-55		+125	°C
FREQUENCY STABILITY	1.000 ~ 150.000	All conditions*	-100		+100	PPM
INPUT CURRENT (I_{DD})	1.000 ~ 20.000				12	mA
	20.000 ~ 25.000				15	mA
	25.000 ~ 150.000				30	mA
OUTPUT SYMMETRY		50% V_{DD} level	45	50 ±3	55	%
RISE TIME (T_R)	1.000 ~ 25.000	10% ~ 90% V_{DD} level			10	nS
	25.000 ~ 150.000	10% ~ 90% V_{DD} level			5	nS
FALL TIME (T_F)	1.000 ~ 25.000	90% ~ 10% V_{DD} level			10	nS
	25.000 ~ 150.000	90% ~ 10% V_{DD} level			5	nS
OUTPUT VOLTAGE (V_{OL}) (V_{OH})	1.000 ~ 150.000	$I_{OL} = 4$ mA			0.5	V
	1.000 ~ 150.000	$I_{OH} = -4$ mA	4.5			V
OUTPUT CURRENT (I_{OL}) (I_{OH})	1.000 ~ 150.000	$V_{OL} = 0.5$ V			4	mA
	1.000 ~ 150.000	$V_{OH} = 4.5$ V			-4	mA
OUTPUT LOAD	1.000 ~ 3.500	HCMOS/LSTTL			15	pF
	3.510 ~ 150.000	HCMOS/LSTTL			50	pF
START-UP TIME (T_s)	1.000 ~ 25.000				5	mS
	25.000 ~ 150.000				10	mS
SUPPLY VOLTAGE	1.000 ~ 150.000	+5.0 ±0.25				V _{DC}

* Inclusive of 25°C tolerance, operating temperature range, input voltage change, load change, aging, shock and vibration.

PACKAGE DIMENSIONS (mm)

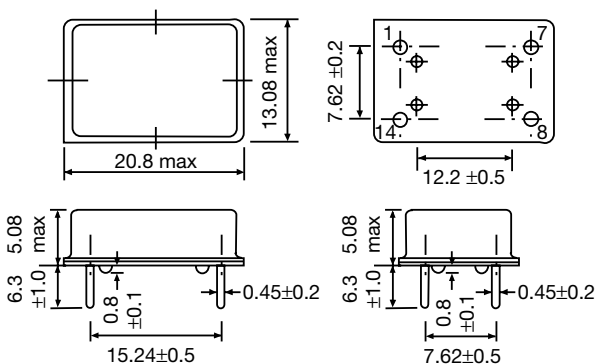

Figure 1) ECS-200 Series – Top, Bottom and Side views

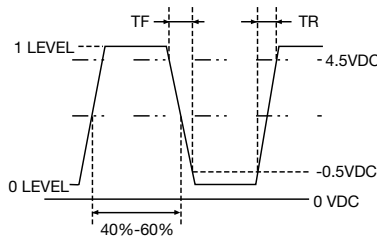
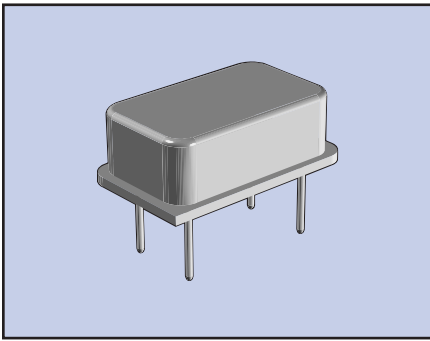

Figure 2) Output Wave Form

PIN CONNECTIONS	
#1	NC
#7	CASE GND
#8	OUTPUT
#14	+5 V DC

Figure 3) Pin Connection



The ECS-400 Series clock oscillator offers low current drain and is compatible with HCMOS/TTL logic. The metal package with pin #7 case ground acts as shielding to minimize radiation.

FEATURES

- HCMOS/TTL logic compatible
- Wide frequency range
- Low power consumption
- Resistance weld package
- 3.3V operation (optional)

PART NUMBERING GUIDE

PART NUMBER *	FREQUENCY STABILITY
ECS-400A	±100 PPM
ECS-400B	±50 PPM
ECS-400C	±25 PPM

* Complete part number to include frequency. i.e. ECS-400A-100 (100 = 10.000MHz)

OPERATING CONDITIONS/ELECTRICAL CHARACTERISTICS

PARAMETERS	FREQUENCY RANGE	CONDITIONS	MINIMUM	TYPICAL	MAXIMUM	UNITS
FREQUENCY RANGE (f_0)	.250 ~ 150.000		.250		150.000	MHz
OPERATING TEMP. RANGE (T_{OPR})	.250 ~ 150.000		0		+70	°C
STORAGE TEMP. RANGE (T_{STG})	.250 ~ 150.000		-55		+125	°C
FREQUENCY STABILITY	.250 ~ 150.000	All conditions*	-100		+100	PPM
INPUT CURRENT (I_{DD})	.250 ~ 20.000				12	mA
	20.000 ~ 25.000				15	mA
	25.000 ~ 150.000				30	mA
OUTPUT SYMMETRY		50% V_{DD} level	40	50 ±3	60	%
RISE TIME (T_R)	.250 ~ 25.000	10% ~ 90% V_{DD} level			10	nS
	25.000 ~ 150.000	10% ~ 90% V_{DD} level			5	nS
FALL TIME (T_F)	.250 ~ 25.000	90% ~ 10% V_{DD} level			10	nS
	25.000 ~ 150.000	90% ~ 10% V_{DD} level			5	nS
OUTPUT VOLTAGE (V_{OL}) (V_{OH})	.250 ~ 150.000	$I_{OL} = 4$ mA			0.5	V
	.250 ~ 150.000	$I_{OH} = -4$ mA	4.5			V
OUTPUT CURRENT (I_{OL}) (I_{OH})	.250 ~ 150.000	$V_{OL} = 0.5$ V			4	mA
	.250 ~ 150.000	$V_{OH} = 4.5$ V			-4	mA
OUTPUT LOAD	.250 ~ 150.000	TTL			10	TTL
	.250 ~ 150.000	HCMOS			15	pF
START-UP TIME (T_s)	.250 ~ 25.000				5	mS
	25.000 ~ 150.000				10	mS
SUPPLY VOLTAGE		+5.0 ±0.25				V

* Inclusive of 25°C tolerance, operating temperature range, input voltage change, load change, aging, shock and vibration.

PACKAGE DIMENSIONS (mm)

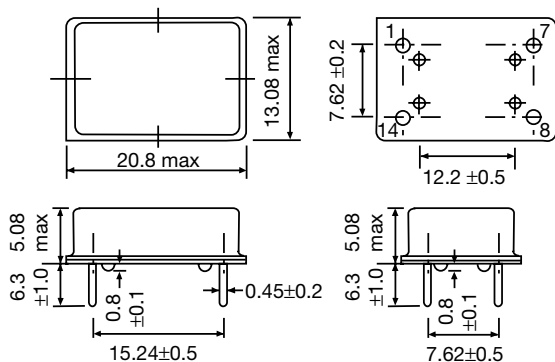

Figure 1) ECS-400 Series – Top, Bottom and Side views

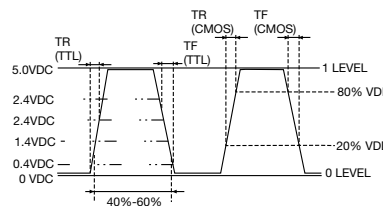
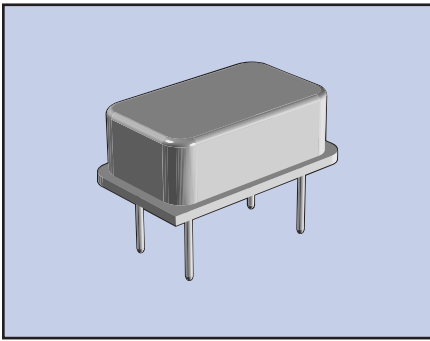

Figure 2) Output Wave Form

PIN CONNECTIONS	
#1	NC
#7	CASE GND
#8	OUTPUT
#14	+5 V DC



The ECS-1000 Series clock oscillator can drive both HCMOS and TTL logic. This oscillator also features tri-state enable/disable capabilities in a 14 pin DIP package.

FEATURES

- 50pF HCMOS/ TTL logic
- Tri-State enable/disable
- Wide frequency range
- Resistance weld package
- 3.3V operation (optional)

PART NUMBERING GUIDE

PART NUMBER *	FREQUENCY STABILITY
ECS-1000A	±100 PPM
ECS-1000B	±50 PPM
ECS-1000C	±25 PPM

* Complete part number to include frequency. i.e. ECS-1000A-100 (100 = 10.000MHz)

OPERATING CONDITIONS/ELECTRICAL CHARACTERISTICS

PARAMETERS	FREQUENCY RANGE	CONDITIONS	MINIMUM	TYPICAL	MAXIMUM	UNITS
FREQUENCY RANGE (f_0)	1.000 ~ 100.000		1.000		100.000	MHz
OPERATING TEMP. RANGE (T_{OPR})	1.000 ~ 100.000		0		+70	°C
STORAGE TEMP. RANGE (T_{STG})	1.000 ~ 100.000		-55		+125	°C
FREQUENCY STABILITY	1.000 ~ 100.000	All conditions*	-100		+100	PPM
INPUT CURRENT (I_{DD})	1.000 ~ 25.000			17	25	mA
	25.000 ~ 50.000			33	40	mA
	50.000 ~ 80.000			45	77	mA
	80.000 ~ 100.000			67	82	mA
OUTPUT SYMMETRY	1.000 ~ 80.000	50% V_{DD} level	45	50 ±3	55	%
	80.000 ~ 100.000	50% V_{DD} level	40	50 ±3	60	%
RISE TIME (T_R)	1.000 ~ 100.000	10% ~ 90% V_{DD} level			5	nS
FALL TIME (T_F)	1.000 ~ 100.000	90% ~ 10% V_{DD} level			5	nS
OUTPUT VOLTAGE (V_{OL}) (V_{OH})	1.000 ~ 100.000	$I_{OL} = 16$ mA			0.5	V
	1.000 ~ 100.000	$I_{OH} = -16$ mA	4.5			V
OUTPUT CURRENT (I_{OL}) (I_{OH})	1.000 ~ 100.000	$V_{OL} = 0.5$ V			16	mA
	1.000 ~ 100.000	$V_{OH} = 4.5$ V			-16	mA
OUTPUT LOAD	1.000 ~ 100.000	TTL			10	pF
	1.000 ~ 80.000	HCMOS			50	pF
	80.000 ~ 100.000	HCMOS			30	pF
START-UP TIME (T_s)	1.000 ~ 100.000				10	mS
SUPPLY VOLTAGE		+5.0 ±0.25				V

* Inclusive of 25°C tolerance, operating temperature range, input voltage change, load change, aging, shock and vibration.

** An internal pullup resistor from pin 1 to pin 14 allows active output if pin 1 is left open.

PACKAGE DIMENSIONS (mm)

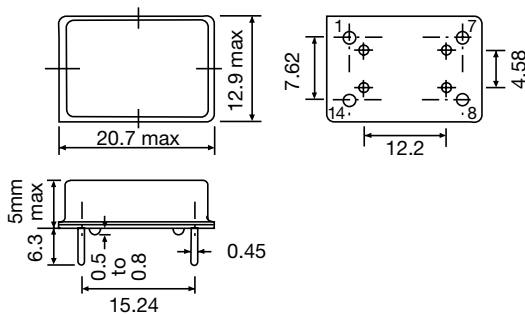

Figure 1) ECS-1000 Series – Top, Bottom and Side views

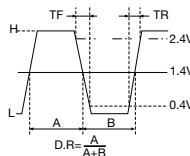

Figure 2) TTL Output Wave Form

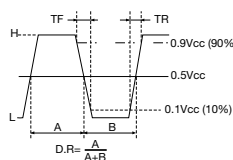
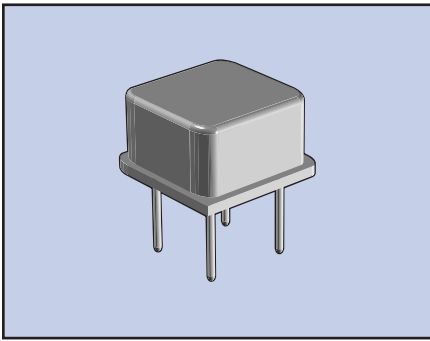

Figure 3) HCMOS Output Wave Form

PIN CONNECTIONS	
#1	TRI-STATE
#7	CASE GROUND
#8	OUTPUT
#14	+5V DC

ENABLE / DISABLE FUNCTION**	
\overline{INH} (PIN 1)	OUTPUT (PIN 8)
OPEN**	ACTIVE
1 LEVEL $V_{IH} \geq 2.2$ V ($V_{IH} \geq 2.0$ V ABOVE 70MHz)	ACTIVE
'0' LEVEL $V_{IL} \leq 0.8$ V	HIGH Z



The ECS-2100 Series clock oscillator offers low current drain and is compatible with HCMOS/TTL logic. The metal package with pin #4 case ground acts as a shielding to minimize radiation.

FEATURES

- HCMOS/TTL logic compatible
- Wide frequency range
- Low power consumption
- Resistance weld package
- 3.3V operation (optional)

PART NUMBERING GUIDE

PART NUMBER *	FREQUENCY STABILITY
ECS-2100A	±100 PPM
ECS-2100B	±50 PPM
ECS-2100C	±25 PPM

* Complete part number to include frequency. i.e. ECS-2100A-100 (100 = 10.000MHz)

OPERATING CONDITIONS/ELECTRICAL CHARACTERISTICS

PARAMETERS	FREQUENCY RANGE	CONDITIONS	MINIMUM	TYPICAL	MAXIMUM	UNITS
FREQUENCY RANGE (f_0)	1.000 ~ 150.000		1.000		150.000	MHz
OPERATING TEMP. RANGE (T_{OPR})	1.000 ~ 150.000		0		+70	°C
STORAGE TEMP. RANGE (T_{STG})	1.000 ~ 150.000		-55		+125	°C
FREQUENCY STABILITY	1.000 ~ 150.000	All conditions*	-100		+100	PPM
INPUT CURRENT (I_{DD})	1.000 ~ 25.000			17	25	mA
	25.000 ~ 50.000			33	46	mA
	50.000 ~ 80.000			45	77	mA
	80.000 ~ 150.000			67	82	mA
OUTPUT SYMMETRY	1.000 ~ 80.000	50% V_{DD} level	45	50 ±3	55	%
	80.000 ~ 150.000	50% V_{DD} level	40	50 ±3	60	%
RISE TIME (T_R)	1.000 ~ 150.000	10% ~ 90% V_{DD} level			5	nS
FALL TIME (T_F)	1.000 ~ 150.000	90% ~ 10% V_{DD} level			5	nS
OUTPUT VOLTAGE (V_{OL}) (V_{OH})	1.000 ~ 150.000	$I_{OL} = 16$ mA			0.5	V
	1.000 ~ 150.000	$I_{OH} = -16$ mA	4.5			V
OUTPUT CURRENT (I_{OL}) (I_{OH})	1.000 ~ 100.000	$V_{OL} = 0.5$ V			16	mA
	1.000 ~ 150.000	$V_{OH} = 4.5$ V			-16	mA
OUTPUT LOAD	1.000 ~ 150.000	TTL			10	TTL
	1.000 ~ 80.000	HCMOS			50	pF
	80.000 ~ 150.000	HCMOS			30	pF
START-UP TIME (T_s)	1.000 ~ 150.000	0.0V TO 5.0V			10	mS
SUPPLY VOLTAGE (V_{DC})		+5.0 ±0.25				V _{DC}

* Inclusive of 25°C tolerance, operating temperature range, input voltage change, load change, aging, shock and vibration.

PACKAGE DIMENSIONS (mm)

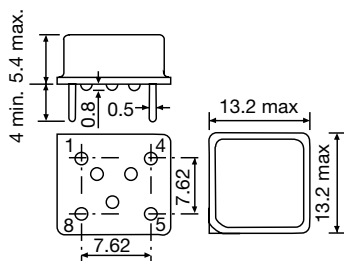

Figure 1) ECS-2100 Series – Side, Bottom and Top views

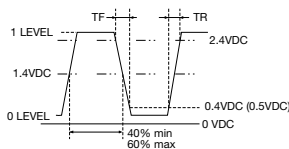

Figure 2) TTL Output Wave Form

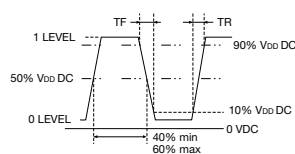
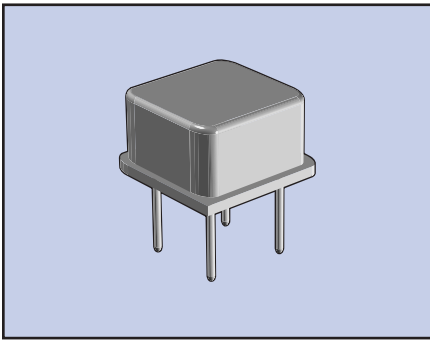

Figure 3) HCMOS Output Wave Form

PIN CONNECTIONS	
#1	NC
#4	GROUND
#5	OUTPUT
#8	+5V DC



The ECS-2200 Series clock oscillator can drive both HCMOS and TTL logic. This oscillator also features tri-state enable/disable capabilities in an 8 pin DIP package.

FEATURES

- 50pF HCMOS/TTL logic
- Tri-State enable/disable
- Wide frequency range
- Resistance weld package
- 3.3V operation (optional)

PART NUMBERING GUIDE

PART NUMBER *	FREQUENCY STABILITY
ECS-2200A	±100 PPM
ECS-2200B	±50 PPM
ECS-2200C	±25 PPM

* Complete part number to include frequency. i.e. ECS-2200A-100 (100 = 10.000MHz)

OPERATING CONDITIONS/ELECTRICAL CHARACTERISTICS

PARAMETERS	FREQUENCY RANGE	CONDITIONS	MINIMUM	TYPICAL	MAXIMUM	UNITS
FREQUENCY RANGE (f_0)	1.000 ~ 150.000		1.000		150.000	MHz
OPERATING TEMP. RANGE (T_{OPR})	1.000 ~ 150.000		0		+70	°C
STORAGE TEMP. RANGE (T_{STG})	1.000 ~ 150.000		-55		+125	°C
FREQUENCY STABILITY	1.000 ~ 150.000	All conditions*	-100		+100	PPM
INPUT CURRENT (I_{DD})	1.000 ~ 25.000			17	25	mA
	25.000 ~ 50.000			33	46	mA
	50.000 ~ 80.000			45	77	mA
	80.000 ~ 150.000			67	82	mA
OUTPUT SYMMETRY	1.000 ~ 80.000	50% V_{DD} level	45	50 ±3	55	%
	80.000 ~ 150.000	50% V_{DD} level	40	50 ±3	60	%
RISE TIME (T_R)	1.000 ~ 150.000	10% ~ 90% V_{DD} level			5	nS
FALL TIME (T_F)	1.000 ~ 150.000	90% ~ 10% V_{DD} level			5	nS
OUTPUT VOLTAGE (V_{OL}) (V_{OH})	1.000 ~ 150.000	$I_{OL} = 16$ mA			0.5	V
	1.000 ~ 150.000	$I_{OH} = -16$ mA	4.5			V
OUTPUT CURRENT (I_{OL}) (I_{OH})	1.000 ~ 150.000	$V_{OL} = 0.5$ V			16	mA
	1.000 ~ 150.000	$V_{OH} = 4.5$ V			-16	mA
OUTPUT LOAD	1.000 ~ 150.000	TTL			10	TTL
	1.000 ~ 80.000	HCMOS			50	pF
	80.000 ~ 150.000	HCMOS			30	pF
START-UP TIME (T_s)	1.000 ~ 150.000	0.0V TO 5.0V			10	mS
SUPPLY VOLTAGE (V_{DC})		+5.0 ±0.25				V _{DC}

* Inclusive of 25°C tolerance, operating temperature range, input voltage change, load change, aging, shock and vibration.

** An internal pullup resistor from pin 1 to pin 8 allows active output if pin 1 is left open.

PACKAGE DIMENSIONS (mm)

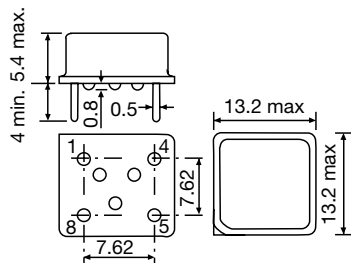

Figure 1) ECS-2200 Series – Side, Bottom and Top views

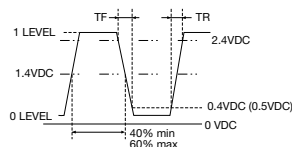

Figure 2) TTL Output Wave Form

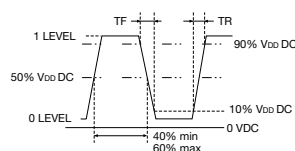
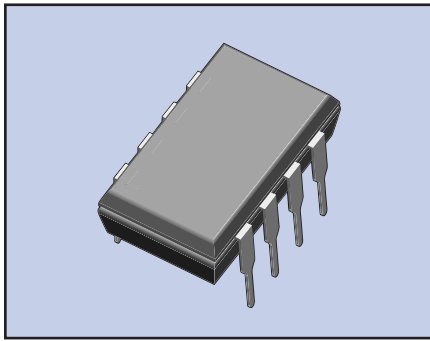

Figure 3) HCMOS Output Wave Form

PIN CONNECTIONS	
#1	TRI-STATE
#4	CASE GROUND
#5	OUTPUT
#8	+5V DC

ENABLE / DISABLE FUNCTION**	
INH (PIN 1)	OUTPUT (PIN 5)
OPEN**	ACTIVE
1 LEVEL $V_{IH} \geq 2.2$ V ($V_{IH} \geq 2.0$ V ABOVE 70MHz)	ACTIVE
'0' LEVEL $V_{IL} \leq 0.8$ V	HIGH Z



The ECS-300C utilizes a built in divider circuit to provide a second divided output. The CMOS based oscillator features low current consumption in a standard 8-pin DIP package.

FEATURES

- Low current consumption
- Built in divider circuit
- 8-pin DIP package

PART NUMBERING GUIDE

SERIES	FREQUENCY (12.000 MHz)
ECS-300C	120

Sample Part Number: ECS-300C-120

STANDARD FREQUENCIES

12.000, 12.288, 12.800, 14.31818, 14.7456, 15.9744, 16.000, 16.384, 17.734476, 18.432, 19.6608, 20.000, 24.000, 24.576, 30.000 AND 32.000 MHz

OPERATING CONDITIONS/ELECTRICAL CHARACTERISTICS

PARAMETERS	CONDITIONS	MINIMUM	TYPICAL	MAXIMUM	UNITS
FREQUENCY RANGE	Primary Output	12.000		32.000	MHz
	Divided Output*	48.875 KHz		16.000 MHz	
FREQUENCY STABILITY	All Conditions			±100*	PPM
OPERATING TEMPERATURE		-10°		+70°	°C
STORAGE TEMPERATURE		-55°		+125°	°C
INPUT VOLTAGE (V _{CC})		+3.0V	+5.0V	+5.5V	V DC
INPUT CURRENT				20	mA
OUTPUT SYMMETRY	Primary Output	40/60		60/40	%
	Divided Output	48/52		52/48	%
RISE AND FALL TIMES				15	ns
OUTPUT VOLTAGE	V _{OL}			V _{CC} x 0.1	V DC
	V _{OH}	V _{CC} x 0.9			V DC
OUTPUT LOAD	12.000 ~ 24.576 MHz			50	pF
	30.000 ~ 32.000 MHz			15	pF
START UP TIME	12.000 ~ 24.576 MHz			1.5	mS
	30.000 ~ 32.000 MHz			2.0	mS

*See Possible Frequency Divisions Table for example of divided frequencies.

POSSIBLE FREQUENCY DIVISIONS BY PART NUMBER

ECS PART NUMBER	fo CLOCK PIN 1	fo/2 ⁿ (Divided Output) PIN 2							
		1/2 ¹	1/2 ²	1/2 ³	1/2 ⁴	1/2 ⁵	1/2 ⁶	1/2 ⁷	1/2 ⁸
ECS-300C-120	12.000 MHz	6.000 MHz	3.000 MHz	1.500 MHz	750 KHz	375 KHz	187.5 KHz	93.75 KHz	46.875 KHz
ECS-300C-163	16.384 MHz	8.192 MHz	4.096 MHz	2.048 MHz	1.024 MHz	512 KHz	256 KHz	128 KHz	64 KHz
ECS-300C-320	32.000 MHz	16.000 MHz	8.000 MHz	4.000 MHz	2.000 MHz	1.000 MHz	500 KHz	250 KHz	125 KHz

DIMENSIONS (mm)

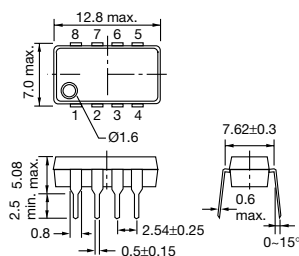

Figure 1) ECS-300C Top and Side views

PIN CONNECTIONS	
#1	OUTPUT
#2	DIVIDED OUTPUT
#3	STANDBY
#4	GND
#5	A (Divider selection)
#6	B (Divider selection)
#7	C (Divider selection)
#8	V _{CC}

Figure 2) Pin Connections

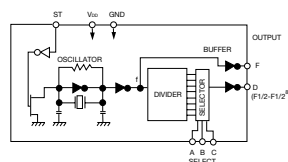
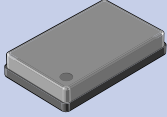
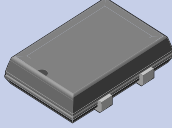
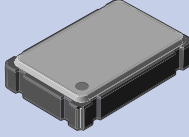
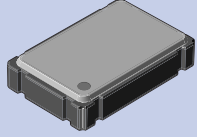
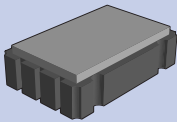
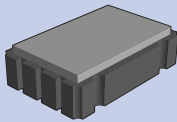
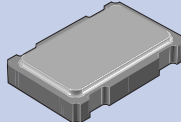

Figure 3) ECS-300C Block Diagram

Input				Output	
Divider Selection				PIN 1(Primary Output)	PIN 2(Divided Output)
C	B	A	ST		
X	X	X	L	L	L
L	L	L	H	fo clock	fo 1/2 ¹ clock
L	L	H	H	fo clock	fo 1/2 ² clock
L	H	L	H	fo clock	fo 1/2 ³ clock
L	H	H	H	fo clock	fo 1/2 ⁴ clock
H	L	L	H	fo clock	fo 1/2 ⁵ clock
H	L	H	H	fo clock	fo 1/2 ⁶ clock
H	H	L	H	fo clock	fo 1/2 ⁷ clock
H	H	H	H	fo clock	fo 1/2 ⁸ clock

Figure 4) Divided Output Selection Table

PRODUCT	ECS-327SM0	ECS-8F	ECS-3951C/3953C	ECS-3955C
PRODUCT ILLUSTRATION				
FREQUENCY RANGE	32.768 KHz	1.0 ~ 80.000 MHz	1.8 MHz ~ 80 MHz	1.8 ~ 66.666 MHz
FREQUENCY STABILITY	-60/+30 PPM	±100 PPM	±100 PPM	±100 PPM
TEMPERATURE RANGE	-10 ~ +60°C	-10 ~ +70°C	0 ~ +70°C	0 ~ +70°C
FEATURES	<ul style="list-style-type: none"> • 4 x 6.5 mm Footprint • HCMOS • 3.3 V Version 	<ul style="list-style-type: none"> • HCMOS/TTL • 55/45 Symmetry • Tri-State, EN/DS • Extended Temp Range • 3V & 5V Versions 	<ul style="list-style-type: none"> • HCMOS/TTL • 1.6 mm Profile • ±50 & ±30 PPM Options • Ceramic Package • Tri-State • 3V & 5V Versions 	<ul style="list-style-type: none"> • HCMOS/TTL • High Output Load • ±50 & ±30 PPM Options • 1.6 mm Profile • Multi-Volt Versions • Tri-State
PAGE #	40	41	42	43

PRODUCT	ECS-3951M/3953M	ECS-3955M	ECS-3961/3963
PRODUCT ILLUSTRATION			
FREQUENCY RANGE	1.8 ~ 125 MHz	1.8 ~ 70 MHz	2.5 ~ 66.666 MHz
FREQUENCY STABILITY	±100 PPM	±100 PPM	±100 PPM
TEMPERATURE RANGE	-10 ~ +70°C	-10 ~ +70°C	-10 ~ +70°C
FEATURES	<ul style="list-style-type: none"> • HCMOS/TTL • ±50 & ±30 PPM Options • 1.6 mm Profile • Tri-State • 3V & 5V Versions • Seam Welded Package 	<ul style="list-style-type: none"> • HCMOS/TTL • High Output Load • ±50 & ±30 PPM Options • 1.6 mm Profile • Tri-State • 3V & 5V Versions 	<ul style="list-style-type: none"> • HCMOS/TTL • ±50 & ±30 PPM Options • 1.0 mm Profile • Tri-State • 3.2 x 5 mm Footprint • 3V & 5V Versions
PAGE #	44	45	46

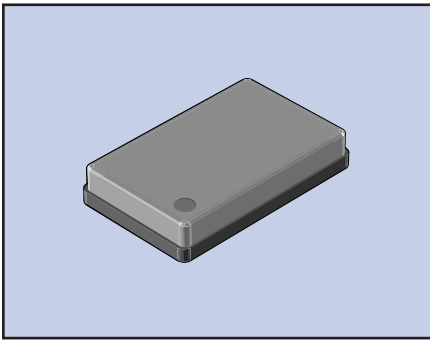

The ECS-327SMO oscillator utilizes the 32.768 KHz tuning fork crystal in a SMD ceramic package. It is designed specifically for wireless PCMCIA and portable communication equipment applications.

FEATURES

- 2.0 mm low profile
- SMD version
- 3.3V input voltage
- Tape & Reel (1000 pcs)

PART NUMBERING GUIDE

PART NUMBER *
ECS-327SMO

OPERATING CONDITIONS/ELECTRICAL CHARACTERISTICS

PARAMETERS	CONDITIONS	MINIMUM	TYPICAL	MAXIMUM	UNITS
OUTPUT FREQUENCY			32.768		KHz
FREQUENCY STABILITY	-10 ~ +60°C	-60		+30	PPM
FREQUENCY STABILITY	-40 ~ +85°C	-140		+30	PPM
OPERATING TEMPERATURE		-40		+85	°C
STORAGE TEMPERATURE		-40		+85	°C
INPUT VOLTAGE V_{CC}		+1.8V	+3.3V	+5.0V	V DC
INPUT CURRENT	with 15 pF load		8	15	μ A
SYMMETRY	at 1/2 V_{CC} level and +25°C	45/55		55/45	%
RISE AND FALL TIMES				200	ns
"0" LEVEL				$V_{CC} \times 0.1V$	
"1" LEVEL		$V_{CC} \times 0.9V$			
LOAD	CMOS			15	pF

PACKAGE DIMENSIONS (mm)

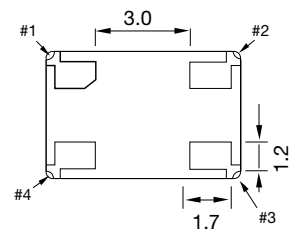
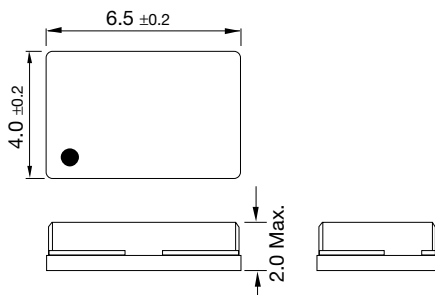

Figure 1) ECS-327SMO – Top, Bottom and Side views

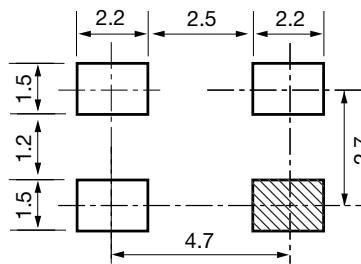
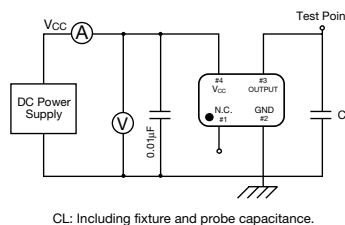

Figure 2) Land Pattern

PIN CONNECTIONS	
#1	NC
#2	GND
#3	OUTPUT
#4	V_{CC}

PACKAGE DATA	
COVER	METAL
BASE	CERAMIC
TERMINAL PLATING	GOLD



CL: Including fixture and probe capacitance.

Figure 3) Test Circuit

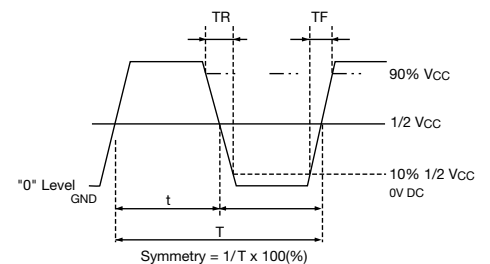
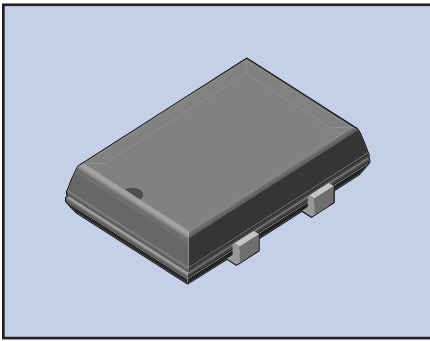

Figure 4) Output Wave Form



The ECS-8FM (5V) and ECS-8FA3 (3.3V) are CMOS compatible, J-leaded SMD oscillators. The 8F Series utilizes a low power CMOS IC in a cost effective package suitable for reflow soldering.

FEATURES

- 5.0V & 3.3V versions
- Extended temperature range
- Tri-State function
- Tape and Reel (1,000 pcs STD)

PART NUMBERING GUIDE

ECS-8FM	FREQUENCY (50.0 MHz)	TAPE AND REEL
-	500	- TR

Sample Part Number: ECS-8FM-500-TR

OPERATING CONDITIONS/ELECTRICAL CHARACTERISTICS

PARAMETERS	CONDITIONS	ECS-8FM (5V)			ECS-8FA3 (3.3V)			UNITS
		MIN	TYP	MAX	MIN	TYP	MAX	
FREQUENCY RANGE		1.000		80.000	1.000		80.000	MHz
TEMPERATURE RANGE	Operating	-40°		+85°	-40°		+85°	°C
	Storage	-55°		+125°	-55°		+125°	°C
SUPPLY VOLTAGE		+4.5	+5.0	+5.5	+3.0	+3.3	+3.6	V DC
FREQUENCY TOLERANCE*	-10 ~ +70°C			±100			±100	PPM
	-40 ~ 85°C			±200			±200	PPM
INPUT CURRENT	1.0 ~ 30.0 MHz			23			9	mA
	30.1 ~ 80.0 MHz			35			20	mA
OUTPUT SYMMETRY	@ 1/2 V _{CC} Level	40/60		60/40	45/55		55/45	%
RISE AND FALL TIMES	1.0 ~ 30.0 MHz			8			6	ns
	30.1 ~ 80.0 MHz			7			6	ns
OUTPUT VOLTAGE	V _{OL}			+0.5			+0.4	V
	V _{OH}	V _{CC} -0.5			V _{CC} -0.4			V
OUTPUT LOAD	TTL			10				TTL
	CMOS			50			30	pF
START-UP TIME	1.0 ~ 30.0 MHz			4			4	ms
	30.1 ~ 80.0 MHz			10			10	ms
ENABLE/DISABLE TIME				100			100	ns

* Inclusive of 25°C tolerance, operating temperature range, input voltage change, load change, aging shock and vibration.

** An internal pullup resistor from pin 1 to 4 allows active output if pin 1 is left open.

PACKAGE DIMENSIONS (mm)

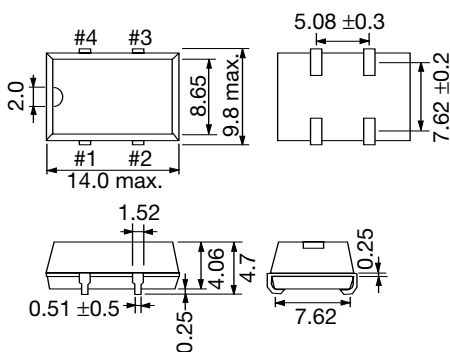

Figure 1) ECS-8F Top and Side view

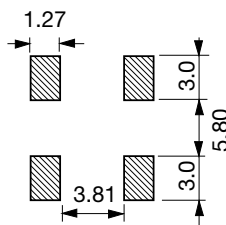
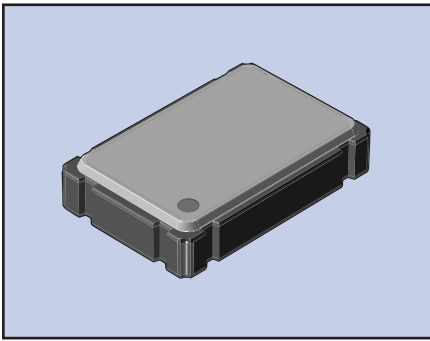

Figure 6) Land Pattern

PIN CONNECTIONS	
#1	TRI-STATE
#2	GND
#3	OUTPUT
#4	V _{CC}

TRI-STATE CONTROL VOLTAGE		
8FM	8FA3	OUTPUT
PIN 1	PIN 1	PIN 3
OPEN**	OPEN**	OSCILLATION
2V MIN	2.4V MIN	OSCILLATION
0.8 MAX	0.6 MAX	HIGH IMPEDANCE



The ECS-3951C (5V) and ECS-3953C (3.3V) Series are miniature, crystal controlled, low current clock oscillator in a ceramic SMD package. The low profile package is ideal for today's advanced portable PC and instrumentation designs.

FEATURES

- 3.3 or 5.0V version
- Miniature profile
- Low power consumption
- Standby function
- Tape & Reel (1,000 pcs)

PART NUMBERING GUIDE

	FREQUENCY (50.0 MHz)	STABILITY TOLERANCE (±50 PPM)
ECS-3951C	- 500	- B

Sample Part Number: ECS-3951C-500-B

OPERATING CONDITIONS/ELECTRICAL CHARACTERISTICS

PARAMETERS	CONDITIONS	ECS-3951C (5V)			ECS-3953C (3.3V)*			UNITS
		MIN	TYP	MAX	MIN	TYP	MAX	
FREQUENCY RANGE		1.800		80.000	1.800		80.000	MHz
TEMPERATURE RANGE	Operating	0		+70	0		+70	°C
	Storage	-55		+125	-55		+125	°C
SUPPLY VOLTAGE		+4.5	+5.0	+5.5	+3.0	+3.3	+3.6	V DC
FREQUENCY STABILITY**	Standard	-100	±40	+100	-100	±40	+100	PPM
	Option (B)	-50		+50	-50		+50	PPM
	Option (C)	-25		+25	-25		+25	PPM
INPUT CURRENT	1.8 ~ 30.0 MHz			10			8	mA
	30.0 ~ 35.0 MHz			15			8	mA
	35.0 ~ 50.0 MHz			30			12	mA
	50.0 ~ 66.0 MHz			30			15	mA
	66.0 ~ 80.0 MHz			50			30	mA
OUTPUT SYMMETRY	@ 1/2 Vcc Level	40/60	50 ±4	60/40	40/60	50 ±4	60/40	%
RISE AND FALL TIMES				10			15	ns
LOGIC "0" LEVEL	Vcc x 0.1V max.							
LOGIC "1" LEVEL	Vcc x 0.9V min.							
LOAD	HCMOS			15			15	pF
START-UP TIME	1.8 ~ 36.0 MHz			5			5	ms
	36.0 ~ 80.0 MHz			10			10	ms
OUTPUT CURRENT (IOL)	VOL=0.5V/0.33			4			4	mA
	VOH=4.5V/2.97V			-4			-4	mA
ENABLE/DISABLE TIME				100			100	ns

* ECS-3953C is also compatible with a supply voltage of +3.0V DC ±0.3V

** Inclusive of 25°C tolerance, operating temperature range, input voltage change, load change, aging shock and vibration.

*** An internal pullup resistor from pin 1 to 4 allows active output if pin 1 is left open.

Note: A 0.01 µF bypass capacitor should be placed between VCC (Pin 4) and GND (Pin 2) to minimize power line noise.

PACKAGE DIMENSIONS (mm)

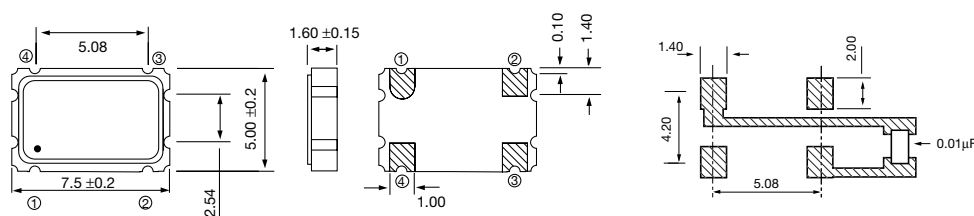
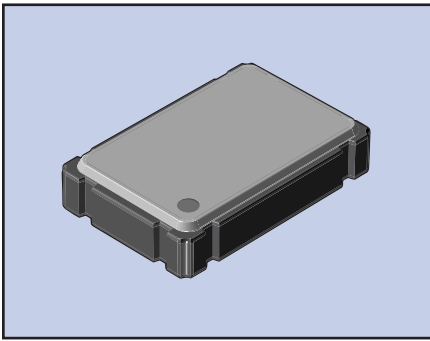

Figure 1) ECS-3951C/3953C Top, Side and Bottom views

Figure 2) Land Pattern

PIN CONNECTIONS	
#1	TRI-STATE***
#2	GND
#3	OUTPUT
#4	VCC

ECS-3951C/3953C Standby Control Voltage	
PIN #1 = OPEN ***	#3 = OSCILLATION
PIN #1 = VCCx0.9 MIN	#3 = OSCILLATION
PIN #1 = VCCx0.1 MAX	#3 = HIGH IMPEDANCE



The ECS-3955C (5V) is high capacitive load version of our miniature, crystal controlled, low current clock oscillator in an all ceramic SMD package. The low profile package is ideal for PC's, portable applications and PCMCIA cards.

FEATURES

- High capacitive load options
- Low power consumption
- Tri-State Function
- Tape & Reel (1,000 pcs STD)

PART NUMBERING GUIDE

	FREQUENCY (50.0 MHz)	STABILITY TOLERANCE (± 50 PPM)
ECS-3955C	500	B

Sample Part Number: ECS-3955C-500-B

OPERATING CONDITIONS/ELECTRICAL CHARACTERISTICS

PARAMETERS	CONDITIONS	ECS-3955C (5V)			UNITS
		MIN	TYP	MAX	
FREQUENCY RANGE		1.800		66.666	MHz
TEMPERATURE RANGE	Operating	0		+70	$^{\circ}$ C
	Storage	-55		+125	$^{\circ}$ C
SUPPLY VOLTAGE		+4.5	+5.0	+5.5	V DC
FREQUENCY STABILITY*	Standard			± 100	PPM
	Option (B)			± 50	PPM
	Option (C)			± 25	PPM
INPUT CURRENT	1.8 ~ 20.0 MHz			20	mA
	20.0 ~ 50.0 MHz			35	mA
	50.1 ~ 66.666 MHz			60	mA
OUTPUT SYMMETRY	@ 1/2 Vcc Level	40/60	50 \pm 4	60/40	%
RISE AND FALL TIMES				10	ns
				Vcc x 0.1V	V DC
OUTPUT VOLTAGE	VOL			Vcc x 0.1V	V DC
	VOH	Vcc x 0.9V			V DC
LOAD	HCMOS			50	pF
START-UP TIME	1.8 ~ 36.0 MHz			5	ms
	36.0 ~ 66.666 MHz			10	ms
OUTPUT CURRENT (IOL) (IOH)	VOL			16	mA
	VOH			-16	mA
ENABLE/DISABLE TIME				100	ns

* Inclusive of 25 $^{\circ}$ C tolerance, operating temperature range, input voltage change, load change, aging shock and vibration.

** An internal pullup resistor from pin 1 to 4 allows active output if pin 1 is left open.

Note: A 0.01 μ F bypass capacitor should be placed between VCC (Pin 4) and GND (Pin 2) to minimize power line noise.

PACKAGE DIMENSIONS (mm)

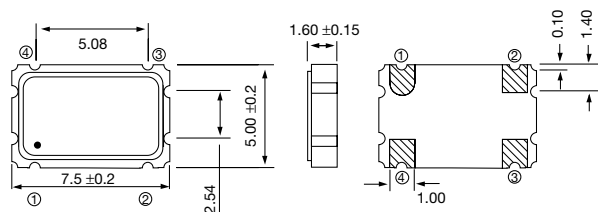

Figure 1) ECS-3955C Top, Side and Bottom views

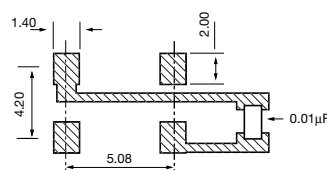
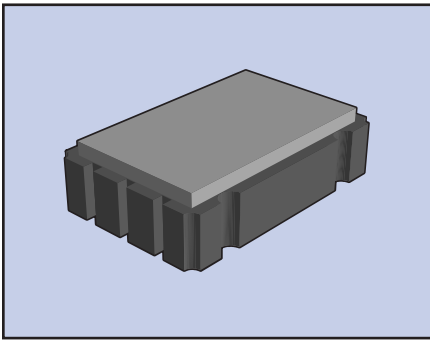

Figure 2) Land Pattern

PIN CONNECTIONS	
#1	TRI-STATE**
#2	GND
#3	OUTPUT
#4	VCC

ECS-3955C Standby Control Voltage	
PIN #1 = OPEN**	#3 = OSCILLATION
PIN #1 = 2.2V MIN	#3 = OSCILLATION
PIN #1 = 0.8V MAX	#3 = HIGH IMPEDANCE



The ECS-3951M (5V) and ECS-3953M (3.3V) Series are miniature, crystal controlled, low current clock oscillators in a ceramic SMD package. Package is seam welded with a metal lid. The low profile package is ideal for today's advanced portable PC and instrumentation designs.

FEATURES

- 3.3 or 5.0V version
- Low power consumption
- Standby function
- Seam welded package
- Tape & Reel (1,000 pcs)

PART NUMBERING GUIDE

	FREQUENCY (50.0 MHz)	STABILITY TOLERANCE (± 50 PPM)
ECS-3951M	- 500	- B

Sample Part Number: ECS-3951M-500-B

OPERATING CONDITIONS/ELECTRICAL CHARACTERISTICS

PARAMETERS	CONDITIONS	ECS-3951M (5V)			ECS-3953M (3.3V)*			UNITS
		MIN	TYP	MAX	MIN	TYP	MAX	
FREQUENCY RANGE		1.800		125.0	1.800		125.00	MHz
TEMPERATURE RANGE	Operating	-10		+70	-10		+70	$^{\circ}$ C
	Storage	-55		+125	-55		+125	$^{\circ}$ C
SUPPLY VOLTAGE		+4.5	+5.0	+5.5	+3.0	+3.3	+3.6	V DC
FREQUENCY STABILITY**	Standard	-100	± 40	+100	-100	± 40	+100	PPM
	Option (B)	-50		+50	-50		+50	PPM
	Option (C)	-25		+25	-25		+25	PPM
INPUT CURRENT	1.8 ~ 36.0 MHz			20			15	mA
	36.0 ~ 70.0 MHz			55			25	mA
	70.0 ~ 100.0 MHz			60			30	mA
	100.0 ~ 125.0 MHz			65			30	mA
OUTPUT SYMMETRY	@ 1/2 Vcc Level	40/60	50 ± 4	60/40	40/60	50 ± 4	60/40	%
RISE AND FALL TIMES	1.8 ~ 70.0 MHz			15			5	nS
	70.0 ~ 125.0 MHz			5			5	nS
LOGIC "0" LEVEL	Vcc x 0.1V max.							
LOGIC "1" LEVEL	Vcc x 0.9V min.							
LOAD	HCMOS			30			15	pF
START-UP TIME	1.8 ~ 36.0 MHz			5			5	ms
	36.0 ~ 70.0 MHz			10			10	ms
	70.0 ~ 100.0 MHz			15			15	ms
OUTPUT CURRENT (IOL)	VOL=0.5V/0.33			4			4	mA
	(IOH) VOL=4.5V/2.97V			-4			-4	mA
ENABLE/DISABLE TIME				100			100	ns

* ECS-3953M is also compatible with a supply voltage of +3.0V DC $\pm 0.3V$

** Inclusive of 25 $^{\circ}$ C tolerance, operating temperature range, input voltage change, load change, aging shock and vibration.

*** An internal pullup resistor from pin 1 to 4 allows active output if pin 1 is left open.

Note: A 0.01 μ F bypass capacitor should be placed between VCC (Pin 4) and GND (Pin 2) to minimize power line noise.

PACKAGE DIMENSIONS (mm)

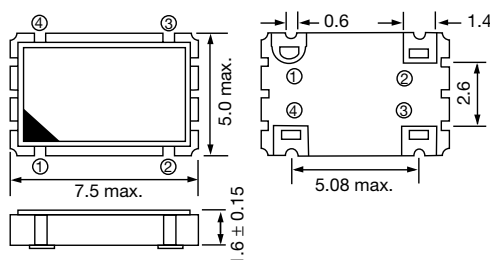

Figure 1) ECS-3951M/3953M Top, Side and Bottom views

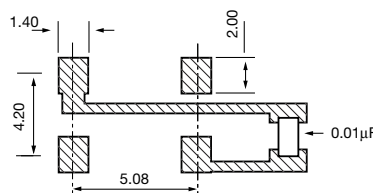
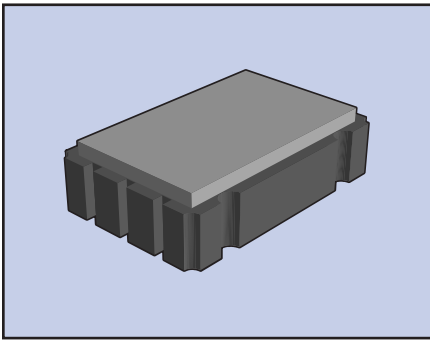

Figure 2) Land Pattern

PIN CONNECTIONS	
#1	TRI-STATE***
#2	GND
#3	OUTPUT
#4	VCC

ECS-3951M/3953M Standby Control Voltage	
PIN #1 = OPEN***	#3 = OSCILLATION
PIN #1 = +2.2V MIN	#3 = OSCILLATION
PIN #1 = 0.8V MAX	#3 = HIGH IMPEDANCE



The ECS-3955M (5V) is a high capacitive load version of our miniature, crystal controlled, low current clock oscillator in an all ceramic SMD package. The low profile package is ideal for PC's, portable applications and PCMCIA cards.

FEATURES

- High capacitive load options
- Low power consumption
- Tri-State Function
- Seam welded package
- Tape & Reel (1,000 pcs STD)

PART NUMBERING GUIDE

	FREQUENCY (50.0 MHz)	STABILITY TOLERANCE (B=±50 PPM)
ECS-3955M	500	B

Sample Part Number: ECS-3955M-500-B

OPERATING CONDITIONS/ELECTRICAL CHARACTERISTICS

PARAMETERS	CONDITIONS	ECS-3955M (5V)			UNITS
		MIN	TYP	MAX	
FREQUENCY RANGE		1.800		70.0	MHz
TEMPERATURE RANGE	Operating	-10		+70	°C
	Storage	-55°		+125	°C
SUPPLY VOLTAGE		+4.5	+5.0	+5.5	V DC
FREQUENCY STABILITY*	Standard			±100	PPM
	Option (B)			±50	PPM
	Option (C)			±25	PPM
INPUT CURRENT	1.8 ~ 36.0 MHz			30	mA
	36.1 ~ 70.0 MHz			65	mA
OUTPUT SYMMETRY	@ 1/2 V _{CC} Level	40/60	50 ±4	60/40	%
RISE AND FALL TIMES				7	ns
OUTPUT VOLTAGE	V _{OL}			V _{CC} x 0.1V	V DC
	V _{OH}	V _{CC} x 0.9V			V DC
LOAD	HCMOS			50	pF
START-UP TIME	1.8 ~ 36.0 MHz			5	ms
	36.0 ~ 70.0 MHz			10	ms
OUTPUT CURRENT (I _{OL}) (I _{OH})	V _{OL}			16	mA
	V _{OH}			-16	mA
ENABLE/DISABLE TIME				100	ns

* Inclusive of 25°C tolerance, operating temperature range, input voltage change, load change, aging shock and vibration.

** An internal pullup resistor from pin 1 to 4 allows active output if pin 1 is left open.

Note: A 0.01 μF bypass capacitor should be placed between VCC (Pin 4) and GND (Pin 2) to minimize power line noise.

PACKAGE DIMENSIONS (mm)

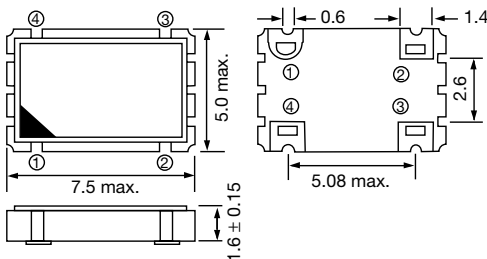

Figure 1) ECS-3955M Series Top, Side and Bottom Views

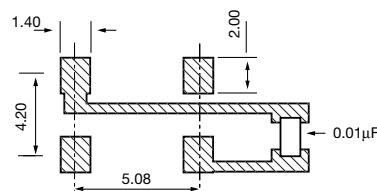
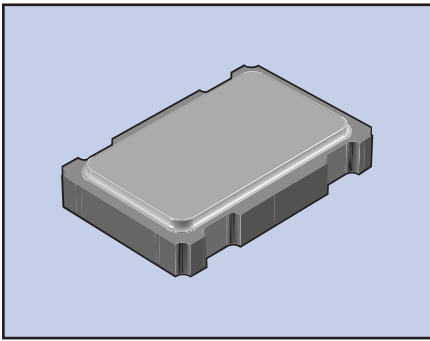

Figure 2) Land Pattern

PIN CONNECTIONS	
#1	TRI-STATE**
#2	GND
#3	OUTPUT
#4	VCC

ECS-3955M Standby Control Voltage	
PIN #1 = OPEN	#3 = OSCILLATION
PIN #1 = +2.2V MIN	#3 = OSCILLATION
PIN #1 = 0.8V MAX	#3 = HIGH IMPEDANCE



The ECS-3961 (5V) and ECS-3963 (3V) is our smallest crystal controlled low-current clock oscillator. This subminiature, very low profile leadless ceramic package is ideal for today's SMD manufacturing environment. Package is seam welded with a metal lid.

FEATURES

- 3x5 mm footprint
- SMD
- 3 & 5V versions
- Seam welded package
- Tape and Reel (1,000 pcs)

PART NUMBERING GUIDE "EXAMPLE"

	SERIES	FREQUENCY (14.4 MHz)	(STABILITY TOLERANCE (A=±100 PPM))
ECS	- 3961	- 144	- A

Sample Part Number: ECS-3961-144-A

OPERATING CONDITIONS/ELECTRICAL CHARACTERISTICS

PARAMETERS	CONDITIONS	ECS-3961 (5V)			ECS-3963 (3.0V)			UNITS
		MIN	TYP	MAX	MIN	TYP	MAX	
FREQUENCY RANGE		2.500		35.000	2.500		66.666	MHz
FREQUENCY STABILITY**	Option (A)	-100		+100	-100		+100	PPM
	Option (B)	-50		+50	-50		+50	PPM
	Option (C)**	-25		+25	-25		+25	PPM
OPERATING TEMPERATURE		-10		+70	-10		+70	°C
STORAGE TEMPERATURE		-55		+125	-55		+125	°C
INPUT VOLTAGE V _{CC}		+4.5	+5	+5.5	+2.7	+3.0	+3.3	V DC
INPUT CURRENT	2.5 ~ 35.0 MHz			15			10	mA
	35.0 ~ 50.0 MHz			-			15	mA
	1.8 ~ 36.0 MHz			-			20	mA
OUTPUT SYMMETRY	@ 1/2 V _{CC} Level	40/60	50 ±4	60/40	40	50 ±4	60	%
RISE AND FALL TIMES				10			10	ns
LOGIC "0" LEVEL	V _{CC} x 0.1V max.							
LOGIC "1" LEVEL	V _{CC} x 0.9V max.							
LOAD				15			15	pF
START-UP				10			10	ms

* Inclusive of 25°C tolerance, operating temperature range, input voltage change, load change, aging shock and vibration.

** Reduced operating temperature with option C (±25 PPM) -10° ~ +60°C

*** An internal pullup resistor from pin 1 to 4 allows active output if pin 1 is left open.

PACKAGE DIMENSIONS (mm)

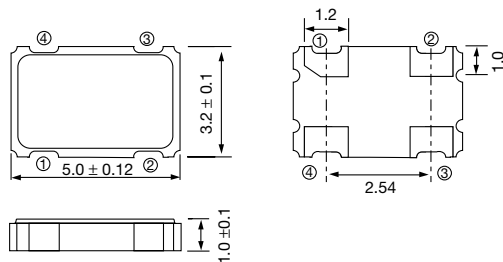

Figure 1) ECS-3961/3963 Series Top, Side and Bottom Views

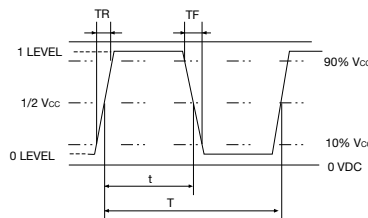

Figure 2) Output Waveform

ECS-3961 (5V) Standby Control Voltage	
PIN #1 = OPEN***	#3 = OUTPUT
PIN #1 = +3.5V MIN	#3 = OUTPUT
PIN #1 = 1.5V MAX	#3 = NO OSCILLATION

ECS-3963 (3V) Standby Control Voltage	
PIN #1 = OPEN***	#3 = OUTPUT
PIN #1 = +2.1V MIN	#3 = OUTPUT
PIN #1 = 0.9V MAX	#3 = NO OSCILLATION

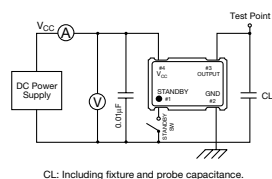

Figure 3) Test Circuit

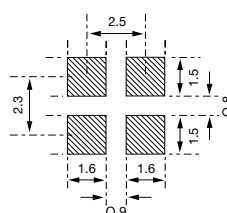

Figure 4) Land Pattern

PIN CONNECTIONS	
#1	TRI-STATE***
#2	GND
#3	OUTPUT
#4	VCC

CUSTOMIZED OPTIONS FOR CLOCK OSCILLATORS

3.3V OPTION
Thru-Hole Oscillators are also available with a Supply Voltage of 3.3V. This change is indicated by adding a "3" suffix to the series portion of the P/N, i.e. ECS-100A with 3.3V = ECS-103A-Freq.

TOLERANCE OVER TEMPERATURE	
CODE	TOLERANCE
A	±100 PPM
B	±50 PPM
C	±25 PPM

OPERATING TEMPERATURE	
CODE	OPERATING TEMPERATURE
L	-10 ~ +70°C
M	-20 ~ +70°C
N	-40 ~ +85°C

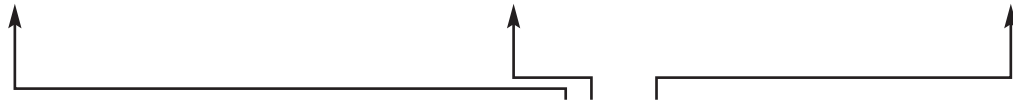

EXAMPLE P/N ECS-103B-250-L

STANDARD CLOCK OSCILLATOR FREQUENCIES																	
FREQUENCY (MHz)	SERIES								FREQUENCY (MHz)	SERIES							
	100	300	400	8FM	2100	2200B	3951	3953		100	300	400	8FM	2100	2200B	3951	3953
1.000	•		•	•	•				16.000	•	•	•	•	•	•	•	
1.2288	•				•				16.257	•				•			
1.8432	•			•	•			•	16.384		•						
2.000	•			•	•				17.734476		•						
2.4576	•		•	•	•				18.000	•				•			
3.579545	•			•	•				18.432	•	•		•	•	•		
3.6864	•			•	•			•	19.6608	•	•		•	•	•		
4.000	•		•	•	•	•			20.000	•	•	•	•	•	•	•	•
4.9152	•			•	•	•			24.000	•	•		•	•	•		•
5.000	•				•				24.576		•						
5.0688	•				•				25.000	•		•	•	•	•		•
6.000	•			•	•	•			25.175	•		•	•	•			
6.144	•				•	•			28.322	•			•	•	•		
7.3728	•			•	•	•			30.000	•	•	•	•	•			
8.000	•		•	•	•	•			32.000	•	•		•	•	•		•
9.216	•				•	•			32.514	•		•	•				
9.8304	•			•	•	•			33.000						•		
10.000	•			•	•	•			35.000	•				•			
11.0592	•			•	•	•			40.000	•			•	•	•	•	•
12.000	•	•		•	•	•	•		48.000	•			•	•	•		
12.288	•	•		•					50.000	•		•	•	•	•	•	•
12.800		•							64.000	•			•				
14.31818	•	•		•	•	•	•		65.000						•		
14.7456	•	•		•	•				66.666	•		•	•	•	•	•	•
15.9744		•							80.000					•			•

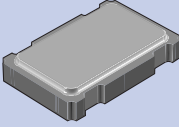
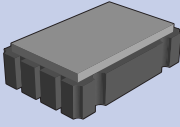
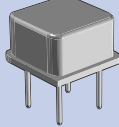
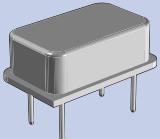
PRODUCT	ECS-P53/55	ECS-P73/P75	ECS-P83/P85	ECS-P143-145
PRODUCT ILLUSTRATION				
FREQUENCY RANGE	1.0 ~ 125 MHz	1.0 ~ 150 MHz	1.0 MHz ~ 150 MHz	1.0 ~ 150 MHz
FREQUENCY STABILITY	±100 PPM	±100 PPM	±100 PPM	±100 PPM
TEMPERATURE RANGE	-10 ~ +70°C	0 ~ +70°C	0 ~ +70°C	0 ~ +70°C
FEATURES	<ul style="list-style-type: none"> • Programmable (2 Time) • Extended Temp Range • 3.2 x 5 Footprint 	<ul style="list-style-type: none"> • Programmable (2 Time) • Extended Temp Range • 5 x 7 Footprint 	<ul style="list-style-type: none"> • Programmable (2 Time) • Extended Temp Range • 8 Pin Dip 	<ul style="list-style-type: none"> • Programmable (2 Time) • Extended Temp Range • 14 Pin Dip
PAGE #	49	50	51	52

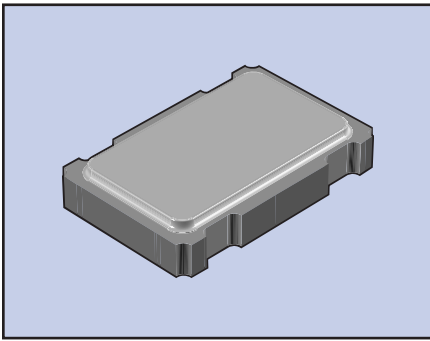

The ECS-P53 (3.3V) and ECS-P55 (5V) is our smallest programmable crystal controlled oscillator. This sub-miniature, very low profile package is ideal for today's SMD manufacturing environment.

FEATURES

- Programmable (2 time)
- 3.3V & 5V options
- PLL technology
- Extended temp range
- 3.2 x 5 mm footage

PART NUMBERING GUIDE "EXAMPLE"

PART NUMBER	SERIES	FREQUENCY (MHz)	STABILITY	EXTENDED TEMP (OPTION)
ECS	P53	- 16.312 -	A	- N

Sample Part Number: ECS-P53-16.312-AN

OPERATING CONDITIONS/ELECTRICAL CHARACTERISTICS

PARAMETERS	CONDITIONS	ECS-P53 (3.3V)			ECS-P55 (5V)			UNITS
		MIN	TYP	MAX	MIN	TYP	MAX	
FREQUENCY RANGE		1.000		125.000	1.000		125.000	MHz
FREQUENCY STABILITY*	Option A			±100			±100	PPM
	Option B			±50			±50	PPM
OPERATING TEMPERATURE	Standard	-10		+70	-10		+70	°C
	Extended (Option N)	-40		+85	-40		+85	°C
STORAGE TEMPERATURE		-55		+125	-55		+125	°C
INPUT VOLTAGE (Vcc)		+3.0	+3.3	+3.6	+4.5	+5.0	+5.5	VDC
INPUT CURRENT	1.0 ~ 40.0 MHz			15			25	mA
	40.1 ~ 70.0 MHz			22			40	mA
	0.1 ~ 125.0 MHz			30			50	mA
OUTPUT SYMMETRY at 1/2 Vcc Level	1.0 ~ 70.0 MHz	45/55		55/45	45/55		55/45	%
	70.1 ~ 125.0 MHz	40/60		60/40	40/60		60/40	%
RISE AND FALL TIMES	20% Vcc to 80% Vcc			4			4	ns
JITTER	1.0 ~ 33.0 MHz			250			250	pS p-p
	33.1 ~ 125.0 MHz			250			200	pS p-p
"0" LEVEL				Vcc x 0.1			Vcc x 0.1	VDC
"1" LEVEL		Vcc x 0.9			Vcc x 0.9			VDC
LOAD				15			15	pF
ENABLE/DISABLE TIME				150			100	ns
START-UP TIME				10			10	ms

* Inclusive of 25°C tolerance, operating temperature range, input voltage change, load change aging, shock and vibration.

PACKAGE DIMENSIONS (mm)

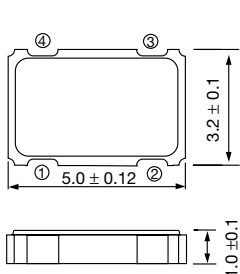

Figure 1) Top, Bottom and Side views

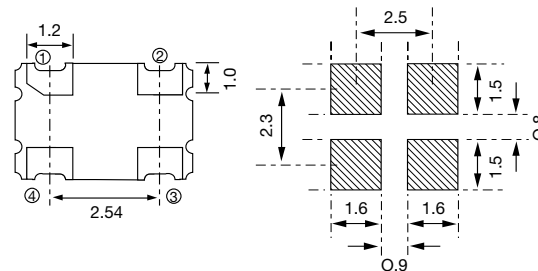
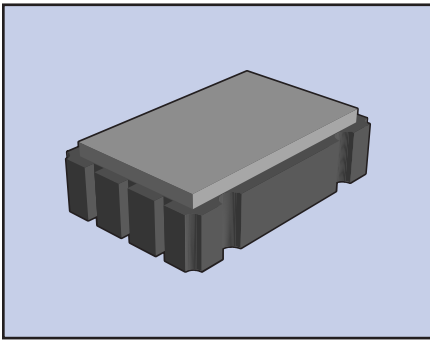

Figure 2) Land Pattern

ECS-P53 (3.3 V) TRI-STATE CONTROL VOLTAGE	
PIN #1 = OPEN	#3 = OUTPUT
PIN #1 = +0.7V MIN	#3 = OUTPUT
PIN #1 = +0.2V MAX	#3 = HIGH IMPEDANCE

ECS-P55 (5 V) TRI-STATE CONTROL VOLTAGE	
PIN #1 = OPEN	#3 = OUTPUT
PIN #1 = +2.0V MIN	#3 = OUTPUT
PIN #1 = +0.8V MAX	#3 = HIGH IMPEDANCE

PIN CONNECTIONS	
#1	TRI-STATE
#2	GND
#3	OUTPUT
#4	VCC



The ECS-P73 (3.3V) and ECS-P75 (5V) is our miniature, twice programmable crystal controlled oscillator. This miniature, very low profile leadless ceramic package is ideal for today's SMD manufacturing environment.

FEATURES

- Programmable (2 time)
- 3.3V & 5V options
- PLL technology
- Extended temp range
- 5 x 7.5 mm footage

PART NUMBERING GUIDE "EXAMPLE"

PART NUMBER	SERIES	FREQUENCY (MHz)	STABILITY	EXTENDED TEMP (OPTION)
ECS	P73	- 16.312 -	A	- N

Sample Part Number: ECS-P73-16.312-AN

OPERATING CONDITIONS/ELECTRICAL CHARACTERISTICS

PARAMETERS	CONDITIONS	ECS-P73 (3.3V)			ECS-P75 (5V)			UNITS
		MIN	TYP	MAX	MIN	TYP	MAX	
FREQUENCY RANGE		1.000		125.000	1.000		150.000	MHz
FREQUENCY STABILITY*	Option A			±100			±100	PPM
	Option B			±50			±50	PPM
OPERATING TEMPERATURE	Standard	0		+70	0		+70	°C
	Extended (Option N)	-40		+85	-40		+85	°C
STORAGE TEMPERATURE		-55		+125	-55		+125	°C
INPUT VOLTAGE (Vcc)		+2.97	+3.3	+3.63	+4.5	+5.0	+5.5	VDC
INPUT CURRENT				28			45	mA
OUTPUT SYMMETRY	at 1/2 Vcc LEVEL	40/60		60/40	40/60		60/40	%
RISE AND FALL TIMES	20% Vcc to 80% Vcc			4			4	ns
JITTER	1.0 ~ 33.0 MHz		±100	±250	±100		±250	pS
	> 33.1 MHz		±50	±100	±50		±100	pS
"0" LEVEL				0.4			0.4	VDC
"1" LEVEL		2.7			Vcc - 0.5			VDC
LOAD (HCMOS)	1.0 ~ 50.0 MHz			30			50	pF
	> 50.1 MHz			15			15	pF
ENABLE/DISABLE TIME				150			100	ns
START-UP TIME				10			10	ms

* Inclusive of 25°C tolerance, operating temperature range, input voltage change, load change aging, shock and vibration.

PACKAGE DIMENSIONS (mm)

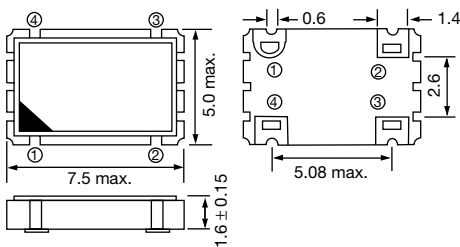

Figure 1) Top, Side, and Bottom views

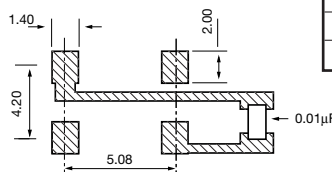

Figure 2) Land Pattern

ECS-P73 (3.3V) TRI-STATE CONTROL VOLTAGE

PIN #1 = OPEN	#3 = OUTPUT
PIN #1 = +0.7V MIN	#3 = OUTPUT
PIN #1 = +0.2V MAX	#3 = HIGH IMPEDANCE

ECS-P75 (5V) TRI-STATE CONTROL VOLTAGE

PIN #1 = OPEN	#3 = OUTPUT
PIN #1 = +2.0V MIN	#3 = OUTPUT
PIN #1 = +0.8V MAX	#3 = HIGH IMPEDANCE

PIN CONNECTIONS

#1	TRI-STATE**
#2	GND
#3	OUTPUT
#4	VCC

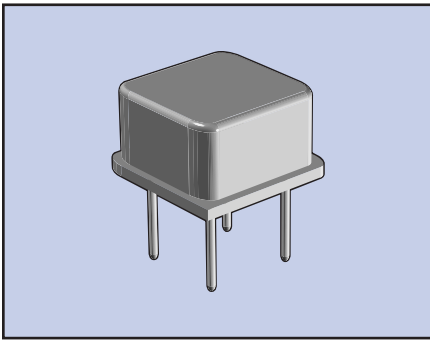

The ECS-P83 (3.3V) and ECS-P85 (5V) 8 pin dip DIP is a twice programmable crystal controlled oscillator. The standard 8 pin DIP footprint is ideal for existing PC boards.

FEATURES

- Programmable (2 time)
- 3.3V & 5V options
- PLL technology
- 8 pin DIP footprint
- Extended temp range

PART NUMBERING GUIDE "EXAMPLE"

PART NUMBER	SERIES	FREQUENCY (MHz)	STABILITY	EXTENDED TEMP (OPTION)
ECS	P83	- 16.312 -	A	- N

Sample Part Number: ECS-P83-16.312-AN

OPERATING CONDITIONS/ELECTRICAL CHARACTERISTICS

PARAMETERS	CONDITIONS	ECS-P83 (3.3V)			ECS-P85 (5V)			UNITS
		MIN	TYP	MAX	MIN	TYP	MAX	
FREQUENCY RANGE		1.000		125.000	1.000		150.000	MHz
FREQUENCY STABILITY*	Option A			±100			±100	PPM
	Option B			±50			±50	PPM
OPERATING TEMPERATURE	Standard	0		+70	0		+70	°C
	Extended (Option N)	-40		+85	-40		+85	°C
STORAGE TEMPERATURE		-55		+125	-55		+125	°C
INPUT VOLTAGE (Vcc)		+2.97	+3.3	+3.63	+4.5	+5.0	+5.5	VDC
INPUT CURRENT				28			45	mA
OUTPUT SYMMETRY	at 1/2 Vcc LEVEL	40/60		60/40	40/60		60/40	%
RISE AND FALL TIMES	20% Vcc to 80% Vcc			4			4	ns
JITTER	1.0 ~ 33.0 MHz		±100	±250	±100		±250	pS
	> 33.1 MHz		±50	±100	±50		±100	pS
"0" LEVEL				0.4			0.4	VDC
"1" LEVEL		2.7			Vcc - 0.5			VDC
LOAD (HCMOS)	1.0 ~ 50.0 MHz			30			50	pF
	> 50.1 MHz			15			15	pF
ENABLE/DISABLE TIME				150			100	ns
START-UP TIME				10			10	ms

* Inclusive of 25°C tolerance, operating temperature range, input voltage change, load change aging, shock and vibration.

PACKAGE DIMENSIONS (mm)

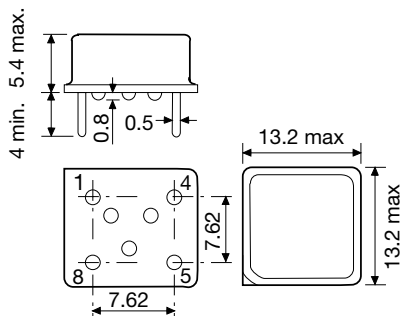
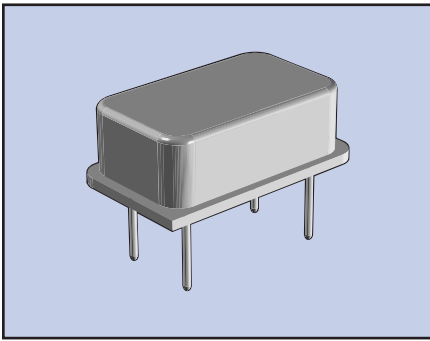

Figure 1) Side, Bottom and Top views

ECS-P83 (3.3V) TRI-STATE CONTROL VOLTAGE	
PIN #1 = OPEN	#3 = OUTPUT
PIN #1 = +0.7V MIN	#3 = OUTPUT
PIN #1 = +0.2V MAX	#3 = HIGH IMPEDANCE

ECS-P85 (5V) TRI-STATE CONTROL VOLTAGE	
PIN #1 = OPEN	#3 = OUTPUT
PIN #1 = +2.0V MIN	#3 = OUTPUT
PIN #1 = +0.8V MAX	#3 = HIGH IMPEDANCE

PIN CONNECTIONS	
#1	TRI-STATE
#4	GND
#5	OUTPUT
#8	VCC



The ECS-P143 (3.3V) and ECS-P145 (5V) 14 pin dip DIP is a twice programmable crystal controlled oscillator. The standard 14 pin DIP footprint is ideal for existing PC boards.

FEATURES

- Programmable (2 time)
- 3.3V & 5V options
- PLL technology
- 14 pin DIP footprint
- Extended temp range

PART NUMBERING GUIDE *"EXAMPLE"*

PART NUMBER	SERIES	FREQUENCY (MHz)	STABILITY	EXTENDED TEMP (OPTION)
ECS	P143	- 16.312 -	A	- N

Sample Part Number: ECS-P143-16.312-AN

OPERATING CONDITIONS/ELECTRICAL CHARACTERISTICS

PARAMETERS	CONDITIONS	ECS-P143 (3.3V)			ECS-P145 (5V)			UNITS
		MIN	TYP	MAX	MIN	TYP	MAX	
FREQUENCY RANGE		1.000		125.000	1.000		150.000	MHz
FREQUENCY STABILITY*	Option A			±100			±100	PPM
	Option B			±50			±50	PPM
OPERATING TEMPERATURE	Standard	0		+70	0		+70	°C
	Extended (Option N)	-40		+85	-40		+85	°C
STORAGE TEMPERATURE		-55		+125	-55		+125	°C
INPUT VOLTAGE (Vcc)		+2.97	+3.3	+3.63	+4.5	+5.0	+5.5	VDC
INPUT CURRENT				28			45	mA
OUTPUT SYMMETRY	at 1/2 Vcc LEVEL	40/60		60/40	40/60		60/40	%
RISE AND FALL TIMES	20% Vcc to 80% Vcc			4			4	ns
JITTER	1.0 ~ 33.0 MHz		±100	±250	±100		±250	pS
	> 33.1 MHz		±50	±100	±50		±100	pS
"0" LEVEL				0.4			0.4	VDC
"1" LEVEL		2.7			Vcc - 0.5			VDC
LOAD (HCMOS)	1.0 ~ 50.0 MHz			30			50	pF
	> 50.1 MHz			15			15	pF
ENABLE/DISABLE TIME				150			100	ns
START-UP TIME				10			10	ms

* Inclusive of 25°C tolerance, operating temperature range, input voltage change, load change aging, shock and vibration.

PACKAGE DIMENSIONS (mm)

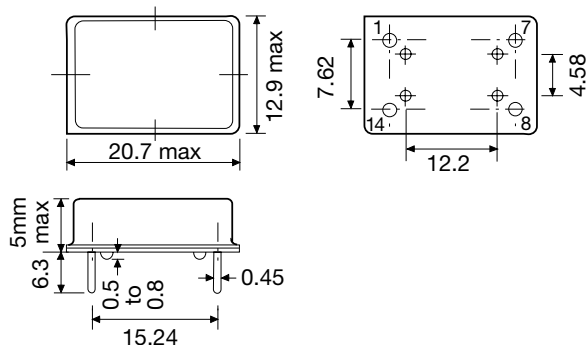
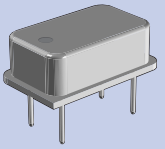
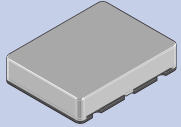
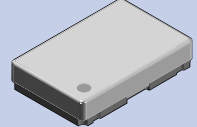
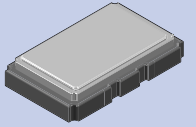

Figure 1) Top, Bottom and Side views

ECS-P143 (3.3V) TRI-STATE CONTROL VOLTAGE	
PIN #1 = OPEN	#3 = OUTPUT
PIN #1 = +0.7V MIN	#3 = OUTPUT
PIN #1 = +0.2V MAX	#3 = HIGH IMPEDANCE

ECS-P145 (5V) TRI-STATE CONTROL VOLTAGE	
PIN #1 = OPEN	#3 = OUTPUT
PIN #1 = +2.0V MIN	#3 = OUTPUT
PIN #1 = +0.8V MAX	#3 = HIGH IMPEDANCE

PIN CONNECTIONS	
#1	TRI-STATE
#7	GND
#8	OUTPUT
#14	VCC

PRODUCT	ECS-500 SERIES TXO	ECS-TXO-39SM	VC-TXO-30SM	VC-TXO-35SM
PRODUCT ILLUSTRATION				
FREQUENCY RANGE	8.0 ~ 80 MHz	10.0 ~ 19.44 MHz	9.6 ~ 26 MHz	12.0 ~ 26 MHz
FREQUENCY STABILITY	±7 PPM	±2.5 PPM	±2.5 PPM	±2.5 PPM
TEMPERATURE RANGE	-20 ~ +70°C	-30 ~ +75°C	-30 ~ +75°C	-30 ~ +75°C
FEATURES	<ul style="list-style-type: none"> • TTL/CMOS • ±3.5 & 5 PPM Options • Wide Frequency Range • 14 Pin DIP Package 	<ul style="list-style-type: none"> • Low Profile VC-TCXO • Low Voltage Feature • SMD Package 	<ul style="list-style-type: none"> • SMD VC-TCXO • 2.0 mm Low Profile • VCTCXO Optional • 5 x 7 Footprint 	<ul style="list-style-type: none"> • 1.8 mm Profile TCXO • SMD VC-TCXO • 3.2 x 5 Footprint
PAGE #	54	55	56	57

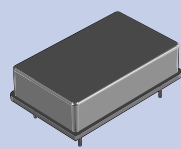
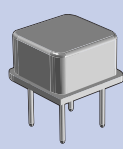
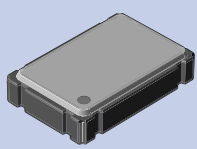
PRODUCT	ECS-VXO-11	ECS-VXO-143/VXO-83	ECS-VXO-73/VXO-75 ECS-VXO-97
PRODUCT ILLUSTRATION			
FREQUENCY RANGE	12 ~ 100 MHz	8.0 ~ 40.0 MHz	12.0 ~ 77.760 MHz
FREQUENCY STABILITY	±25 PPM	±25 PPM	±50 PPM
TEMPERATURE RANGE	0 ~ +70°C	0 ~ +70°C	-10 ~ +70°C
FEATURES	<ul style="list-style-type: none"> • VCXO • HCMOS/TTL Output • Wide Frequency Range • 14 Pin DIP Package 	<ul style="list-style-type: none"> • 3.3V VCXO • Voltage Control Options ±50, ±100 & ±150 PPM • Full size & Half size Package 	<ul style="list-style-type: none"> • VCXO • Voltage Control ±100 PPM • SMD 5 x 7 Footprint
PAGE #	58	59	60-61

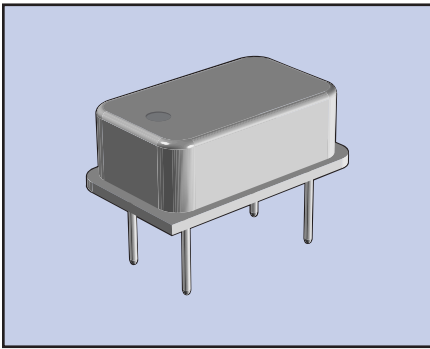

The ECS-500 temperature compensated oscillator covers a wide frequency range and offers a highly stable output over temperature. An internal trimmer is a standard feature to tune the TCXO to its nominal frequency.

FEATURES

- Highly stable output over temperature
- Wide frequency range
- Industry standard DIP 14 pin lead spacing
- TTL/CMOS Compatible

PART NUMBERING GUIDE “EXAMPLE”

	SERIES	FREQUENCY (14.4 MHz)	FREQUENCY STABILITY (B=± 5.0 PPM)
ECS	- 500	- 144	- B

OPERATING CONDITIONS/ELECTRICAL CHARACTERISTICS

PARAMETERS	CONDITIONS	MINIMUM	TYPICAL	MAXIMUM	UNITS
FREQUENCY RANGE		8.000		80.000	MHz
FREQUENCY STABILITY	Option A	-7.0		+7.0	PPM
	Option B	-5.0		+5.0	PPM
	Option C	-3.5		+3.5	PPM
OPERATING TEMPERATURE		-20		+70	°C
STORAGE TEMPERATURE		-30		+80	°C
INPUT VOLTAGE (V _{CC})		4.5 V	5.0 V	5.5 V	V DC
INPUT CURRENT	8.0 TO 30.0 MHz			15	mA
	30.0 TO 80.0 MHz			60	mA
SYMMETRY	at 1.4 VDC Level	40/60	50 ±4	60/40	%
	at 1/2 V _{CC} Level	45/55	50 ±2	55/45	%
RISE TIME	8.0 TO 30.0 MHz			13	ns
	30.0 TO 80.0 MHz			8	ns
FALL TIME	8.0 TO 30.0 MHz			11	ns
	30.0 TO 80.0 MHz			6	ns
“0” LEVEL	TTL			+0.4	V
	CMOS			+0.5	V
“1” LEVEL	TTL	+2.4			V
	CMOS	V _{CC} -0.5			V
OUTPUT LOAD	TTL			10	TTL gates
	CMOS			15	pF
START-UP TIME	8.0 TO 30.0 MHz			10	ns
	30.0 TO 80.0 MHz			7	ns
FREQUENCY ADJUSTMENT	Internal Trimmer	±5			PPM

PACKAGE DIMENSIONS (mm)

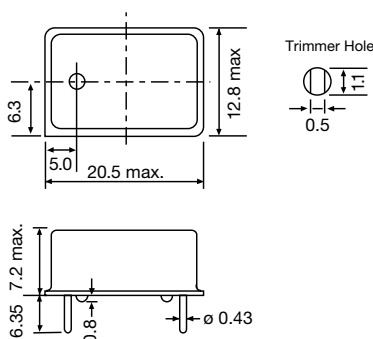

Figure 1) ECS-500 – Top, Side and Bottom views

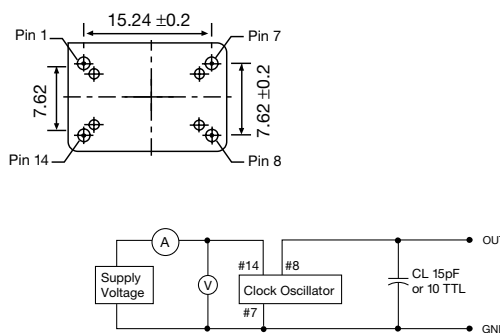

Figure 2) Test Circuit

PIN CONNECTIONS	
#1	N.C.
#7	GND
#8	OUTPUT
#14	+VCC

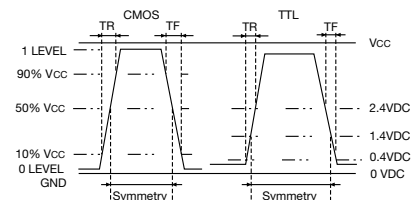
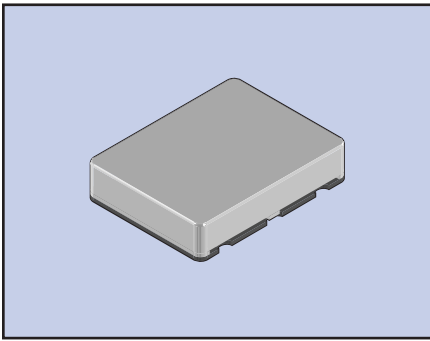

Figure 3) Output Waveform



The VC-TXO-39SM is a VC (Voltage Controlled) TCXO (Temperature Compensated Crystal Oscillator) featuring very tight stability over a wide temperature range. The small SMD ceramic package measures 11.4 x 9.6 x 2.3 mm. The voltage control has a tuning range of ± 12 ppm typical. The low profile package is ideal for wireless communications applications.

FEATURES

- Highly stable output
- Wide temperature range
- Voltage control function
- Tape and Reel (500 pcs)

PART NUMBERING GUIDE

SERIES	FREQUENCY	STABILITY / TEMPERATURE OPTION
VC-TXO-39SM	- 128	- A

Sample Part Number: VC-TXO-39SM-128-A, 128=12.8 MHz, A= ± 1.5 ppm -20 to +75°C

STANDARD FREQUENCIES

10.000, 13.000, 16.800 AND 19.440 MHz

OPERATING CONDITIONS/ELECTRICAL CHARACTERISTICS

PARAMETERS	CONDITIONS	ECS-3955C (5V)			UNITS
		MIN	TYP	MAX	
FREQUENCY RANGE		10.000		19.440	MHz
FREQUENCY STABILITY/TEMP	Operating Temperature				
STANDARD	-30 ~ +75°C			± 2.5	PPM
OPTION A	-20 ~ +75°C			+1.5	PPM
SUPPLY VOLTAGE CHANGE	+3V $\pm 5\%$			+0.3	PPM
LOAD CHANGE	10k Ω $\pm 10\%$ / 10pF $\pm 10\%$			+0.3	PPM
AGING	First Year @ +25°C			± 1	PPM
STORAGE TEMPERATURE		-40		+85	°C
SUPPLY VOLTAGE	+3.0 V DC Nominal	+2.85	+3.0	+3.15	V DC
CURRENT CONSUMPTION	10k Ω $\pm 10\%$ / 10pF $\pm 10\%$			1.5	mA
OUTPUT VOLTAGE	Clipped sine wave (DC-Cut)	0.8			Vp-p
OUTPUT LOAD	10k Ω $\pm 10\%$ / 10pF $\pm 10\%$				
FREQUENCY CONTROL RANGE	+1.5 V DC ± 1 V Positive Slope	± 9	± 12		PPM
CONTROL VOLTAGE		+0.5	+1.5	+2.5	V

PACKAGE DIMENSIONS (mm)

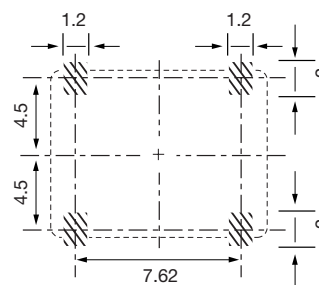
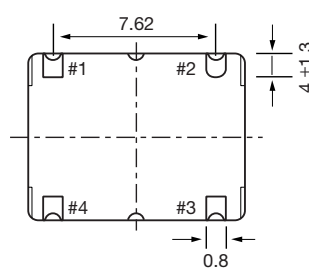
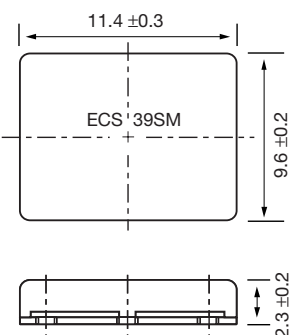

PIN CONNECTIONS	
#1	VCONTROL
#2	GND
#3	OUTPUT
#4	VCC

Figure 1) VC-TXO-36SM Top, Side and Bottom views

Figure 2) Land Pattern

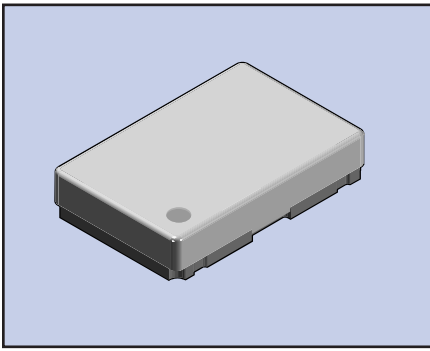

The VC-TXO-30SM is a TCXO (Temperature Compensated Crystal Oscillator) featuring very tight stability over a wide temperature range. The miniature SMD ceramic package measures 5 x 7 x 2.0 mm. The voltage control feature has a frequency control range of ± 5 ppm. The low profile package is ideal for wireless communications applications.

FEATURES

- Highly stable output
- Voltage Control function
- 5 x 7 mm Footprint
- Tape and Reel

PART NUMBERING GUIDE "EXAMPLE"

SERIES	FREQUENCY	STABILITY/TEMPERATURE OPTION
VC-TXO-30SM	- 128	- B

Sample Part Number: VC-TXO-30SM-128-B, 128=12.8 MHz, B= ± 2.0 PPM -20 +75°C

STANDARD FREQUENCIES
12.60, 12.80, 13.00, 14.40, 14.85, 16.80
19.20, 19.44, 19.68 & 19.80 MHz

OPERATING CONDITIONS/ELECTRICAL CHARACTERISTICS

PARAMETERS	CONDITIONS	VC-TXO-30SM		UNITS
		MIN	MAX	
FREQUENCY RANGE		12.600	19.800	MHz
FREQUENCY TOLERANCE	TYPICAL @+25° $\pm 2^\circ\text{C}$	-0.5	+0.5	PPM
FREQ. STABILITY/TEMP.	(OPTION A) OPER. TEMP. -10 ~ +60°C	-2.0	+2.0	PPM
	(OPTION B) OPER. TEMP. -20 ~ +75°C	-2.0	+2.0	PPM
	(OPTION C) OPER. TEMP. -20 ~ +75°C	-2.5	+2.5	PPM
	(OPTION D) OPER. TEMP. -30 ~ +80°C	-2.5	+2.5	PPM
SUPPLY VOLTAGE CHANGE	+3V $\pm 5\%$	-0.2	+0.2	PPM
LOAD CHANGE	10K Ω $\pm 10\%$ /10 pF $\pm 10\%$	-0.3	+0.3	PPM
AGING	First Year @ +25°C	-1.0	+1.0	PPM
STORAGE TEMPERATURE		-40	+85	°C
SUPPLY VOLTAGE	+3.0V DC Nominal	+2.85	+3.15	V DC
CURRENT CONSUMPTION	10K Ω $\pm 10\%$ /10 pF $\pm 10\%$		2.0	mA
OUTPUT VOLTAGE	Clipped Sine Wave (DC-Cut)	0.8		Vp-p
OUTPUT LOAD	10K Ω $\pm 10\%$ /10 pF $\pm 10\%$			
FREQUENCY CONTROL		± 5.0		PPM
CONTROL VOLTAGE	+1.5 VDC ± 1 V Positive Slope	0.5	2.5	V
SSB PHASE NOISE	-120 dBc/Hz @ 1 KHz offset			
HARMONIC DISTORTION			-3.0	dBc

Ultrasonic or Dip cleaning not to be used

Preliminary outline drawing. Consult factory for latest revision. (Rev. 1/03).

PACKAGE DIMENSIONS (mm)

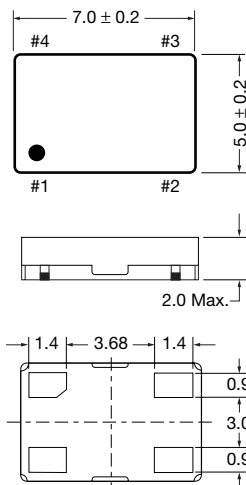

Figure 1) VC-TXO-30SM – Top, Side and Bottom views

VC-TXO-30SM PIN CONNECTIONS	
#1	V CONTROL
#2	GND
#3	OUTPUT
#4	Vcc

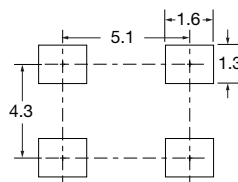
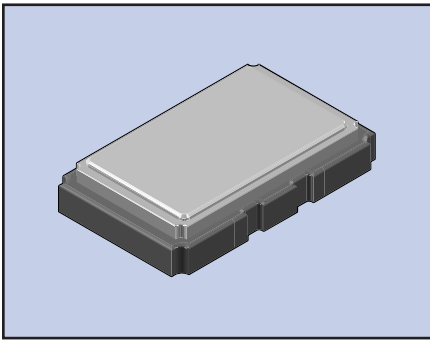

Figure 2) Land Pattern



The VC-TXO-35SM is a VC (Voltage Controlled) TCXO (Temperature Compensated Crystal Oscillator) featuring very tight stability over a wide temperature range. The small subminiature SMD ceramic package measures 3.2 x 5.0 x 1.5 mm. The voltage control has a tuning range of ± 5 ppm minimum. The low profile package is ideal for wireless communications applications.

FEATURES

- Highly stable output
- Wide temperature
- Voltage control function
- Small footprint
- Tape and Reel (1,000 pcs.)

PART NUMBERING GUIDE

SERIES	FREQUENCY	STABILITY / TEMPERATURE OPTION
VC-TXO-35SM	- 128	- B

Sample Part Number: VC-TXO35SM-128-B, 128=12.8 MHz, B= ± 2.5 ppm -30 to +75°C

STANDARD FREQUENCIES

13.000, 14.400, 16.800 AND 19.440 MHz

OPERATING CONDITIONS/ELECTRICAL CHARACTERISTICS

PARAMETERS	CONDITIONS	VC-TXO-35SM (5V)			UNITS
		MIN	TYP	MAX	
FREQUENCY RANGE		12.000		26.000	MHz
FREQUENCY STABILITY/TEMP	(OPTION A) OPER. TEMP. -20 ~ +75°C			± 1.5	PPM
	(OPTION B) OPER. TEMP. -30 ~ +75°C			± 2.5	PPM
	(OPTION C) OPER. TEMP. -20 ~ +75°C			± 2.5	PPM
	(OPTION D) OPER. TEMP. -30 ~ +80°C			± 2.5	PPM
SUPPLY VOLTAGE CHANGE	+3.0 V $\pm 5\%$			± 0.3	PPM
LOAD CHANGE	10k Ω $\pm 10\%$ / 10pF $\pm 10\%$			± 0.2	PPM
AGING	Per Year @ +25°C ± 3 °C			± 1	PPM
STORAGE TEMPERATURE		-40		+85	°C
SUPPLY VOLTAGE	+3.0 V DC Nominal	+2.85	+3.0	+3.15	V DC
INPUT CURRENT	Without Load			1.5	mA
OUTPUT VOLTAGE	Clipped sine wave (DC-Cut)	0.8			Vp-p
OUTPUT LOAD	10k Ω $\pm 10\%$ / 10pF $\pm 10\%$				
FREQUENCY CONTROL RANGE	+1.5 V DC ± 1 V Positive Slope	± 9		± 15	PPM
CONTROL VOLTAGE		+0.5	+1.5	+2.5	V

PACKAGE DIMENSIONS (mm)

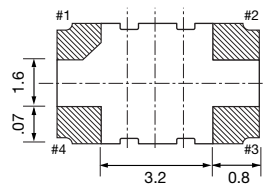
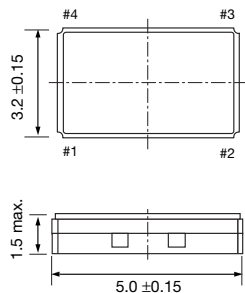

PAD CONNECTIONS	
#1	VCONTROL
#2	GND
#3	OUTPUT
#4	VCC

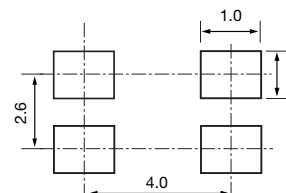
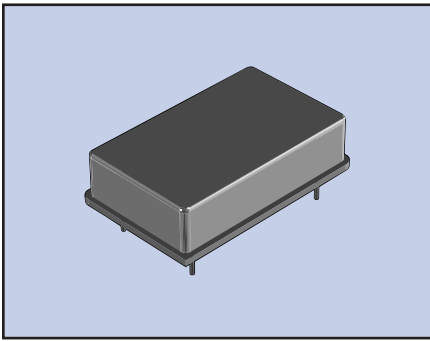

Figure 1) VC-TXO-35SM Top, Side and Bottom views

Figure 2) Land Pattern



The ECS-VXO-11 Series is a wide frequency, tight tolerance, voltage controlled crystal oscillator. Featuring a wide VCO range of ± 200 ppm, this oscillator is a serious performer in applications such as wireless communications, video data compression or PLL.

FEATURES

- Wide voltage control range
- Wave form symmetry of 40/60%
- HCMOS or TTL output
- Industry standard DIP 14 pin lead spacing

PART NUMBERING GUIDE "EXAMPLE"

ECS-VXO-11	FREQUENCY STABILITY ①	TTL OUTPUT LOGIC ②	VOLTAGE CONTROL RANGE ③	FREQUENCY (40.000MHz)
ECS-VXO-11	- B -	TT -	2 -	400

Example - ± 50 PPM Stability, TTL Logic, ± 100 PPM Voltage Control Range, 40 MHz.

OPERATING CONDITIONS/ELECTRICAL CHARACTERISTICS

PARAMETERS	CONDITIONS	SPECIFICATIONS	UNIT
FREQUENCY RANGE	ALL	12.000 - 100.000	MHz
FREQUENCY STABILITY ①	0 ~ +70°C	± 25 (A)	PPM
		± 50 (B)	PPM
OUTPUT LOGIC ②	TTL type	2 (TT)	TTL
	HCMOS type	15 (HC)	pF
VOLTAGE CONTROL RANGE ③	12.0MHz ~ 45MHz	$\pm 50(1)$, $\pm 100(2)$, $\pm 150(3)$, $\pm 200(4)$, Custom(0)	PPM
	45.1MHz ~ 100MHz	$\pm 50(1)$, Custom(0)	PPM
RISE AND FALL TIME	12.0MHz ~ 45MHz	8 max.	nsec.
	45.1MHz ~ 100MHz	5 max.	nsec.
OUTPUT VOLTAGE	V_{OH}	2.4 min. / V_{DD} - 0.5 min.	V
	V_{OL}	0.4 max.	V
CURRENT CONSUMPTION	12.0MHz ~ 45MHz	50 max.	mA
	45.1MHz ~ 100MHz	70 max.	mA
VOLTAGE CONTROL	ALL	2.5 ± 2.0	V
AGING @ +25°C	Per Year	± 1.0	PPM
SUPPLY VOLTAGE	ALL	$5.0 \pm 5\%$	VDC
STORAGE TEMPERATURE	ALL	-55 ~ +125	°C

PACKAGE DIMENSIONS (mm)

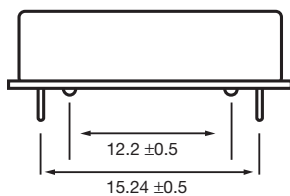
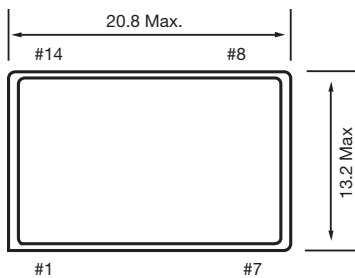

ECS-VXO-11 Series - Top and Side views

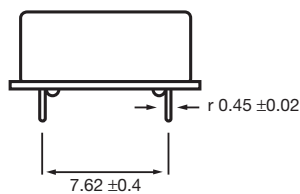

PIN CONNECTIONS	
#1	VC
#7	GND/CASE
#8	OUTPUT
#14	+Vcc

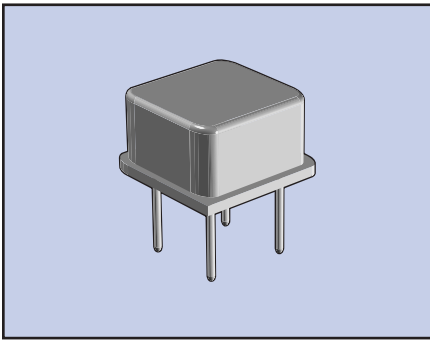

The ECS-VXO-143 (Full Size) and ECS-VXO-83 (Half Size) 3.3V Voltage Controlled Crystal Oscillator offers a wide range of pull ranges from ± 50 ppm to ± 150 ppm. The ECS-VXO-83 is available with a gull wing option for surface mount applications.

FEATURES

- 3.3V supply voltage
- Wide pull range
- Gull wing option

PART NUMBERING GUIDE "EXAMPLE"

PACKAGE TYPE*	FREQUENCY STABILITY	FREQUENCY CONTROL	FREQUENCY (27 MHz)
ECS-VXO-83	- A -	2	270

*Package Type options ECS-VXO-143 = Full Size (Figure 1), ECS-VXO-83 = Half Size (Figure 2)

OPERATING CONDITIONS/ELECTRICAL CHARACTERISTICS

PARAMETERS	CONDITIONS	MINIMUM	TYPICAL	MAXIMUM	UNITS
FREQUENCY RANGE		1.000		52.000	MHz
FREQUENCY STABILITY*	Option A			± 25	PPM
	Option B			± 50	PPM
OPERATING TEMPERATURE		0°		+70°	°C
STORAGE TEMPERATURE		-40°		+85°	°C
FREQUENCY CONTROL RANGE	Option 1	± 50			PPM
	Option 2	± 100			PPM
	Option 3**	± 150			PPM
INPUT VOLTAGE		+2.97	+3.3	+3.63	V DC
CONTROL VOLTAGE		+0.0	+1.65	+3.3	V DC
INPUT CURRENT				20	mA
ABSOLUTE CLOCK JITTER				± 100	ps
SYMMETRY	@ 1/2 Vcc Level	40/60		60/40	%
RISE AND FALL TIMES				5	ns
OUTPUT VOLTAGE	VOL			Vcc x 0.1V	V DC
	VOH	Vcc x 0.9V			V DC
LOAD				15	pF
FREQUENCY LINEARITY				$\pm 20\%$	
START-UP TIME				10	ms

*Inclusive of +25°C tolerance, operating temperature range, input voltage change and load change.

**Not available at all frequencies

PACKAGE DIMENSIONS (mm)

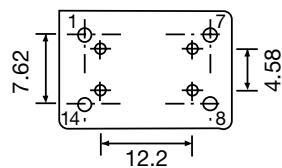
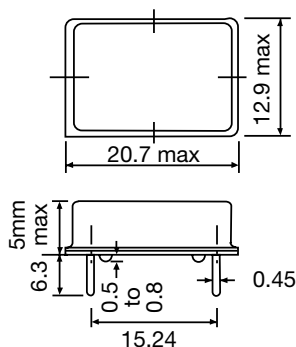

PIN CONNECTIONS	
#1	CONTROL VOLTAGE
#7	CASE GROUND
#8	OUTPUT
#14	SUPPLY VOLTAGE

Figure 1) ECX-VXO-143 – Top, Bottom and Side views

PIN CONNECTIONS	
#1	CONTROL VOLTAGE
#4	CASE GROUND
#5	OUTPUT
#8	SUPPLY VOLTAGE

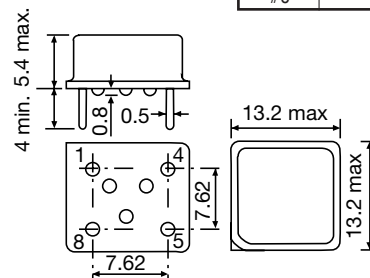
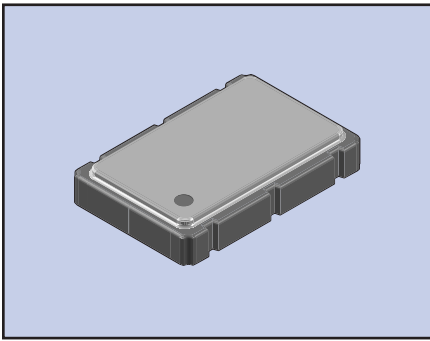

Figure 1) ECX-VXO-83 – Side, Bottom and Top views



The ECS-VXO-73 (3.3V) and ECS-VXO-75 (5.0V) are miniature VCXO'S voltage controlled crystal oscillators with tri-state in a ceramic SMD package. The low profile package is ideal for todays advanced portable PC and instrumentation applications.

FEATURES

- 3.3V & 5.0V versions
- 1.6 mm profile
- Low power consumption
- Tri-State
- Seam welded package
- Tape & Reel (1,000 pcs STD)

PART NUMBERING GUIDE

SERIES	FREQUENCY (27.0 MHz)
ECS-VXO-73	270

Sample Part Number: ECS-VXO-73-270. 3.3V. 27.000 MHz VCXO

OPERATING CONDITIONS/ELECTRICAL CHARACTERISTICS

PARAMETERS	CONDITIONS	ECS-VXO-73 (3.3V)			ECS-VXO-75 (5.0V)			UNITS
		MIN	TYP	MAX	MIN	TYP	MAX	
FREQUENCY RANGE		3.000		77.760	3.000		77.760	MHz
TEMPERATURE RANGE	Operating	-10		+70	-10		+70	°C
	Storage	-40		+85	-40		+85	°C
SUPPLY VOLTAGE		+3.14	+3.3	+3.465	+4.75	+5.0	+5.25	V DC
FREQUENCY STABILITY*	All Conditions			±50			±50	PPM
FREQUENCY PULLING RANGE		±90			±100			PPM
CONTROL VOLTAGE		0	+1.65	+3.3	+0.5	+2.5	+4.5	V DC
FREQUENCY LINEARITY	Positive Slope			±15			±10	%
INPUT CURRENT	No Load			20			40	mA
OUTPUT SYMMETRY	@ 1/2 Vcc Level	40/60		60/40	40/60		60/40	%
RISE AND FALL TIMES				5			5	ns
LOGIC "0" LEVEL				10% Vcc			10% Vcc	V DC
LOGIC "1" LEVEL		90% Vcc			90% Vcc			V DC
LOAD	CMOS			15			15	pF
START-UP TIME				10			10	ms
MODULATION BANDWIDTH	(-3 dB)	10			10			KHz
DISABLE TIME				100			100	ns

* Inclusive of 25°C tolerance, operating temperature range, input voltage change, load change, aging shock and vibration.
 Note: A 0.01-0.1 µF bypass capacitor should be placed between Vcc (Pad 6) and GND (Pad 3) for stable oscillation and to minimize power line noise.

PACKAGE DIMENSIONS (mm)

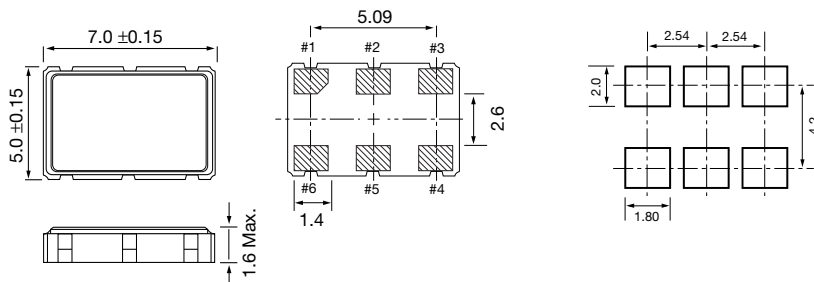
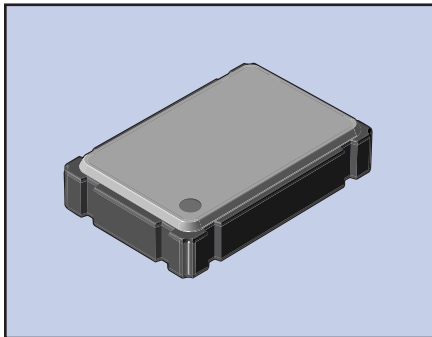

Figure 1) ECS-VXO-73/VXO-75 Top and Side view

Figure 2) Land Pattern

PIN CONNECTIONS	
#1	V CONTROL
#2	TRI-STATE
#3	GND
#4	OUTPUT
#5	NC
#6	VCC

ECS-VXO-73/VXO-75 TRI-STATE CONTROL VOLTAGE		
VXO-73, PAD 2	VXO-75, PAD 2	PAD 4
OPEN	OPEN	OSCILLATION
+2.2V MIN	+3.5V MIN	OSCILLATION
+0.8V MIN	+1.5V MIN	HIGH IMPEDANCE



The ECS-VXO-97 offers the frequency control of a VCXO in a SMD, ceramic package. Frequency can be pulled up to ± 100 ppm by varying the control voltage of 2.5V by up to $\pm 2.0V$.

FEATURES

- 2.0 mm low profile
- Waveform symmetry of 40/60%
- SMD version
- 3.3V operation (optional)
- Tape & Reel (1000 pcs)

PART NUMBERING GUIDE "EXAMPLE"

	FREQUENCY (16.0 MHz)	FREQUENCY CONTROL RANGE
ECS-VXO-97	- 160	- A

OPERATING CONDITIONS/ELECTRICAL CHARACTERISTICS

PARAMETERS	CONDITIONS	MINIMUM	TYPICAL	MAXIMUM	UNITS	
FREQUENCY RANGE	F_0	8.000		40.000	MHz	
FREQUENCY STABILITY	All conditions	-30		+30	PPM	
FREQUENCY CONTROL RANGE	(A)	$V_C = +2.5 \text{ VDC} \pm 2.0V$	-50	+50	PPM	
	(B)	$V_C = +2.5 \text{ VDC} \pm 2.0V$	-75	+75	PPM	
	(C)	$V_C = +2.5 \text{ VDC} \pm 2.0V$	-100	+100	PPM	
OPERATING TEMPERATURE	T_{OPR}	-10		+60	$^{\circ}\text{C}$	
STORAGE TEMPERATURE	T_{STG}	-30		+85	$^{\circ}\text{C}$	
INPUT VOLTAGE (V_{CC})		+4.75	+5	+5.25	V DC	
CONTROL VOLTAGE (V_C)		+0.5	+2.5	+4.5	V DC	
INPUT CURRENT				25	mA	
OUTPUT (-10° TO +70°C)	SYMMETRY	at 1/2 V_{CC} Level	40/60	50 \pm 10	60/40	%
	RISE AND FALL TIMES			10		ns
	"0" LEVEL			$V_{CC} \times 0.1V$		V
	"1" LEVEL		$V_{CC} \times 0.9V$			V
LOAD	HCMOS			15	pF	
FREQUENCY LINEARITY		-10		+10	%	
RISE AND FALL TIMES				10	ms	

PACKAGE DIMENSIONS (mm)

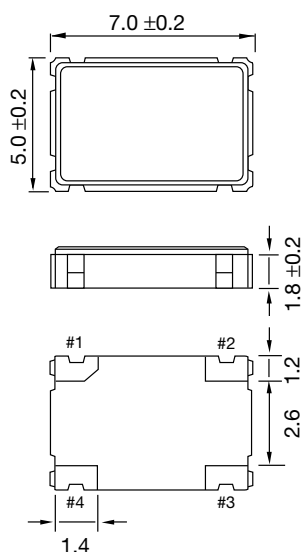

Figure 1) ECS-VXO-97 – Top, Side and Bottom views

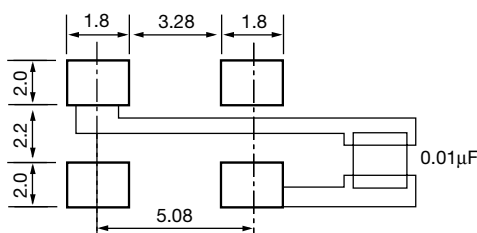
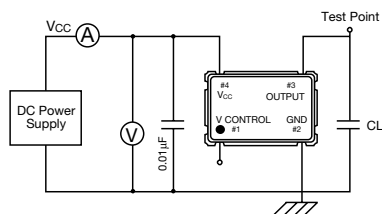

Figure 2) Land Pattern



CL: Including fixture and probe capacitance.

Figure 3) Test Circuit

PIN CONNECTIONS	
#1	V CONTROL
#2	GND
#3	OUTPUT
#4	V_{CC}

PACKAGE DATA	
COVER	METAL
BASE	CERAMIC
SEALING	SEAM-WELD
TERMINAL PLATING	GOLD

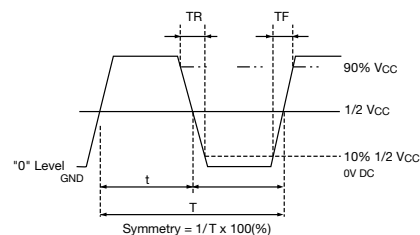

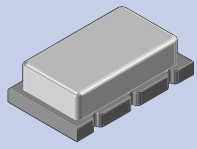
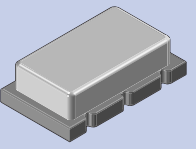
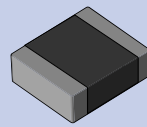

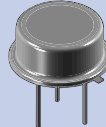
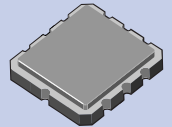
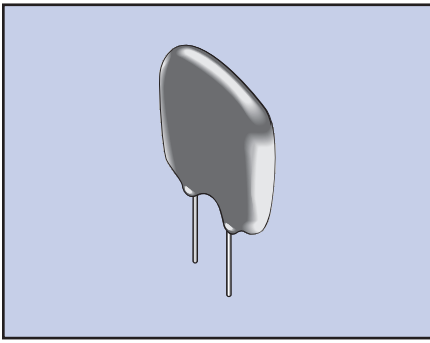

Figure 4) Output Wave Form

PRODUCT	ZTA SERIES CERAMIC RESONATORS	ZTT SERIES CERAMIC RESONATOR	ECS-SR-A SERIES SMD CERAMIC RESONATOR	ECS-SR-B SERIES SMD CERAMIC RESONATOR
PRODUCT ILLUSTRATION				
FREQUENCY RANGE	2.0 ~ 50 MHz	2.0 ~ 50 MHz	2.0 ~ 30 MHz	2.0 ~ 30 MHz
FREQUENCY TOLERANCE @ +25°C	±0.5%	±0.5%	±0.5	±0.5
FREQUENCY STABILITY	±0.3%	±0.3%	±0.3%	±0.3%
TEMPERATURE RANGE	-20 ~ +80°C	-20 ~ +80°C	-20 ~ +80°C	-20 ~ +80°C
FEATURES	<ul style="list-style-type: none"> • Wide Frequency Range • Low Profile • Extended Temp Range • High Stability 	<ul style="list-style-type: none"> • Wide Frequency Range • Low Profile • Extended Temp Range • Built-in Load Capacitor 	<ul style="list-style-type: none"> • Wide Frequency Range • Low Profile SMD • Low Cost 	<ul style="list-style-type: none"> • Wide Frequency Range • Low Profile SMD • Built-in Load Capacitor
PAGE #	63	64	65	66

PRODUCT	ECS-CR1/ECS-CR2 SMD CERAMIC RESONATOR	ZTB/ZTBF CERAMIC RESONATOR	ECS-DR1/ECS-DR2 SERIES 1 PORT & 2 PORT SAW RESONATOR	ECS-SDR1 SERIES 1 PORT SAW RESONATOR
PRODUCT ILLUSTRATION				
FREQUENCY RANGE	8 ~ 40 MHz	190 ~ 1250 MHz	300 ~ 460 MHz	310 ~ 434 MHz
FREQUENCY STABILITY	±0.590%	±0.5%	0.037 PPM/°C	0.032 PPM/°C
TEMPERATURE RANGE	-20 ~ +90°C	-20 ~ +80°C	-40 ~ +85°C	-40 ~ +85°C
FEATURES	<ul style="list-style-type: none"> • Wide Frequency Range • Chip Type SMD • Low Cost 	<ul style="list-style-type: none"> • High Accuracy • Low Cost • Stable Environmental Performance 	<ul style="list-style-type: none"> • Quartz Stability • Hermetic T039-3A Package • Industry Std. Footprint 	<ul style="list-style-type: none"> • Quartz Stability • Low Loss • SMD Package
PAGE #	67-68	69	70-71	72



The ZTA Series ceramic resonator offers wide frequency range and extended temperature range capabilities.

FEATURES

- Low profile
- Wide frequency range
- Extended temperature range
- High stability
- Radial taping available

OPERATING CONDITIONS/ELECTRICAL CHARACTERISTICS

PART NUMBER *	FREQUENCY RANGE (MHz)	FREQUENCY ACCURACY @ 25° (%)	STABILITY IN TEMPERATURE -20° ~ 80°C (%)	AGING FOR TEN YEARS (%)	RESONANT RESISTANCE (Ω) MAX.	WITHSTANDING VOLTAGE (5 SEC. MAX.)	INSULATION RESISTANCE (Ω)
ZTA□.□□MG	2.00 ~ 2.99	±0.5	±0.3	±0.3	80	100 V DC	5X10 ⁸ Min. @ 10 V DC
ZTA□.□□MG	3.00 ~ 3.49	±0.5	±0.3	±0.3	50	100 V DC	5X10 ⁸ Min. @ 10 V DC
ZTA□.□□MG	3.50 ~ 4.99	±0.5	±0.3	±0.3	30	100 V DC	5X10 ⁸ Min. @ 10 V DC
ZTA□.□□MT	5.00 ~ 6.99	±0.5	±0.3	±0.3	30	100 V DC	5X10 ⁸ Min. @ 10 V DC
ZTA□.□□MT	7.00 ~ 13.00	±0.5	±0.3	±0.3	25	100 V DC	5X10 ⁸ Min. @ 10 V DC
ZTA□.□□MX	13.01 ~ 50.00	±0.5	±0.3	±0.3	55	100 V DC	5X10 ⁸ Min. @ 10 V DC

* Complete part number to include frequency i.e. ZTA-4.00MG (4.00 = 4.00 MHz)

PACKAGE DIMENSIONS (mm)

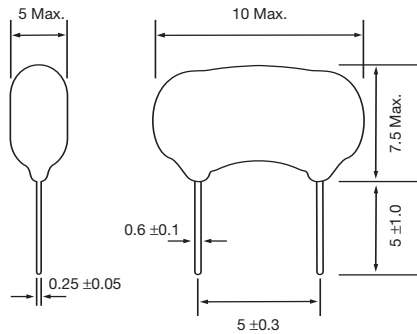

Figure 1) ZTA □.□□ MG, Front and Side views

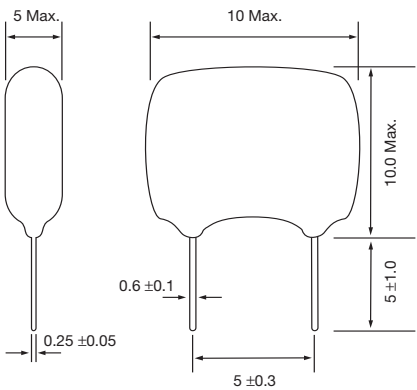

Figure 3) ZTA □.□□ MT, MX Front and Side views

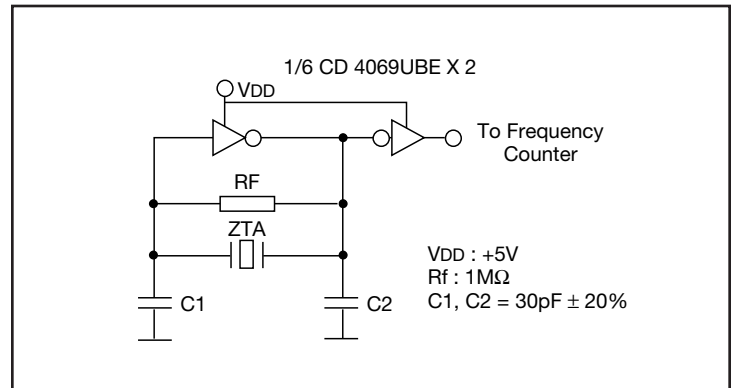

Figure 2) ZTA □.□□ MG Test Circuit

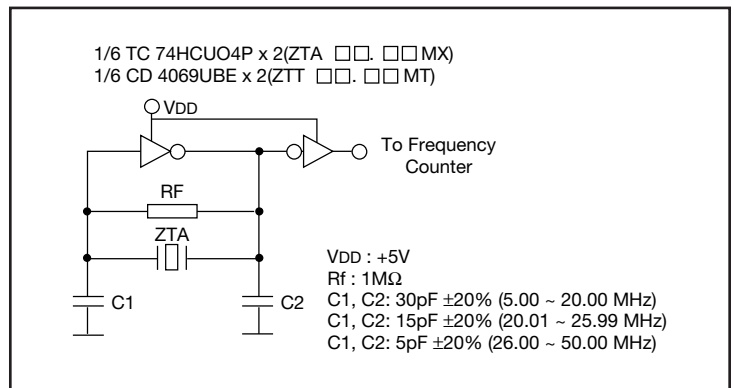
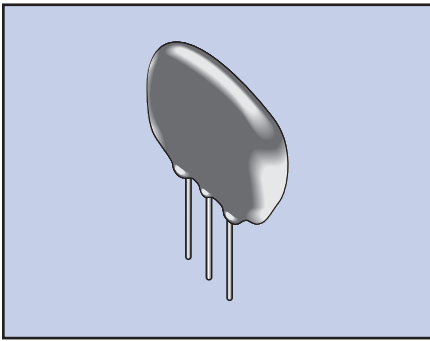

Figure 4) ZTA □.□□ MT & ZTA □.□□ MX Test Circuit



The ZTT Series ceramic resonator offers wide frequency range and extended temperature range capabilities with built-in load capacitance.

FEATURES

- Low profile
- Wide frequency range
- Extended temperature range
- High stability
- Built-in load capacitance
- Radial taping available

OPERATING CONDITIONS/ELECTRICAL CHARACTERISTICS

PART NUMBER *	FREQUENCY RANGE (MHz)	FREQUENCY ACCURACY @ 25° (%)	STABILITY IN TEMPERATURE -20° ~ 80°C (%)	AGING FOR TEN YEARS (%)	RESONANT RESISTANCE (Ω) MAX.	WITHSTANDING VOLTAGE (5 SEC. MAX.)	INSULATION RESISTANCE (Ω)
ZTT□.□□MG	2.00 ~ 2.99	±0.5	±0.3	±0.3	80	100 V DC	5X10 ⁸ Min. @ 10 V DC
ZTT□.□□MG	3.00 ~ 3.49	±0.5	±0.3	±0.3	50	100 V DC	5X10 ⁸ Min. @ 10 V DC
ZTT□.□□MG	3.50 ~ 4.99	±0.5	±0.3	±0.3	30	100 V DC	5X10 ⁸ Min. @ 10 V DC
ZTT□.□□MT	5.00 ~ 6.99	±0.5	±0.3	±0.3	30	100 V DC	5X10 ⁸ Min. @ 10 V DC
ZTT□.□□MT	7.00 ~ 13.00	±0.5	±0.3	±0.3	25	100 V DC	5X10 ⁸ Min. @ 10 V DC
ZTT□.□□MX	13.01 ~ 50.00	±0.5	±0.3	±0.3	55	100 V DC	5X10 ⁸ Min. @ 10 V DC

* Complete part number to include frequency i.e. ZTT10.00MT (10.00 = 10.00 MHz)

PACKAGE DIMENSIONS (mm)

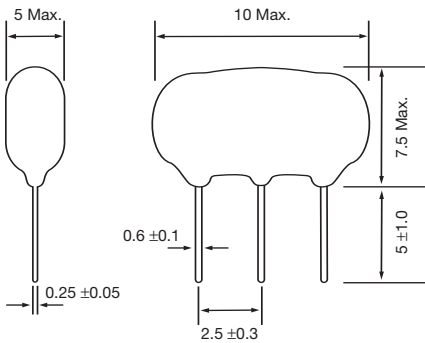

Figure 1) ZTT □.□□MG, Front and Side views

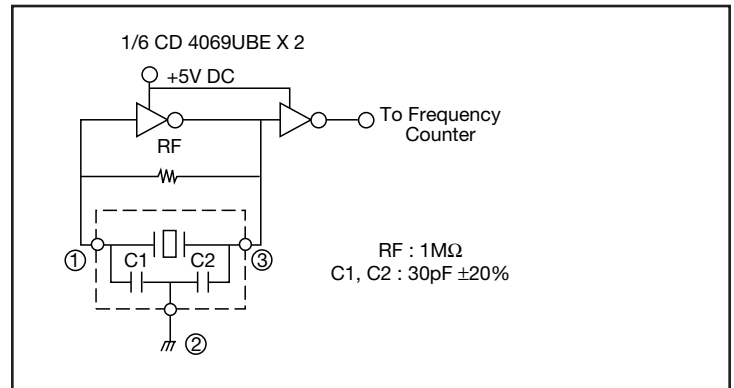

Figure 2) ZTT □.□□MG Test Circuit

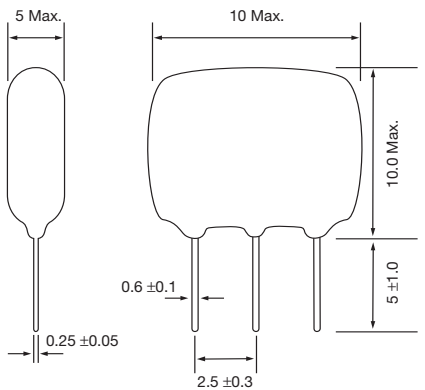

Figure 3) ZTT □.□□MT, MX Front and Side views

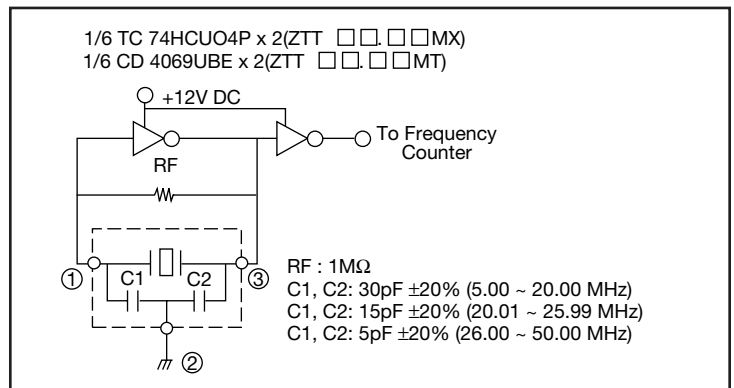
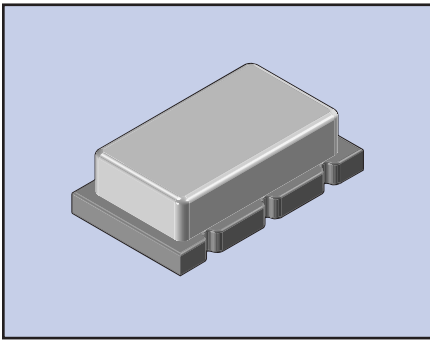

Figure 4) ZTT □.□□MT & ZTT □.□□MX Test Circuit



The ECS-SR-A Series SMD ceramic resonator is an excellent low cost frequency control solution when absolute frequency accuracy is not important.

FEATURES

- Low profile SMD package
- Wide frequency range
- Tape & Reel packaging

PART NUMBERING GUIDE "EXAMPLE"

MANUFACTURER	PACKAGE TYPE	FREQUENCY	VERSION	TAPE AND REEL PACKAGING
ECS	- SR1	- 4.00	- A	- TR

Sample Part Number: ECS-SR1-4.00-A-TR, Tape & Reel Packaging

OPERATING CONDITIONS/ELECTRICAL CHARACTERISTICS

PART NUMBER *	FREQUENCY RANGE (MHz)	FREQUENCY ACCURACY @ 25°C (%)	FREQUENCY STABILITY -20 ~ 80°C (%)	AGING FOR TEN YEARS (%)	RESONANT RESISTANCE (Ω) MAX.	INSULATION RESISTANCE @ 10 VDC
ECS-SR1-□-□□-B	2.00 ~ 8.0	±0.5	±0.3	±0.3	40	100 M Ω Min.
ECS-SR2-□-□□-B	8.01 ~ 13.00	±0.5	±0.3	±0.3	30	100 M Ω Min.
ECS-SR3-□-□□-B	13.1 ~ 20.00	±0.5	±0.3	±0.3	30	100 M Ω Min.
ECS-SR4-□-□□-B	20.1 ~ 30.00	±0.5	±0.3	±0.3	55	100 M Ω Min.

Complete part number to include frequency i.e. ECS-SR1-4.00-A-TR

PACKAGE DIMENSIONS (mm)

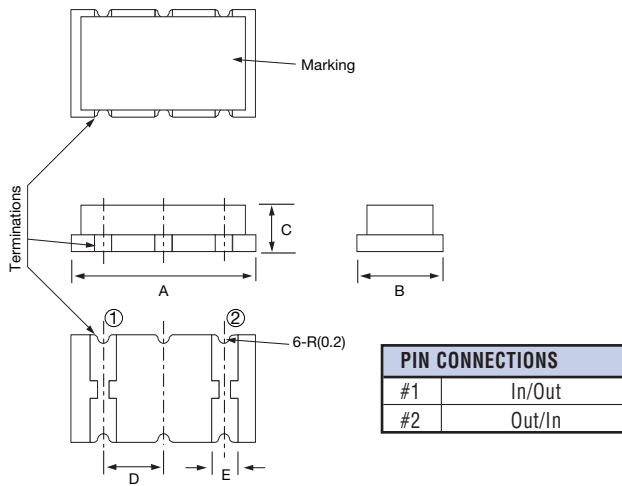

Figure 1) ECS-SR-A Series - Top, Side, Bottom & End views

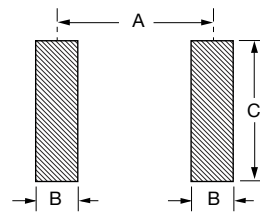
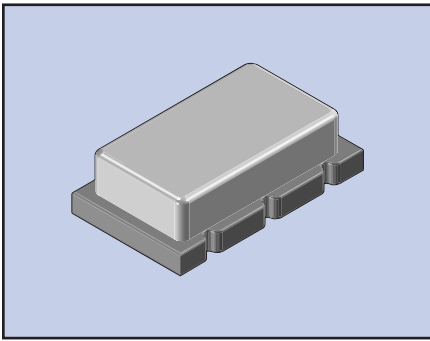

Figure 2) Land Pattern

PACKAGE TYPE	DIMENSIONS (mm)				
	A	B	C	D	E
ECS-SR1	7.5	3.3	1.8	2.5	1.5
ECS-SR2	8.3	3.5	1.8	2.5	1.0
ECS-SR3	6.0	3.5	1.8	1.9	1.2
ECS-SR4	6.0	5.0	1.8	1.9	1.2

PACKAGE TYPE	DIMENSIONS (mm)		
	A	B	C
ECS-SR1	5.0	1.7	4.0
ECS-SR2	5.0	1.2	4.7
ECS-SR3	3.8	1.2	4.2
ECS-SR4	3.8	1.2	5.5



The ECS-SR-B Series SMD ceramic resonator includes built-in capacitors for simplification of oscillator circuits and reduces component count. The SMD ceramic resonator is an excellent low cost frequency control solution when absolute frequency accuracy is not important.

FEATURES

- Low profile SMD package
- Wide frequency range
- Built-in load capacitor
- Tape & Reel packaging

PART NUMBERING GUIDE "EXAMPLE"

MANUFACTURER	PACKAGE TYPE	FREQUENCY	VERSION	TAPE AND REEL PACKAGING
ECS	- SR1	- 4.00	- B	- TR

Sample Part Number: ECS-SR1-4.00-B-TR, Tape & Reel Packaging

OPERATING CONDITIONS/ELECTRICAL CHARACTERISTICS

PART NUMBER *	FREQUENCY RANGE (MHz)	FREQUENCY ACCURACY @ 25°C (%)	FREQUENCY STABILITY -20° ~ 80°C (%)	AGING FOR TEN YEARS (%)	RESONANT RESISTANCE (Ω) MAX.	INTERNAL CAPACITANCE C1 & C2	INSULATION RESISTANCE @ 10 VDC
ECS-SR1-□-□□-B	2.00 ~ 8.0	±0.5	±0.3	±0.3	40	30 pF	100 M Ω Min.
ECS-SR2-□-□□-B	8.01 ~ 13.00	±0.5	±0.3	±0.3	40	30 pF	100 M Ω Min.
ECS-SR3-□-□□-B	13.1 ~ 20.00	±0.5	±0.3	±0.3	30	30 pF	100 M Ω Min.
ECS-SR4-□-□□-B	20.1 ~ 30.00	±0.5	±0.3	±0.3	55	30 pF	100 M Ω Min.

Complete part number to include frequency i.e. ECS-SR1-4.00-B-TR

PACKAGE DIMENSIONS (mm)

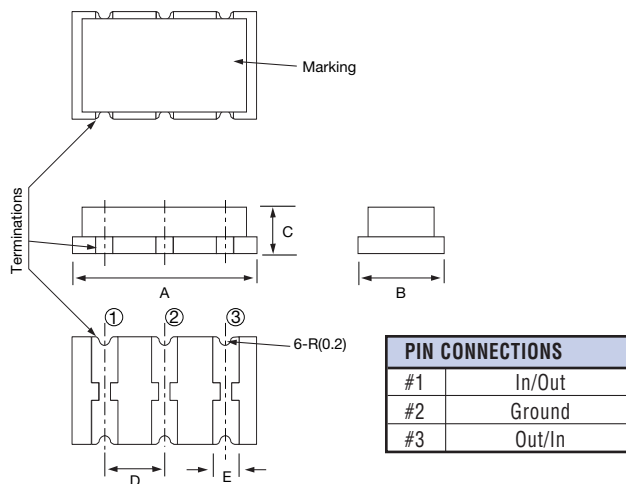

Figure 1) ECS-SR-B Series - Top, Side, Bottom & End views

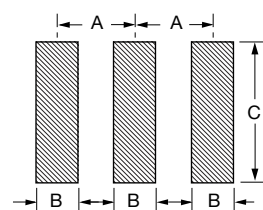
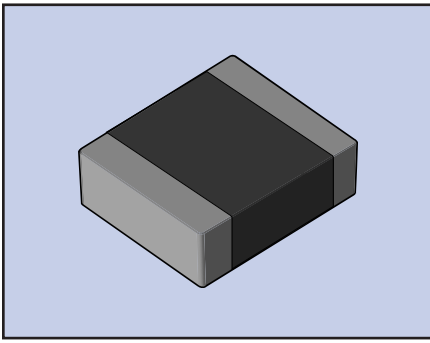

Figure 2) Land Pattern

PACKAGE TYPE	DIMENSIONS (mm)				
	A	B	C	D	E
ECS-SR1	7.5	3.3	2.2	2.5	1.5
ECS-SR2	8.3	3.5	1.8	2.5	1.0
ECS-SR3	6.0	3.5	1.8	1.9	1.2
ECS-SR4	6.0	5.0	1.8	1.9	1.2

PACKAGE TYPE	DIMENSIONS (mm)			
	A	B	C	D
ECS-SR1	2.5	1.5	4.0	1.7
ECS-SR2	2.5	1.2	4.7	1.2
ECS-SR3	1.9	1.2	4.2	1.2
ECS-SR4	1.9	1.2	5.5	1.2



The ECS-CR-1/CR-2-A Chip Type SMD ceramic resonator is an excellent low cost frequency control solution when absolute frequency accuracy is not important.

FEATURES

- Chip Type SMD package
- Wide frequency range
- Tape & Reel packaging (1,000 pcs. per reel)

PART NUMBERING GUIDE "EXAMPLE"

MANUFACTURER	PACKAGE TYPE	FREQUENCY	VERSION	TAPE AND REEL PACKAGING
ECS	- CR1	- 10.00	- A	- TR

Sample Part Number: ECS-CR-1-10.00-A-TR

OPERATING CONDITIONS/ELECTRICAL CHARACTERISTICS

PART NUMBER *	FREQUENCY RANGE (MHz)	FREQUENCY ACCURACY @ 25°C (%)	FREQUENCY STABILITY -20° ~ 80°C (%)	AGING FOR TEN YEARS (%)	RESONANT RESISTANCE (Ω) MAX.	INSULATION RESISTANCE @ 10 VDC
ECS-CR1-□-□□-A	8.00 ~ 13.00	±0.5	±0.3	±0.5	25	100 M Ω Min.
	13.01 ~ 50.00	±0.5	±0.3	±0.5	40	100 M Ω Min.
ECS-CR2-□-□□-A	10.00 ~ 40.00	±0.5	±0.3	±0.5	40	100 M Ω Min.

Complete part number to include frequency i.e. ECS-CR1-10.00-B-TR

PACKAGE DIMENSIONS (mm)

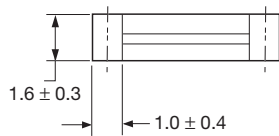
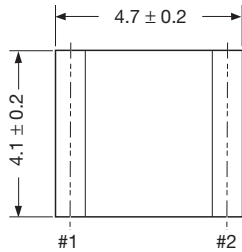

Figure 1) ECS-CR-1-A Series - Top & Side views

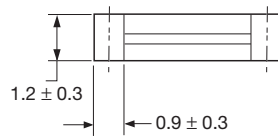
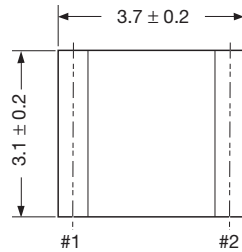

Figure 2) ECS-CR-2-A Series - Top & Side views

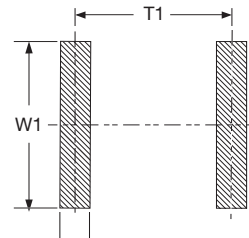
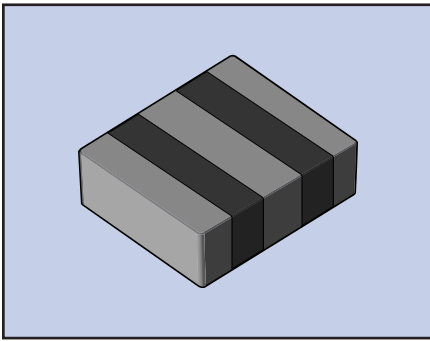

Figure 3) Land Pattern

PAD CONNECTIONS	
#1	In/Out
#2	Out/In

DIMENSIONS	CR1	CR2
T1	3.9±0.2	3.0±0.2
T2	0.8±0.2	0.7±0.2
W1	5.1±0.2	4.1±0.2



The ECS-CR-1/CR-2-B Chip Type SMD ceramic resonator includes built in capacitors for simplification of oscillator circuits and reduces component count. The SMD ceramic resonator is an excellent low cost frequency control solution when absolute frequency accuracy is not important.

FEATURES

- Chip Type SMD package
- Wide frequency range
- Built-in load capacitor
- Tape & Reel packaging (1,000 pcs. per reel)

PART NUMBERING GUIDE "EXAMPLE"

MANUFACTURER	PACKAGE TYPE	FREQUENCY	VERSION	TAPE AND REEL PACKAGING
ECS	- CR1	- 10.00	- B	- TR

Sample Part Number: ECS-CR-1-10.00-A-TR

OPERATING CONDITIONS/ELECTRICAL CHARACTERISTICS

PART NUMBER *	FREQUENCY RANGE (MHz)	FREQUENCY ACCURACY @ 25°C (%)	FREQUENCY STABILITY -20° ~ 80°C (%)	AGING FOR TEN YEARS (%)	RESONANT RESISTANCE (Ω) MAX.	INSULATION RESISTANCE @ 10 VDC
ECS-CR1-□-□□-B	8.00 ~ 40.00	±0.5	±0.4	±0.3	40	100 M Ω Min.
ECS-CR2-□-□□-B	10.00 ~ 40.00	±0.5	±0.3	±0.3	40	100 M Ω Min.

Complete part number to include frequency i.e. ECS-CR1-10.00-B-TR

PACKAGE DIMENSIONS (mm)

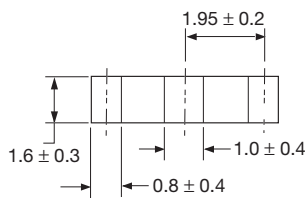
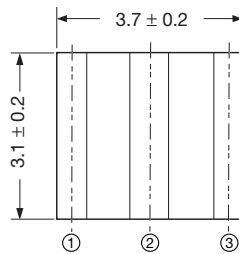
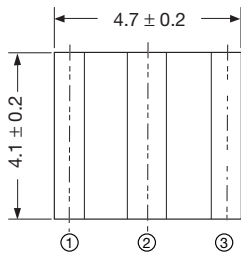

Figure 1) ECS-CR-1-A Series - Top & Side views

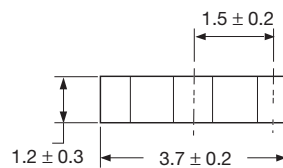

Figure 2) ECS-CR-2-A Series - Top & Side views

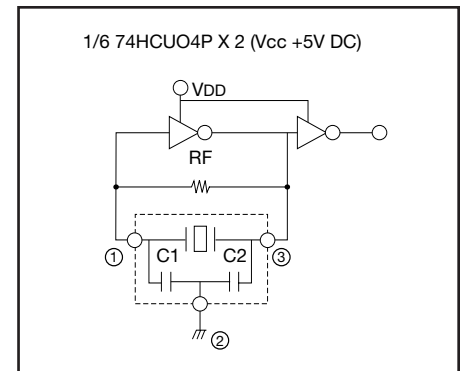

Figure 3) Test Circuit

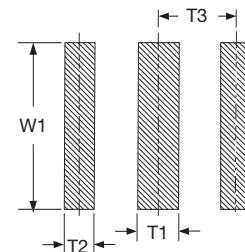
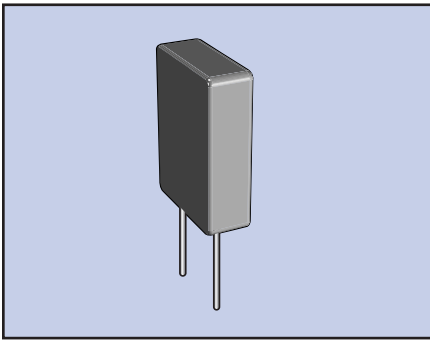

Figure 4) Land Pattern

PAD CONNECTIONS	
#1	In/Out
#2	GROUND
#3	Out/In

DIMENSIONS	CR1	CR2
T1	1.3±0.2	1.0±0.2
T2	0.8±0.2	0.7±0.2
T3	1.95±0.2	1.5±0.2
W1	5.1±0.2	4.1±0.2



The ZTB Series ceramic resonator offers low frequency and extended temperature range capabilities. The ZTBF option is a formed lead version for SMD applications.

FEATURES

- Low frequencies
- Extended temperature range
- High stability

OPERATING CONDITIONS/ELECTRICAL CHARACTERISTICS

PART NUMBER *	FREQUENCY RANGE (KHz)	FREQUENCY ACCURACY @ 25°	STABILITY IN TEMPERATURE -20° ~ 80°C (%)	AGING FOR TEN YEARS (%)	RESONANT RESISTANCE (Ω) MAX.	C1 (pF)	C2 (pF)
ZTB□□□D	190 ~ 249	±1.0 KHz	±0.3%	±0.5	20	330	470
ZTB□□□D	250 ~ 374	±1.0 KHz	±0.3%	±0.5	20	220	470
ZTB□□□P	375 ~ 429	±2.0 KHz	±0.3%	±0.5	20	120	470
ZTB□□□E	430 ~ 449	±2.0 KHz	±0.3%	±0.5	20	100	100
ZTB□□□E	450 ~ 509	±2.0 KHz	±0.3%	±0.5	20	100	100
ZTB□□□P	510 ~ 699	±2.0 KHz	±0.3%	±0.5	35	100	100
ZTB□□□J	700 ~ 999	±0.5 %	±0.3%	±0.5	70	100	100
ZTB□□□MJ	1000 ~ 1250	±0.5 %	±0.3%	±0.5	100	100	100

* Complete part number to include frequency i.e. ZTB500E (500 = 500 KHz)

PACKAGE DIMENSIONS (mm)

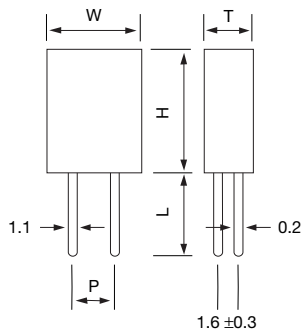

Figure 1) ZTB□□□D, Front and Side views

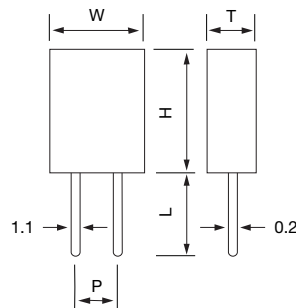

Figure 2) ZTB□□□P, E, J, MJ Front and Side views

FREQ. RANGE (KHz)	DIMENSIONS (mm)				
	W	T	H	P	L
190-249	13.5	3.8	14.7	10.0	8.0
250-374	11.0	3.8	12.2	7.7	7.0

FREQ. RANGE (KHz)	DIMENSIONS (mm)				
	W	T	H	P	L
375-449	7.9	3.6	9.3	5.0	5.0
450-699	7.0	3.5	9.0	5.0	5.0
700-1250	5.0	2.2	6.0	2.5	3.5

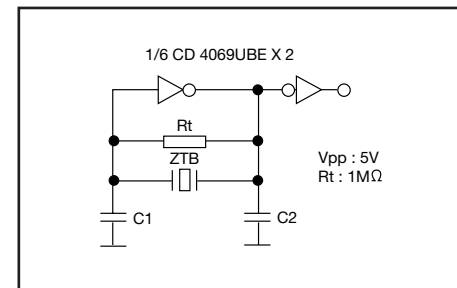

Figure 4) ZTB Test Circuit

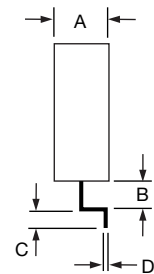
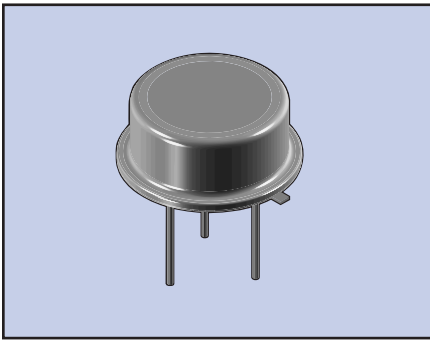

Figure 3) ZTBF (formed lead option) Side views

PART NUMBER	FREQ. RANGE	A	B	C	D
ZTBF□□□P	375-429	3.6±0.5	0.9±0.3	1.5±0.3	0.15±0.05
ZTBF□□□E	430-509	3.5±0.5	0.9±0.3	1.5±0.3	0.15±0.05
ZTBF□□□P	510-699	3.5±0.5	0.9±0.3	1.5±0.3	0.15±0.05
ZTBF□□□J	700-999	2.2±0.5	0.6±0.3	1.0±0.3	0.12±0.05
ZTBF□□□MJ	1000-1250	2.2±0.5	0.6±0.3	1.0±0.3	0.12±0.05



The ECS-DR1 Series are 1-port SAW (Surface Acoustic Wave) resonators in a thru-hole TO39-3A package. They offer a fundamental mode, quartz frequency and are ideal for remote control and wireless security transmitters.

FEATURES

- Quartz Stability
- Ideal for wireless security and remote control applications

PART NUMBERING GUIDE

ECS SERIES	FREQUENCY (318.00 MHz)
ECS-DR1	3180

OPERATING CONDITIONS/ELECTRICAL CHARACTERISTICS

PARAMETERS	SYMBOL/NOTES	DR1-3100	DR1-3150	DR1-3180	DR1-4180	DR1-4339	UNITS
CENTER FREQUENCY	F_0	310.0 ±0.1	315.0 ±0.1	318.0 ±0.075	418.0 ±0.075	433.92 ±0.075	MHz
INSERTION LOSS	IL	2.0	2.0	2.0	2.0	2.0	dB Max.
UNLOADED Q		13,900	13,900	11,000	13,900	13,900	
50 Ohms LOADED Q		2,100	2,100	2,100	2,100	2,100	
TURNOVER TEMPERATURE		10/40	10/40	10/40	5/40	10/40	°C
FREQ. TEMP. COEFFICIENT	FTC	0.037	0.037	0.037	0.037	0.037	ppm/°C
FREQUENCY AGING		< ±10	< ±10	< ±10	< ±10	< ±10	ppm/year
DC INSULATION RESISTANCE	Between any 2 pins	>1	>1	>1	>1	>1	M Ohms
MAX. DC VOLTAGE	Between any 2 pins	10	10	10	10	30	VDC
PIN 1-TO-2 STATIC CAPACITANCE		2.5 ±0.3	2.5 ±0.3	2.3 ±0.3	2.3 ±0.3	2.0 ±0.3	pF
TRANSDUCER STATIC CAPACITANCE		2.2	2.2	2.2	1.7	1.7	pF
OPERATING TEMPERATURE	T_{OPR}	-40 to +85	-40 to +85	-40 to +85	-40 to +85	-40 to +85	°C
STORAGE TEMPERATURE	T_{STG}	-40 to +85	-40 to +85	-40 to +85	-40 to +85	-40 to +85	°C
CASE		TO-39-3A	TO-39-3A	TO-39-3A	TO-39-3A	TO-39-3A	

PACKAGE DIMENSIONS (mm)

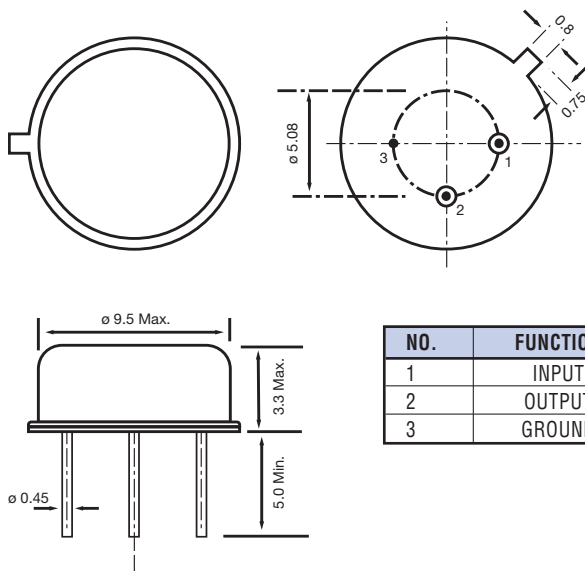

Figure 1) ECS-DR1 - Top, Side and Bottom views

NO.	FUNCTION
1	INPUT
2	OUTPUT
3	GROUND

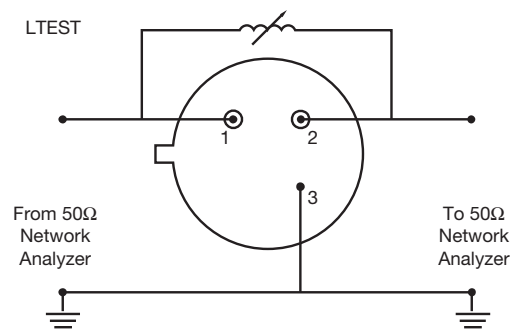
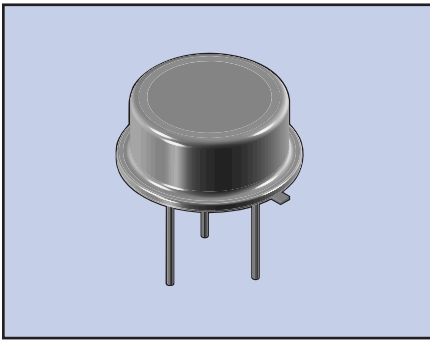

Figure 2) Test Circuit



The ECS-DR2 Series are 2-port 180° SAW (Surface Acoustic Wave) resonators in a thru-hole TO39-3A package. They offer a fundamental mode, quartz frequency and are ideal for remote control and wireless security transmitters.

FEATURES

- Quartz Stability
- 180° nominal insertion phase at resonance
- Ideal for wireless security and remote control applications

PART NUMBERING GUIDE

ECS SERIES	FREQUENCY (433.92 MHz)
ECS-DR2	4339

OPERATING CONDITIONS/ELECTRICAL CHARACTERISTICS

PARAMETERS	SYMBOL/NOTES	DR2-3100	DR2-3150	DR2-4073	DR2-4180	DR2-4339	UNITS
CENTER FREQUENCY	F_0	310.0 ±0.1	315.0 ±0.075	407.3 ±0.1	418.0 ±0.075	433.92 ±0.075	MHz
INSERTION LOSS	IL	10.0	10.0	10.0	10.0	10.0	dB Max.
UNLOADED Q		12,000	12,000	12,000	12,000	12,000	
50 Ohms LOADED Q		7,000	7,000	5,500	5,500	5,500	
TURNOVER TEMPERATURE		15/45	15/45	15/45	15/45	15/45	°C
FREQ. TEMP. COEFFICIENT	FTC	0.037	0.037	0.037	0.037	0.037	ppm/°C
FREQUENCY AGING		< ±10	< ±10	< ±10	< ±10	< ±10	ppm/year
DC INSULATION RESISTANCE	Between any 2 pins	>1	>1	>1	>1	>1	M Ohms
MAX. DC VOLTAGE	Between any 2 pins	10	10	10	10	30	VDC
PIN 1-TO-2 STATIC CAPACITANCE		1.4 ±0.3	1.4 ±0.3	1.4 ±0.3	1.4 ±0.3	1.3 ±0.3	pF
OPERATING TEMPERATURE	T_{OPR}	-40 to +85	-40 to +85	-40 to +85	-40 to +85	-40 to +85	°C
STORAGE TEMPERATURE	T_{STG}	-40 to +85	-40 to +85	-40 to +85	-40 to +85	-40 to +85	°C
CASE		TO-39-3A	TO-39-3A	TO-39-3A	TO-39-3A	TO-39-3A	

PACKAGE DIMENSIONS (mm)

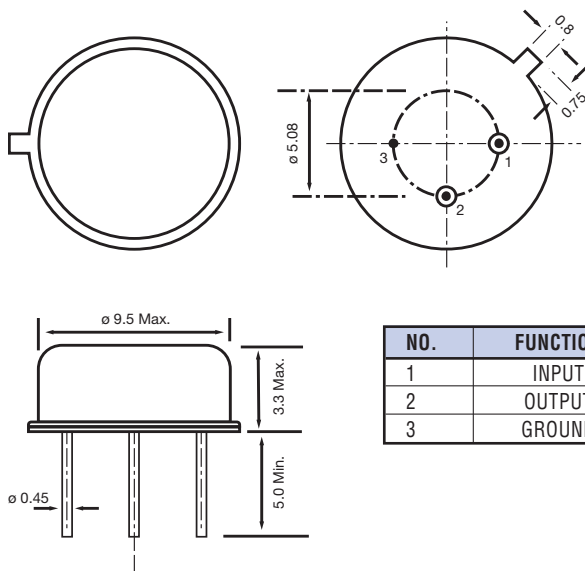

Figure 1) ECS-DR2 - Top, Side and Bottom views

NO.	FUNCTION
1	INPUT
2	OUTPUT
3	GROUND

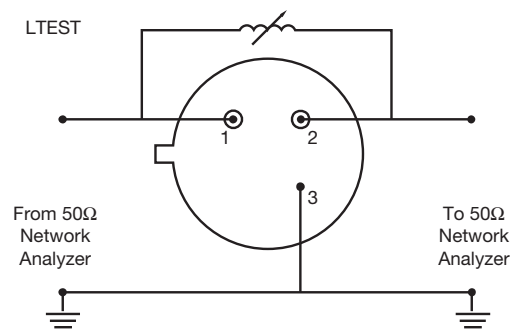
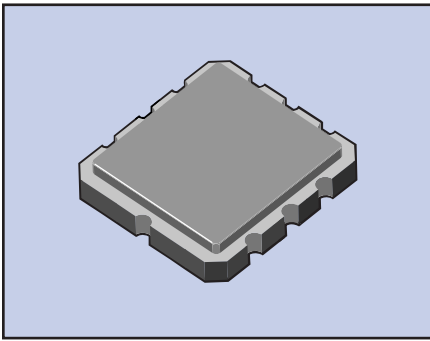

Figure 2) Test Circuit



FEATURES

- Ideal for transmitter applications
- Quartz stability
- Ultra miniature SMD package

PART NUMBERING GUIDE "EXAMPLE"

PART NUMBER	FREQUENCY ABBREVIATION (315.000 MHZ)	TAPE & REEL (1K/REEL)
ECS - 3150 - TR		

Sample Part Number: ECS-DR1-3150-TR



OPERATING CONDITIONS/ELECTRICAL CHARACTERISTICS

PARAMETERS	CONDITIONS	ECS-SDR1-3150			ECS-SDR1-4180			ECS-SDR1-4339			UNITS
		MIN	TYP	MAX	MIN	TYP	MAX	MIN	TYP	MAX	
CENTER FREQUENCY (fo)		314.925	315.000	315.075	418.925	418.000	418.075	433.845	433.920	433.995	MHz
FREQUENCY TOLERANCE				± 75			± 75			± 75	KHz
INSERTION LOSS			1.5	2.2		1.6	2.0		1.5	2.5	dB
QUALITY FACTOR	Unloaded		12,200			12,100			11,000		Q
	50Ω Unloaded		1,500			2,000			2,000		Q
TEMPERATURE STABILITY	Temperature Coefficient		0.032			0.032			0.032		ppm/°C
FREQUENCY AGING			<± 10			<± 10			<± 10		ppm/Yr
DC INSULATION RESISTANCE		1.0			1.0			1.0			MΩ
MOTIONAL RESISTANCE	R ₁		14	25		20	26		18	26	Ω
MOTIONAL INDUCTANCE	L ₁		86			91			86		pH
MOTIONAL CAPACITANCE	C ₁		2.95			1.6			1.56		fF
SHUNT CAPACITANCE	C ₀		2.4	2.7		2.0	2.3		2.0	2.3	pF
OPERATING TEMPERATURE		-40		+85	-40		+85	-40		+85	°C
STORAGE TEMPERATURE		-40		+85	-40		+85	-40		+85	°C

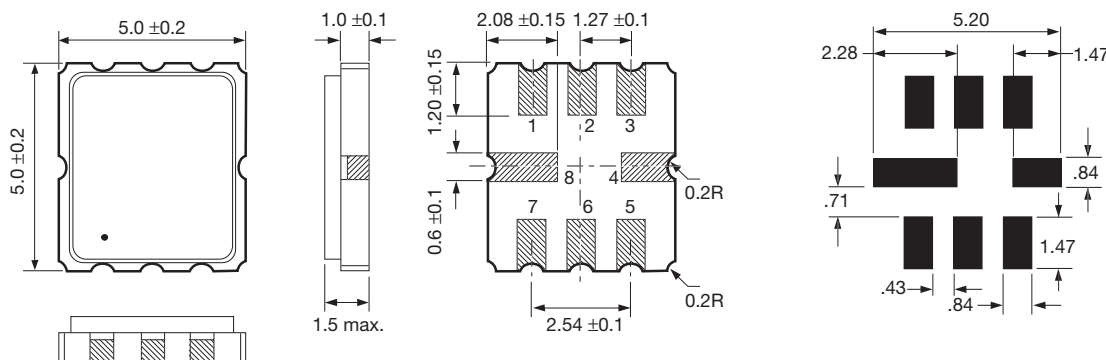
PACKAGE DIMENSIONS (mm)

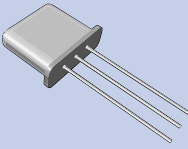
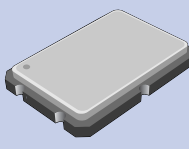
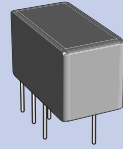

PIN CONNECTIONS	
#1	NO Connect
#2	Input
#3	NO Connect
#4	Ground
#5	NO Connect
#6	Output
#7	No Connect
#8	Ground

PRODUCT	THRU-HOLE MONOLITHIC CRYSTAL FILTERS (MCF)	ECS-96SMF SMD MCF	LTM450 & 455 KHz CERAMIC BPF'S	LTE SERIES CERAMIC BPF'S
PRODUCT ILLUSTRATION				
FREQUENCY RANGE	10.7 ~ 90 MHz	21.4 ~ 109.65 MHz	450 ~ 459 KHz	4.5 ~ 6.5 MHz
TEMPERATURE RANGE	-20 ~ +70°C	-30 ~ +85°C	-	-
FEATURES	<ul style="list-style-type: none"> • High Stability • Compact Package Size • Narrow & Intermediate Bandwidth Options • 2 ~ 10 Pole Response's 	<ul style="list-style-type: none"> • SMD MCF • 1.5 mm Profile • 2 Pole Response • 5 x 7 mm Footprint • Tape & Reel 	<ul style="list-style-type: none"> • Ultra Small Size • 2, 4, & 6 Element • Cost Effective • Wide Range of Bandwidths available 	<ul style="list-style-type: none"> • Wide Bandwidths • Low Insertion Loss • TV SIF Stage • Excellent Spurious Suppression Characteristics
PAGE #	74-76	77	78-82	83

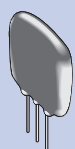
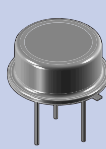
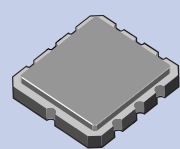
PRODUCT	XT SERIES CERAMIC TRAP	L10.7 SERIES CERAMIC BPF'S	ECS-D479.5B/D480A SERIES SAW FILTER	ECS-DSF400.0A-51/DSF947.5B-21 SAW FILTER
PRODUCT ILLUSTRATION				
FREQUENCY RANGE	4.5 ~ 6.5 MHz	10.64 ~ 10.76 MHz	479.5 & 480 MHz	400 & 947.5 MHz
TEMPERATURE RANGE	-	-	-25 ~ +85°C	-
FEATURES	<ul style="list-style-type: none"> • TV Ceramic Trap • Excellent Spurious Suppression Characteristics • Low Insertion Loss 	<ul style="list-style-type: none"> • Wide Bandwidths • Low Insertion Loss • IF Filter • Cost Effective 	<ul style="list-style-type: none"> • Wide Bandwidths • TO-39 Package • Cost-Effective 	<ul style="list-style-type: none"> • SMD Package • Cost-Effective
PAGE #	84	85	86	87

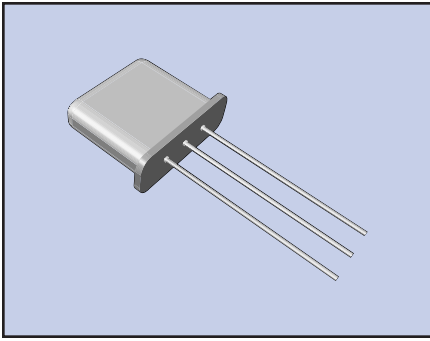

ECS's Monolithic Crystal Filters have very high Q's and excellent temperature and aging characteristics. These filters offer narrow and intermediate bandwidths. The monolithic crystal filter is smaller and more cost effective than a discrete crystal filter. With the addition of coupling capacitors between two-pole sections, they can be cascaded to produce four, six and eight (or more) pole filter responses.

FEATURES

- High stability for wide temperature ranges
- Sharp cut-off
- Low loss

ELECTRICAL CHARACTERISTICS (10.7 and 21.4 MHz)

For 12.5 KHz Channel Spacing (Operating Temperature -20 to +70°C)

MODEL	NOMINAL FREQ. (fo) (MHz)	NUMBER OF POLES	PASSBAND 3dB MIN. (KHz)	RIPPLE MAX. (dB)	INSERTION LOSS MAX. (dB)	STOPBAND MAX. (dB) (KHz)	STOPBAND MAX. (dB) (KHz)	GUARANTEED ATTENUATION (dB) (fo ±KHz)	TERMINATING IMPEDANCE (Ohms/pF)	CASE
ECS-10.7-7.5A	10.7	2	±3.75	0.5	1.5	20 ±18		35 +300 ~ +1000 50 -200 ~ -1000	1800//5.0	HC-49/U
ECS-10.7-7.5B	10.7	4	±3.75	1.0	2.5	40 ±14		65 +300 ~ +1000 80 -200 ~ -1000	1800//4.0	HC-49/U x 2
ECS-10.7-7.5C	10.7	6	±3.75	2.0	3.5	45 ±8.75	65 ±12.5	65 ±12.5 ~ ±300	1800//3.5	SC-3
ECS-10.7-7.5D	10.7	8	±3.75	2.0	4.0	65 ±8.75	90 ±12.5	90 ±12.5 ~ ±300	1800//3.5	SC-4
ECS-21K7.5A	21.4	2	±3.75	0.5	2.0	18 ±12.5		75 -910	1500//6.0	UM-1
ECS-21K7.5B	21.4	4	±3.75	1.0	2.5	35 ±12.5		90 ±910	850//5.0	UM-1 x 2
ECS-21K7.5C	21.4	6	±3.75	2.0	3.0	45 ±8.75	65 ±12.5	65 ±12.5 ~ ±300	850//5.0	SC-1
ECS-21K7.5D	21.4	8	±3.75	2.0	4.0	65 ±9	90 ±12.5	90 ±12.5 ~ ±300	850//5.0	SC-1
ECS-21K7.5E	21.4	10	±3.75	2.0	4.5	75 ±8.75	90 ±10.5	90 ±12.5 ~ ±300	850//5.0	SC-2

For 20 KHz Channel Spacing (Operating Temperature -20 to +70°C)

MODEL	NOMINAL FREQ. (fo) (MHz)	NUMBER OF POLES	PASSBAND 3dB MIN. (KHz)	RIPPLE MAX. (dB)	INSERTION LOSS MAX. (dB)	STOPBAND MAX. (dB) (KHz)	STOPBAND MAX. (dB) (KHz)	GUARANTEED ATTENUATION (dB) (fo ±KHz)	TERMINATING IMPEDANCE (Ohms/pF)	CASE
ECS-10.7-12A	10.7	2	±6.0	0.5	2.0	18 ±23		35 +300 ~ +1000 40 -200 ~ -1000	2500//2.5	HC-49/U
MF 10.7-12B	10.7	4	±6.0	1.0	2.5	40 ±20		65 +300 ~ +1000 80 -200 ~ -1000	2500//1.5	HC-49/U x 2
MF 10.7-12C	10.7	6	±6.0	2.0	3.0	45 ±14	60 ±20	65 ±20 ~ ±300	2800//1.0	SC-3
MF 10.7-12D	10.7	8	±6.0	2.0	4.0	65 ±14	90 ±20	90 ±20 ~ ±300	2800//1.0	SC-4
ECS-21K12A	21.4	2	±6.0	0.5	2.0	18 ±23		35 +350 ~ +1000 50 -200 ~ -1000	1200//3.0	UM-1
ECS-21K12B	21.4	4	±6.0	1.0	2.5	40 ±20		65 +350 ~ +1000 70 -200 ~ -1000	1200//2.5	UM-1 x 2
ECS-21K12C	21.4	6	±6.0	2.0	3.0	45 ±14	65 ±20	65 ±20 ~ ±300	1200//2.5	SC-1
ECS-21K12D	21.4	8	±6.0	2.0	4.0	65 ±14	90 ±20	90 ±20 ~ ±300	1200//2.5	SC-1

ELECTRICAL CHARACTERISTICS (10.7 and 21.4 MHz)

For 25 KHz Channel Spacing (Operating Temperature -20 to +70°C)

MODEL	NOMINAL FREQ. (fo) (MHz)	NUMBER OF POLES	PASSBAND 3dB MIN. (KHz)	RIPPLE MAX. (dB)	INSERTION LOSS MAX. (dB)	STOPBAND MAX. (dB) (KHz)	STOPBAND MAX. (dB) (KHz)	GUARANTEED ATTENUATION (dB) (fo ±KHz)	TERMINATING IMPEDANCE (Ohms/pF)	CASE
ECS-10.7-15A	10.7	2	±7.5	0.5	2.0	18 ±25		35 +300 ~ +1000 40 -200 ~ -1000	3000//2.0	HC-49/U
ECS-10.7-15B	10.7	4	±7.5	1.0	2.5	40 ±25		55 +300 ~ +1000 80 -200 ~ -1000	3000//2.0	HC-49/U x 2
ECS-10.7-15C	10.7	6	±7.5	2.0	3.0	45 ±17.5	65 ±25	65 ±25 ~ ±300	3000//1.5	SC-3
ECS-10.7-15D	10.7	8	±7.5	2.0	4.0	70 ±17.5	90 ±25	90 ±25 ~ ±300	3000//1.5	SC-4
ECS-10.7-15E	10.7	10	±7.5	2.0	4.5	75 ±15	90 ±20	90 ±20 ~ ±300	3000//1.5	SC-5
ECS-21K15A	21.4	2	±7.5	0.5	1.5	18 ±25		35 +350 ~ +1000 50 -200 ~ -1000	1500//3.0	UM-1
ECS-21K15B	21.4	4	±7.5	1.0	2.0	40 ±25		65 +350 ~ +1000 80 -200 ~ -1000	1500//2.0	UM-1 x 2
ECS-21K15C	21.4	6	±7.5	2.0	2.5	45 ±17.5	65 ±25	65 ±25 ~ ±300	1500//2.0	SC-1
ECS-21K15D	21.4	8	±7.5	2.0	3.0	65 ±17.5	90 ±25	90 ±25 ~ ±300	1500//2.0	SC-1
ECS-21K15E	21.4	10	±7.5	2.0	4.0	75 ±17.5	90 ±20	90 ±25 ~ ±300	1500//2.0	SC-2

For 50 KHz Channel Spacing (Operating Temperature -20 to +70°C)

MODEL	NOMINAL FREQ. (fo) (MHz)	NUMBER OF POLES	PASSBAND 3dB MIN. (KHz)	RIPPLE MAX. (dB)	INSERTION LOSS MAX. (dB)	STOPBAND MAX. (dB) (KHz)	STOPBAND MAX. (dB) (KHz)	GUARANTEED ATTENUATION (dB) (fo ±KHz)	TERMINATING IMPEDANCE (Ohms/pF)	CASE
ECS-10.7-30A	10.7	2	±15	0.5	1.5	15 ±50		30 +300 ~ +1000 40 -300 ~ -1000	5000//0	HC-49/U
ECS-10.7-30B	10.7	4	±15	1.0	2.5	30 ±40		30 ±40 ~ ±300	5500//1.0	HC-49/U x2
ECS-10.7-30C	10.7	6	±15	2.0	3.0	60 ±45		60 ±45 ~ ±300	5500//1.0	SC-3
ECS-10.7-30D	10.7	8	±15	2.0	3.5	70 ±40	90 ±50	90 ±50 ~ ±300	5500//1.0	SC-4
ECS-21K30A	21.4	2	±15	0.5	1.5	15 ±45		35 +350 ~ +1000 45 -300 ~ -1000	1500//1.0	UM-1
ECS-21K30B	21.4	4	±15	1.0	2.0	40 ±50		65 +350 ~ +1000 80 -250 ~ -1000	1800//0.5	UM-1 x 2
ECS-21K30C	21.4	6	±15	2.0	2.5	45 ±35	65 ±50	65 ±50 ~ ±300	2200//0.5	SC-1
ECS-21K30D	21.4	8	±15	2.0	3.5	70 ±35	90 ±50	90 ±50 ~ ±1000	2200//0.5	SC-1

45 MHz Monolithic Crystal Filters (Operating Temperature -20 to +70°C)

MODEL	NOMINAL FREQ. (fo) (MHz)	NUMBER OF POLES	PASSBAND 3dB MIN. (KHz)	RIPPLE MAX. (dB)	INSERTION LOSS MAX. (dB)	STOPBAND MAX. (dB) (KHz)	STOPBAND MAX. (dB) (KHz)	GUARANTEED ATTENUATION (dB) (fo ±KHz)	TERMINATING IMPEDANCE (Ohms/pF)	CASE
ECS-45K7.5A	45.0	2	±3.75	1.0	2.0	10 ±12.5		65 -910	350//10.5	UM-1
ECS-45K7.5B	45.0	4	±3.75	1.0	4.0	30 ±12.5		90 ±910	350//6.5	UM-1 x 2
ECS-45K15A	45.0	2	±7.5	1.0	2.0	15 ±25		75 -910	650//5.0	UM-1
ECS-45K15B	45.0	4	±7.5	1.0	3.0	30 ±25		90 ±910	650//3.0	UM-1 x 2
ECS-45K20A	45.0	2	±10	0.5	2.0	15 ±30		65 -910	910//2.5	UM-1
ECS-45K20B	45.0	4	±10	1.0	3.0	35 ±40		90 ±910	910//2.5	UM-1 x 2
ECS-45K30A	45.0	2	±15	1.0	2.0	15 ±50		70 -910	1200//1.5	UM-1
ECS-45K30B	45.0	4	±15	1.0	3.0	35 ±50		90 ±910	1200//0.7	UM-1 x 2

55 MHz Monolithic Crystal Filters (Operating Temperature -20 to +70°C)

MODEL	NOMINAL FREQ. (fo) (MHz)	NUMBER OF POLES	PASSBAND 3dB MIN. (KHz)	RIPPLE MAX. (dB)	INSERTION LOSS MAX. (dB)	STOPBAND MAX. (dB) (KHz)	STOPBAND MAX. (dB) (KHz)	GUARANTEED ATTENUATION (dB) (fo ±KHz)	TERMINATING IMPEDANCE (Ohms/pF)	CASE
ECS-55K15A	55.0	2	±7.5	1.0	2.0	15 ±25		70 -910	600//3.0	UM-1
ECS-55K15B	55.0	4	±7.5	1.0	3.0	30 ±25		90 ±910	600//1.5	UM-1 x 2
ECS-55K20A	55.0	2	±10	1.0	2.0	15 ±30		75 -910	910//2.5	UM-1
ECS-55K20B	55.0	4	±10	1.0	3.0	25 ±25		90 ±910	910//1.0	UM-1 x 2
ECS-55K30A	55.0	2	±15	1.0	2.0	15 ±50		70 -910	1200//1.5	UM-1
ECS-55K30B	55.0	4	±15	1.0	3.0	30 ±50		90 ±910	1200//0.7	UM-1 x 2
ECS-55K32A	55.0	2	±16	0.5	2.5	4 ±29.5		65 -910	1250//1.3	UM-1
ECS-55K32B	55.0	4	±16	1.0	5.0	30 ±52		80 ±910	1250//0.5	UM-1 x 2

70 MHz & 90 MHz Monolithic Crystal Filters (Operating Temperature -20 to +70°C)

MODEL	NOMINAL FREQ. (fo) (MHz)	NUMBER OF POLES	PASSBAND 3dB MIN. (KHz)	RIPPLE MAX. (dB)	INSERTION LOSS MAX. (dB)	STOPBAND MAX. (dB) (KHz)	STOPBAND MAX. (dB) (KHz)	GUARANTEED ATTENUATION (dB) (fo ±KHz)	TERMINATING IMPEDANCE (Ohms/pF)	CASE
ECS-70K15A	70.0	2	±7.5	1.0	2.5	15 ±25		35 -910	2000//1.0	UM-1
ECS-70K15B	70.0	4	±7.5	1.0	4.0	40 ±35		70 ±910	2000//1.0	UM-1 x 2
ECS-70K20A	70.0	2	±10	1.0	2.5	15 ±28		35 -910	2500//1.0	UM-1
ECS-70K20B	70.0	4	±10	1.0	4.0	35 ±40		70 ±910	2500//1.0	UM-1 x 2
ECS-90M20A	90.0	2	±10	1.0	2.5	15 ±30		35 -910	2500//1.0	UM-1
ECS-90M20B	90.0	4	±10	1.0	4.0	30 ±30		70 ±910	2500//1.0	UM-1 x 2

DIMENSIONS AND ELECTRICAL DIAGRAMS (mm)

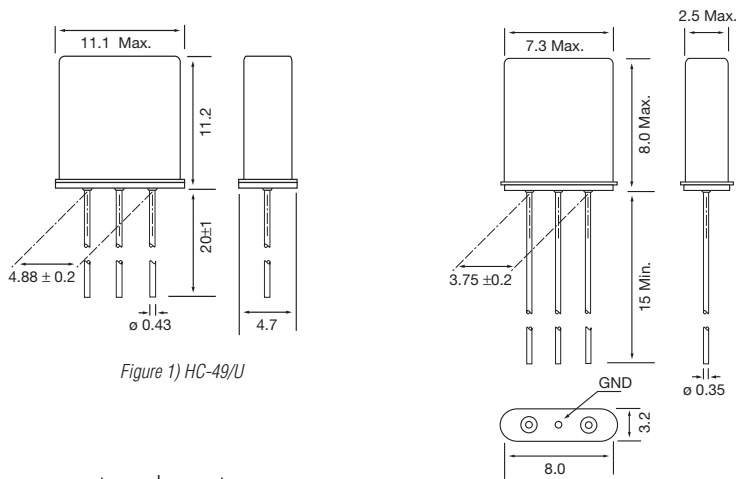

Figure 1) HC-49/U

Figure 2) UM-1

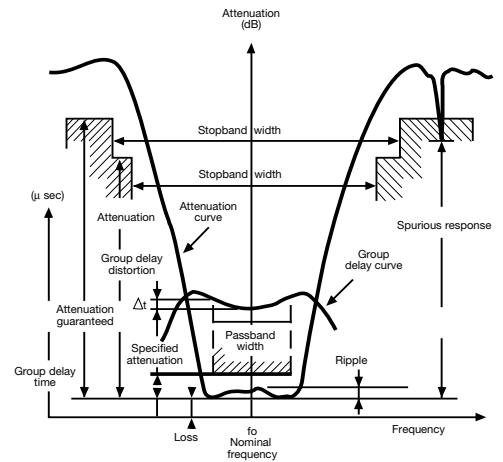

Figure 3) MCF Characteristics Curve

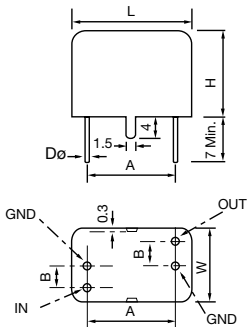

Figure 4) SC Pkg with Dimensional Chart

CASE	DIMENSIONS (mm)					
	L	W	H	A	B	D
SC-1	11	8.5	11.5	7.4	2.0	0.30
SC-2	13.4	8.5	11.5	9.8	2.0	0.30
SC-3	15	12.0	15.0	9.0	2.5	0.43
SC-4	18.5	12.0	15.0	13.4	2.5	0.43
SC-5	23.0	12.0	15.0	17.8	2.5	0.43

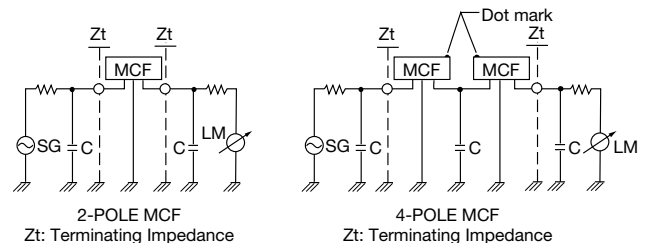
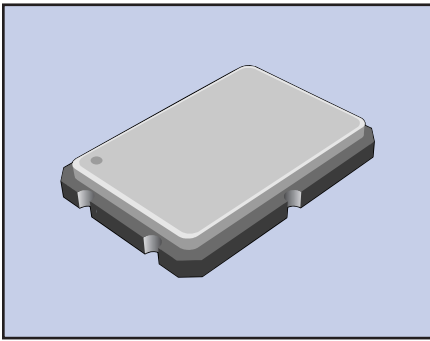

Figure 5) MCF Test Circuits



ECS delivers pure filtering versatility with the ECS-96SMF Series monolithic crystal filter. This low profile SMD filter addresses a broad range of applications including wide/narrow band filters for mobile, UHF and cordless telephone applications.

FEATURES

- Low profile of 1.5 mm maximum height
- Industry standard footprint
- Sharp cut-off characteristics
- Long term stability
- Tape & Reel (1,000 pcs)

PART NUMBERING GUIDE

PART NUMBER	FREQUENCY
ECS-96SMF21A15	21.40000 MHz
ECS-96SMF29A20	29.25000 MHz
ECS-96SMF45A30	45.00000 MHz
ECS-96SMF109A24	109.65000 MHz

OPERATING CONDITIONS/ELECTRICAL CHARACTERISTICS

PARAMETERS	ECS-96SMF21A15	ECS-96SMF29A20	ECS-96SMF45A30	ECS-96SMF109A24	UNITS
NOMINAL FREQUENCY	21.40000	29.25000	45.00000	109.65000	MHz
OSCILLATION MODE	Fundamental	Fundamental	Fundamental	3rd Overtone	
3 db PASSBAND WIDTH	±7.5KHz min.	±10KHz min.	±15KHz min.	±12KHz min.	KHz
STOPBAND WIDTH	±25KHz max./10db	±25KHz max./10db	±60KHz max./15db	±60KHz max./18db	KHz/db
RIPPLE	1.0db max.	1.0db max.	1.0db max.	1.0db max.	db
INSERTION LOSS	2.5db max.	1.5db max.	3.0db max.	3.0db max.	db
ATTENUATION GUAR. (fo-910KHz)	65db min.	70db min.	70db min.	65db min.	db
TERMINATING IMPEDANCE	1500Ω//2.5pF	1800Ω//1.5pF	1200Ω//1.8pF	1500Ω//1.2pF	Ω//pF
OPERATING TEMP. RANGE	-30 ~ +85	-30 ~ +85	-30 ~ +85	-30 ~ +85	°C
NUMBER OF POLES	2	2	2	2	

PACKAGE DIMENSIONS (mm)

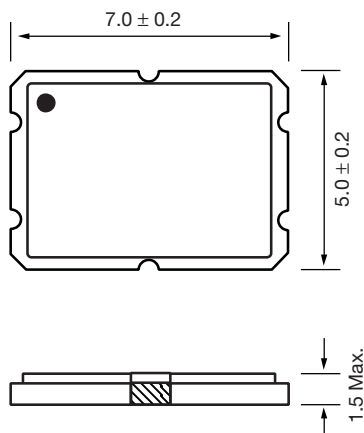

Figure 1) ECS-96SMF - Top and Side views

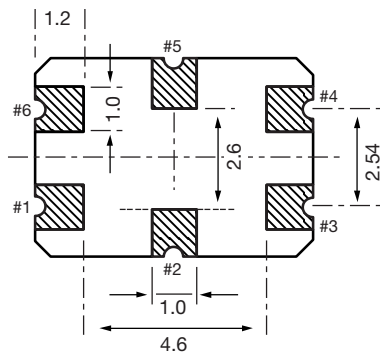

Figure 2) ECS-96SMF Pad Layout - Bottom view

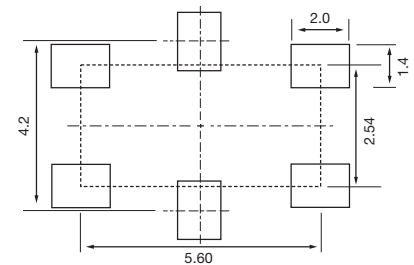
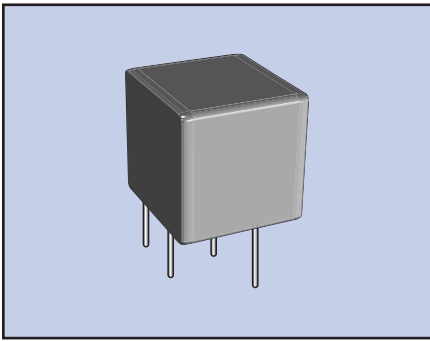

Figure 3) ECS-96SMF Land Pattern

PIN CONNECTIONS	
#1	IN/OUT
#2	GND
#3	GND
#4	OUT/IN
#5	GND
#6	GND



Ultra small size high selectivity type ceramic filter for communication use.

FEATURES

- Ultra small size
- 6.5 mm profile
- Bandwidths from 4KHz to 30KHz available
- High selectivity
- 4 elements

OPERATING CONDITIONS/ELECTRICAL CHARACTERISTICS

PART NUMBER	CENTER FREQUENCY (KHz)	INSERTION LOSS (dB) MAX.	PASS BAND RIPPLE (dB) MAX.	6 dB BANDWIDTH (KHz) MIN.	40 dB BANDWIDTH (dB) MAX.	STOP BAND ATT. ±100KHZ (dB) MIN.	INPUT / OUTPUT IMPEDANCE (Ω)
LTM450BU	450 ±2.0	4	2	±15	±30	27	1500
LTM450CU	450 ±2.0	4	2	±12.5	±24	27	1500
LTM450DU	450 ±1.5	4	2	±10	±20	27	1500
LTM450EU	450 ±1.5	6	2	±7.5	±15	27	1500
LTM450FU	450 ±1.5	6	2	±6	±12.5	27	2000
LTM450GU	450 ±1.0	6	2	±4.5	±10	25	2000
LTM450HU	450 ±1.0	6	2	±3	±9	25	2000
LTM450IU	450 ±1.0	6	2	±2	±7.5	25	2000
LTM450HTU	450 ±1.0	6	2	±3	±9	35	2000
LTM450ITU	450 ±1.0	6	2	±2	±7.5	35	2000

PACKAGE DIMENSIONS (mm)

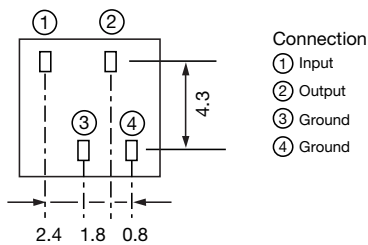
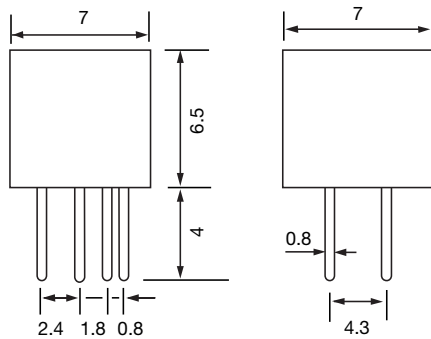

Figure 1) LTM450U – Front, Side and Bottom views

Note: To avoid potential problems, connect the output to an IF amplifier through a DC cut capacitor.
 Avoid applying a direct current to output end of the ceramic filters (between ③ and ①②).

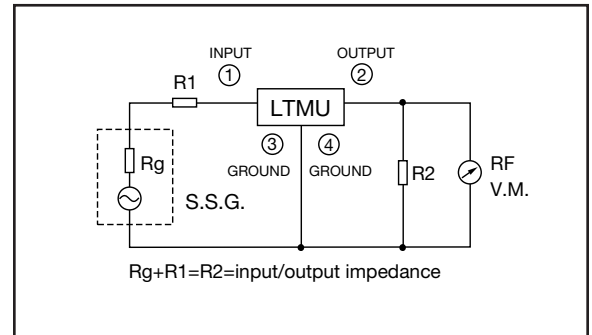

Figure 2) LTM450U – Measuring Circuit

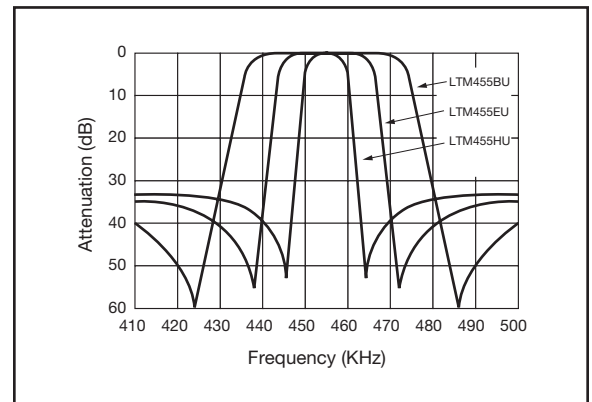
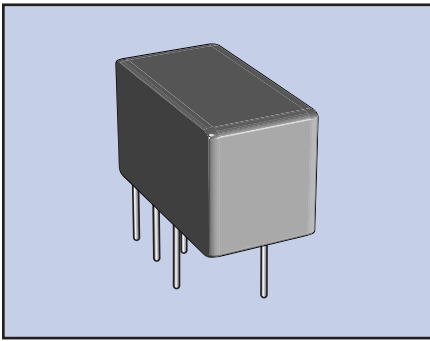

Figure 3) LTM4550U – Characteristics



Ultra small size high selectivity type ceramic filter for communication use.

FEATURES

- Ultra small size
- 6.3 mm profile
- Broad bandwidth
- High selectivity
- 6 elements

OPERATING CONDITIONS/ELECTRICAL CHARACTERISTICS

PART NUMBER	CENTER FREQUENCY (KHz)	INSERTION LOSS (dB) MAX.	PASS BAND RIPPLE (dB) MAX.	6 dB BANDWIDTH (KHz) MIN.	50 dB BANDWIDTH (dB) MAX.	STOP BAND ATT. ±100KHZ (dB) MIN.	INPUT / OUTPUT IMPEDANCE (Ω)
LTM450BW	450 ±2.0	4	2	±15	±30	45	1500
LTM450CW	450 ±2.0	4	2	±12.5	±24	45	1500
LTM450DW	450 ±1.5	4	2	±10	±20	45	1500
LTM450EW	450 ±1.5	6	2	±7.5	±15	45	1500
LTM450FW	450 ±1.5	6	2	±6	±12.5	45	2000
LTM450GW	450 ±1.5	6	2	±4.5	±10	45	2000
LTM450HW	450 ±1.0	6	2	±3	±9	55	2000
LTM450IW	450 ±1.0	6	2	±2	±7.5	55	2000
LTM450HTW	450 ±1.0	6	2	±3	±9	60	2000
LTM450ITW	450 ±1.0	6	2	±2	±7.5	60	2000

PACKAGE DIMENSIONS (mm)

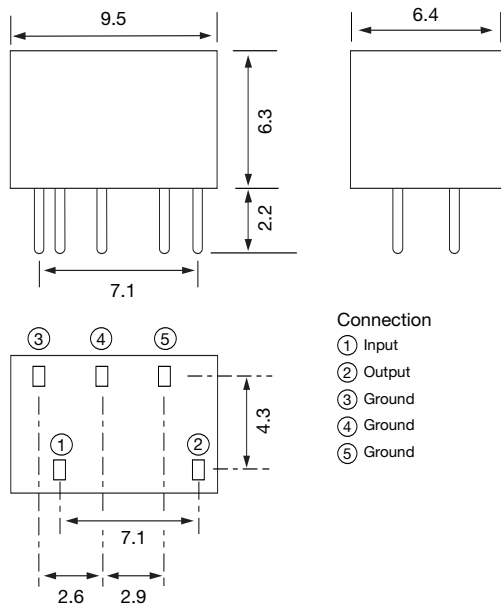

Figure 1) LTM450W – Front, Side and Bottom views

Note: To avoid potential problems, connect the output to an IF amplifier through a DC cut capacitor.
Avoid applying a direct current to output end of the ceramic filters (between ⑤ and ②③④).

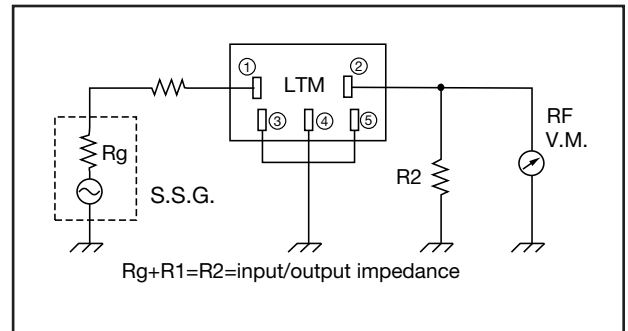

Figure 2) LTM450W – Measuring Circuit

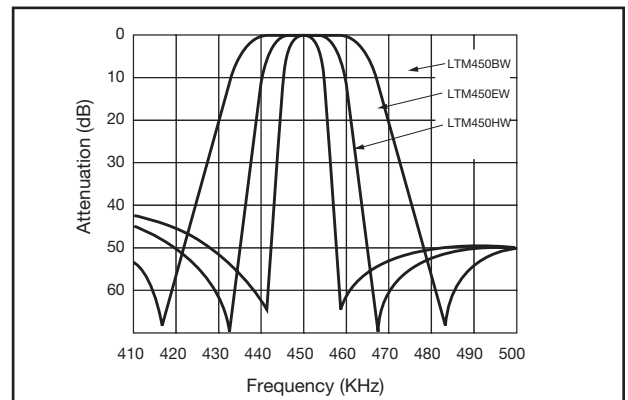
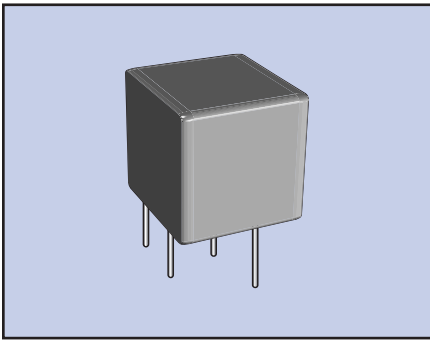

Figure 3) LTM450W – Characteristics



Ultra small size high selectivity type ceramic filter for communication use.

FEATURES

- Ultra small size
- 6.5 mm profile
- Bandwidths from 4KHz to 30KHz available
- High selectivity
- 4 elements

OPERATING CONDITIONS/ELECTRICAL CHARACTERISTICS

PART NUMBER	CENTER FREQUENCY (KHz)	INSERTION LOSS (dB) MAX.	PASS BAND RIPPLE (dB) MAX.	6 dB BANDWIDTH (KHz) MIN.	40 dB BANDWIDTH (dB) MAX.	STOP BAND ATT. ±100KHZ (dB) MIN.	INPUT / OUTPUT IMPEDANCE (Ω)
LTM455BU	455 ±2.0	4	2	±15	±30	27	1500
LTM455CU	455 ±2.0	4	2	±12.5	±24	27	1500
LTM455DU	455 ±1.5	4	2	±10	±20	27	1500
LTM455EU	455 ±1.5	6	2	±7.5	±15	27	1500
LTM455FU	455 ±1.5	6	2	±6	±12.5	27	2000
LTM455GU	455 ±1.0	6	2	±4.5	±10	25	2000
LTM455HU	455 ±1.0	6	2	±3	±9	25	2000
LTM455IU	455 ±1.0	6	2	±2	±7.5	25	2000
LTM455HTU	455 ±1.0	6	2	±3	±9	35	2000
LTM455ITU	455 ±1.0	6	2	±2	±7.5	35	2000

PACKAGE DIMENSIONS (mm)

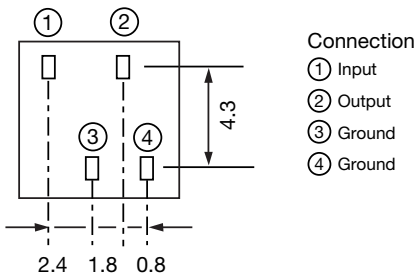
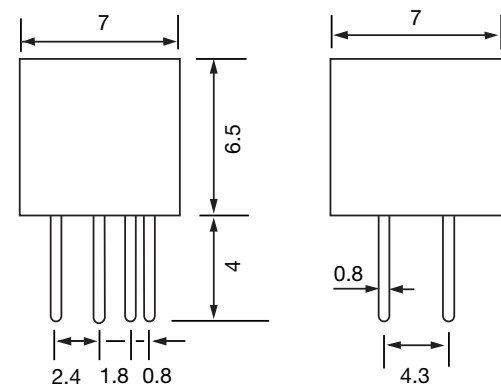

Figure 1) LTM455U – Front, Side and Bottom views

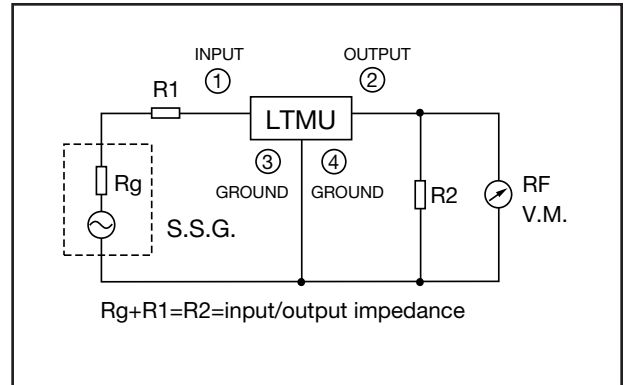

Figure 2) LTM455U – Measuring Circuit

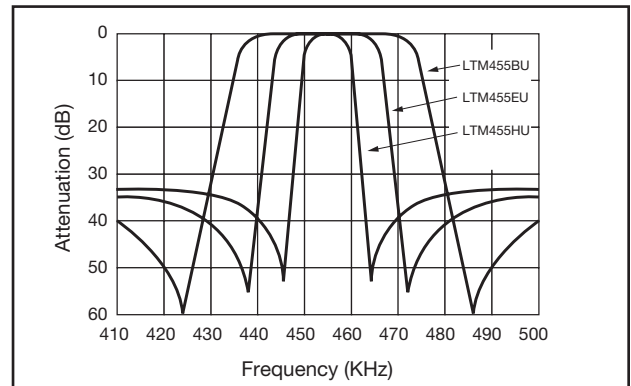
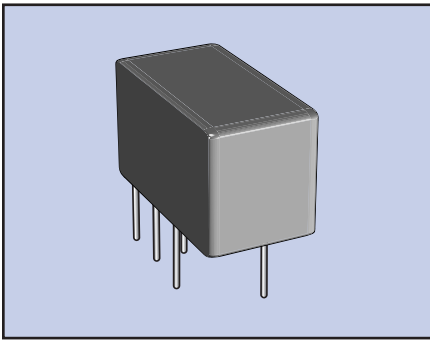

Figure 3) LTM455U – Characteristics

Note: To avoid potential problems, connect the output to an IF amplifier through a DC cut capacitor.
Avoid applying a direct current to output end of the ceramic filters (between ③ and ①②).



Ultra small size high selectivity type ceramic filter for communication use.

FEATURES

- Ultra small size
- 6.3 mm profile
- Broad bandwidth
- High selectivity
- 6 elements

OPERATING CONDITIONS/ELECTRICAL CHARACTERISTICS

PART NUMBER	CENTER FREQUENCY (KHz)	INSERTION LOSS (dB) MAX.	PASS BAND RIPPLE (dB) MAX.	6 dB BANDWIDTH (KHz) MIN.	50 dB BANDWIDTH (dB) MAX.	STOP BAND ATT. ±100KHZ (dB) MIN.	INPUT / OUTPUT IMPEDANCE (Ω)
LTM455BW	455 ±2.0	4	2	±15	±30	45	1500
LTM455CW	455 ±2.0	4	2	±12.5	±24	45	1500
LTM455DW	455 ±1.5	4	2	±10	±20	45	1500
LTM455EW	455 ±1.5	6	2	±7.5	±15	45	1500
LTM455FW	455 ±1.5	6	2	±6	±12.5	45	2000
LTM455GW	455 ±1.5	6	2	±4.5	±10	45	2000
LTM455HW	455 ±1.0	6	2	±3	±9	45	2000
LTM455IW	455 ±1.0	6	2	±2	±7.5	45	2000
LTM455HTW	455 ±1.0	6	2	±3	±9	60	2000
LTM455ITW	455 ±1.0	6	2	±2	±7.5	60	2000

PACKAGE DIMENSIONS (mm)

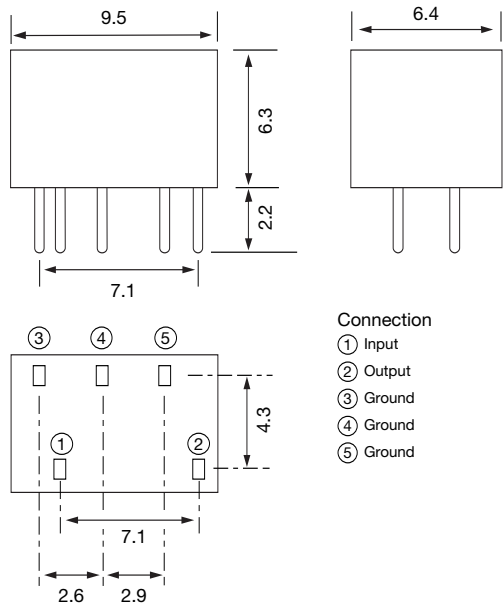

Figure 1) LTM455W – Front, Side and Bottom views

Note: To avoid potential problems, connect the output to an IF amplifier through a DC cut capacitor. Avoid applying a direct current to output end of the ceramic filters (between ⑤ and ②③④).

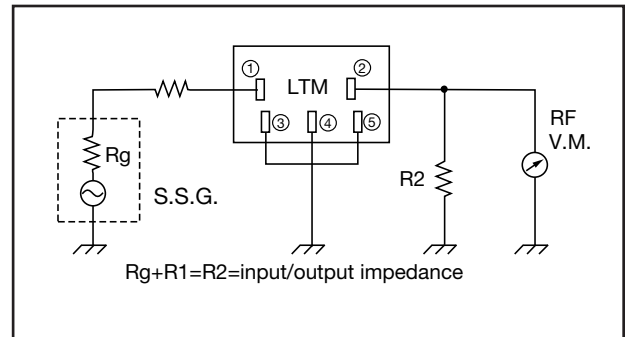

Figure 2) LTM455W – Measuring Circuit

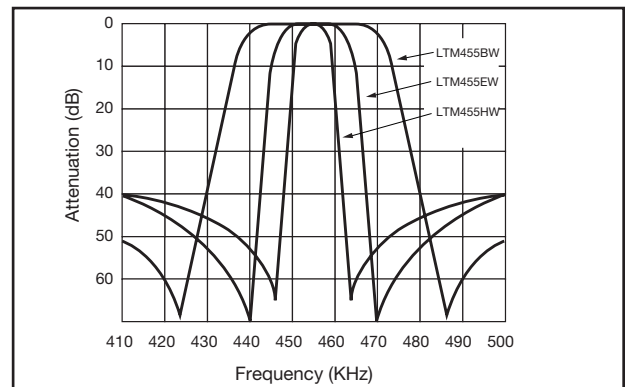
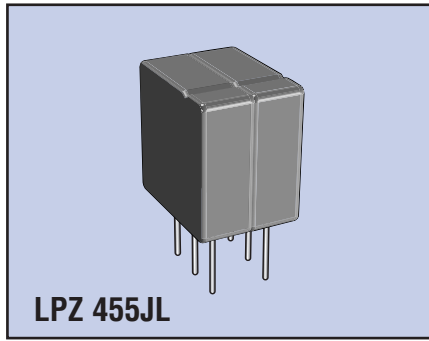
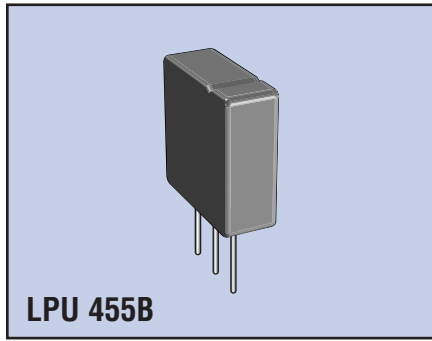

Figure 3) LTM455W – Characteristics



FEATURES

- AM use
- Excellent matching characteristics for IFT

OPERATING CONDITIONS/ELECTRICAL CHARACTERISTICS

PART NUMBER	3dB BANDWIDTH (KHz)	SELECTIVITY -9 KHZ OFF (dB) MIN.	SELECTIVITY +9 KHZ OFF (dB) MIN.	INSERTION LOSS (dB) MAX.	COMPOSITION
LPU455B - (connected with IFT)	10 ±3	5 (7.5)	3 (5.5)	5 (3)	1 Element with IFT
LPZ455JL - (connected with IFT)	5.5 ±1	18 (20)	18 (20)	7 (3.5)	2 Elements Direct Coupling Type

- Center frequency (fo) is available in a range of 450 to 470KHz. The standard tolerance of fo is ±2KHz. For synthesizers and digital indicators, ±1KHz tolerance is also available.
 - The LPZ455JL series, with its two directly coupled elements, has a high degree of selectivity. The series features excellent matching characteristics for IFT.
- () = Typical values

PACKAGE DIMENSIONS (mm)

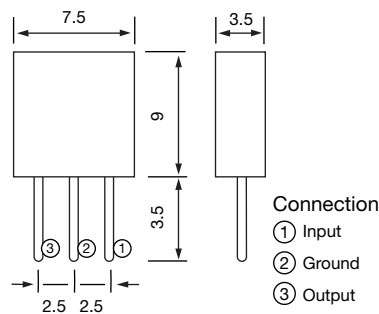

Figure 1) LPU455B – Front and Side views

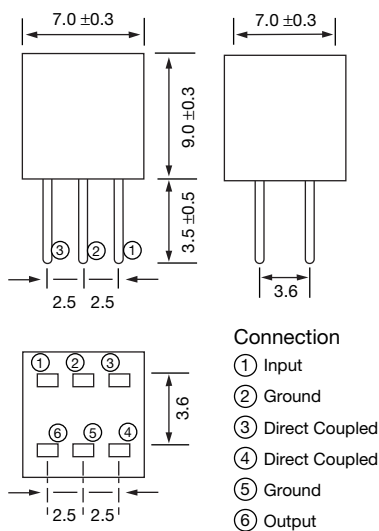

Figure 2) LPZ455JL – Front, Side and Bottom views

ITEM \ TYPE	LPU □□□B			LPZ □□□JL		
WINDING SPECIFICATIONS	①—②	②—③	④—⑥	①—②	②—③	④—⑥
	70 T	115 T	7 T	68 T	84 T	14 T
UNLOADED Qu	105			90		
TUNING CAPACITY	180pF			180pF		

Figure 3) Recommended IFT Specifications

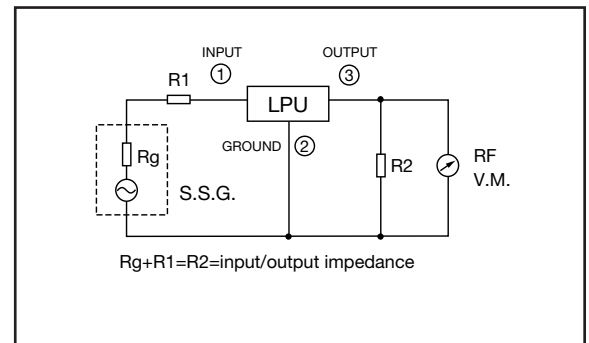

Figure 4) LPU Series – Measuring Circuit

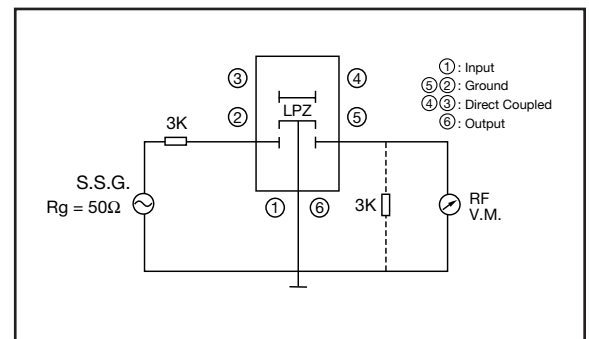
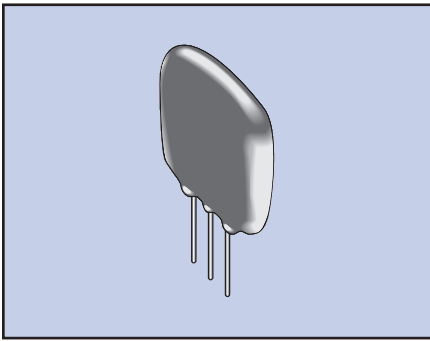

Figure 5) LPZ Series – Measuring Circuit



The LTE Series ceramic filter is used for TV 4.5 / 5.5 / 6.0 / 6.5 MHz (TV SIF stage use).

FEATURES

- Wide bandwidth
- Low insertion loss
- Excellent spurious suppression characteristics
- TV SIF stage use

OPERATING CONDITIONS/ELECTRICAL CHARACTERISTICS

PART NUMBER	3dB BAND WIDTH (KHz) MIN.	20dB BAND WIDTH (KHz) MAX.	INSERTION LOSS (dB) MAX.	SPURIOUS RESPONSE (dB) MIN./FREQ.	INPUT / OUTPUT IMPEDANCE (Ω)
LTE4.5MB	±60(±105)	530(420)	6(4)	20(4.5 +0.8 -1.0 MHz)	1000
LTE5.5MB	±75(±120)	550(470)	6(3)	25(5.5±1.0 MHz)	600
LTE6.0MB	±80(±130)	600(500)	6(2.5)	25(6.0 ±1.0 MHz)	470
LTE6.5MB	±80(±130)	630(530)	6(2.5)	25(6.5 ±1.0 MHz)	470

() = Typical values

PACKAGE DIMENSIONS (mm)

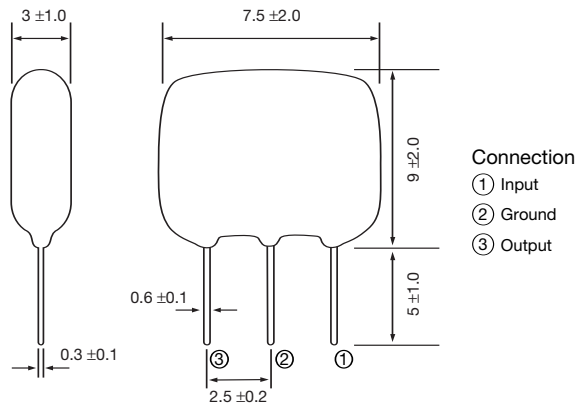

Figure 1) LTE Series – Front and Side views

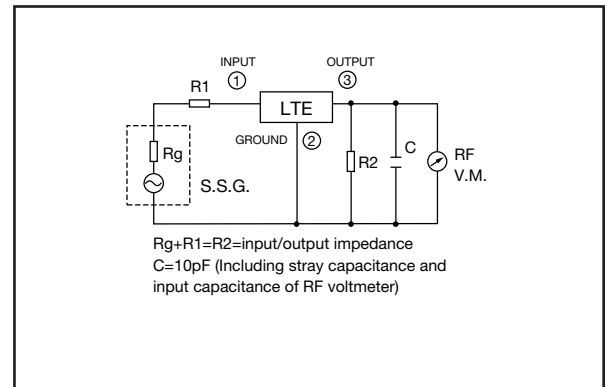

Figure 2) LTE Series – Measuring Circuit

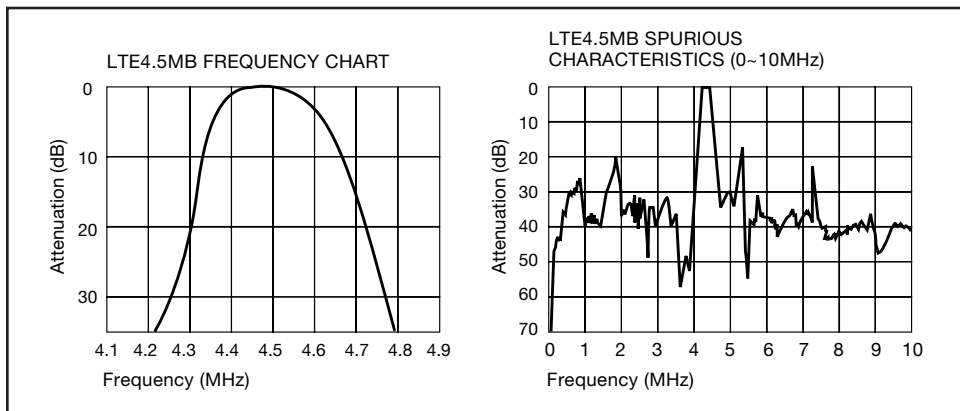
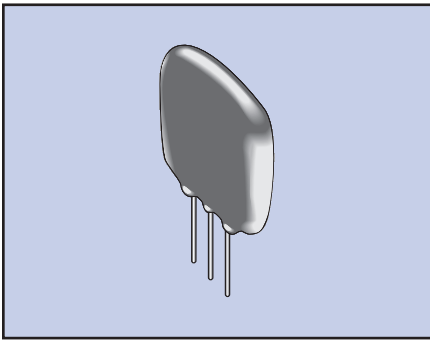

Figure 3) LTE Series – Characteristics



The XT Series is a ceramic trap for TV 4.5 / 5.5 / 6.0 / 6.5 MHz. (TV SIF stage use)

FEATURES

- Wide bandwidth
- Low insertion loss
- Excellent spurious suppression characteristics
- TV SIF stage use

OPERATING CONDITIONS/ELECTRICAL CHARACTERISTICS

PART NUMBER	TRAP ATTENUATION (AT NORMAL CENTER FREQUENCY) (dB) MIN.	20 dB Band Width (KHz) MIN.	30 dB BAND WIDTH (KHz) MIN.
XT4.5MB	35(45)	-	50(80)
XT5.5MB	35(45)	-	50(80)
XT6.0MB	35(45)	-	70(120)
XT6.5MB	35(45)	-	70(120)

• The level @ 1 MHz shall be the (0 dB) reference. () = Typical values

PACKAGE DIMENSIONS (mm)

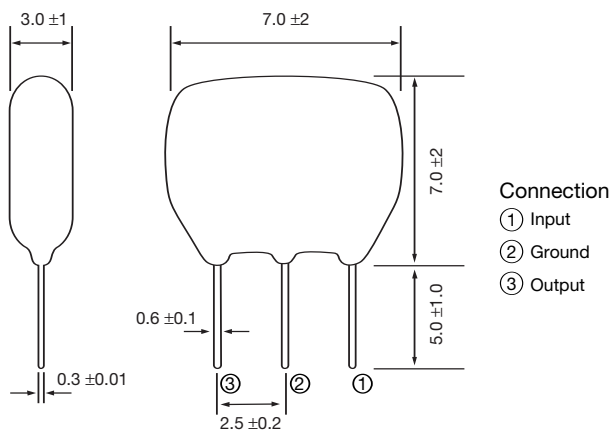

Figure 1) XT Series - Front and Side views

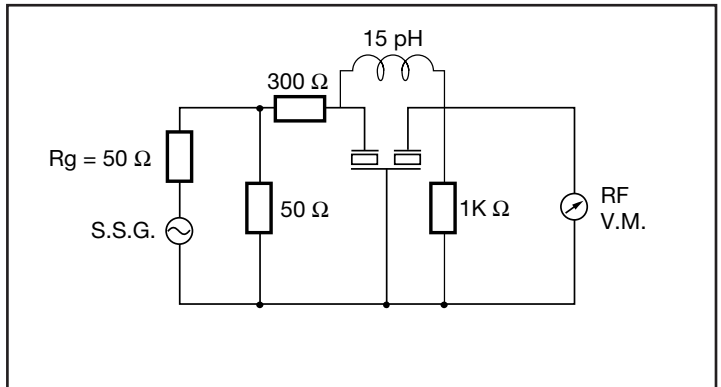

Figure 2) XT Series - Measuring Circuit

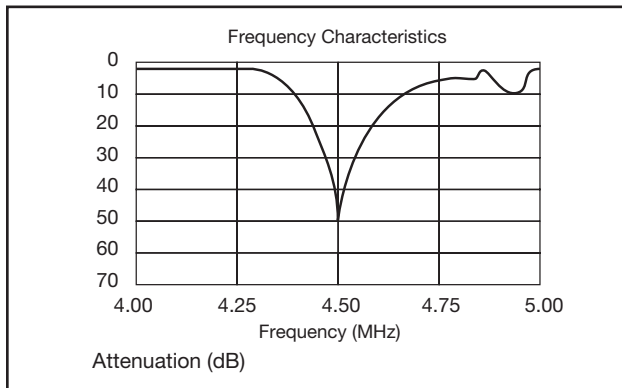
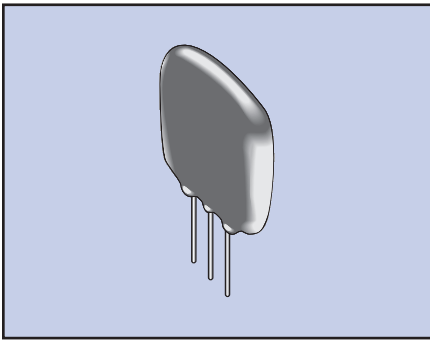

Figure 3) XT Series - Characteristics



The L10.7 Series ceramic filter is for FM use.

FEATURES

- FM use

OPERATING CONDITIONS/ELECTRICAL CHARACTERISTICS

PART NUMBER	3dB BAND WIDTH (KHz) MIN.	20dB BAND WIDTH (KHz) MAX.	INSERTION LOSS (dB) MAX.	SPURIOUS (dB) MIN. (9-12 MHz)
L10.7 MA20 □	330 ±50	680	6	30
L10.7 MA5 □	280 ±50	650	6	30
L10.7 MS2 □	230 ±50	600	6	40
L10.7 MS3 □	180 ±50	520	7	40
L10.7 MJ □	150 ±50	400	10	35
L10.7 MH □	110 ±50	350	10	30

() = Typical values, input/output impedance: 330 Ohms, FO tolerance ±30 KHz.

□ = Indicator (FO), Complete part number to include indicator i.e. L10.7 MA5C (C=10.73 MHz)

COLOR SPECIFICATIONS

SPECIFICATION (Fo) MHz	10.64	10.67	10.7	10.73	10.76
INDICATOR	D	B	A	C	E
COLOR	Black	Blue	Red	Orange	White

PACKAGE DIMENSIONS (mm)

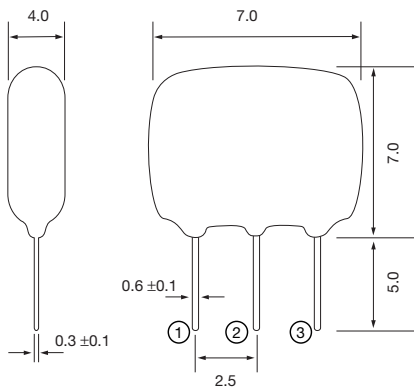

Figure 1) L10.7 - Front & Side views

- Connection
- ① In/Out
 - ② Ground
 - ③ Out/In

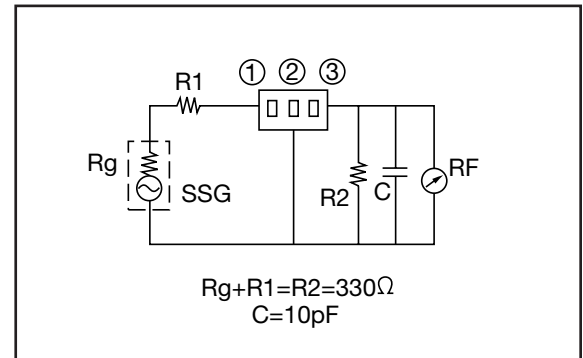
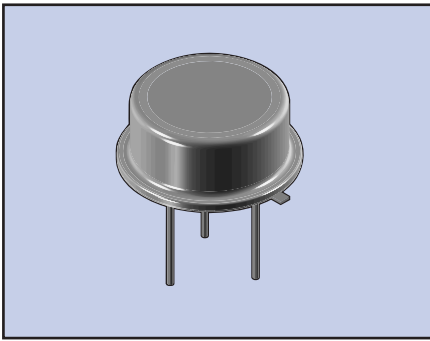

Figure 2) Test Circuit



The ECS-DR1 Series are 1-port SAW (Surface Acoustic Wave) resonators in a thru-hole TO39-3A package. They offer a fundamental mode, quartz frequency and are ideal for remote control and wireless security transmitters.

FEATURES

- Quartz Stability
- Ideal for wireless security and remote control applications

PART NUMBERING GUIDE

ECS SERIES	FREQUENCY (479.50 MHz)
ECS-D	479.5

OPERATING CONDITIONS/ELECTRICAL CHARACTERISTICS

PARAMETERS	CONDITIONS	ECS-D479.5B			ECS-D480A			UNITS
		MIN	TYP	MAX	MIN	TYP	MAX	
CENTER FREQUENCY		478.0	479.5	481.0	479.0	480.0	481.0	MHz
INSERTION LOSS	@ F ₀			23		19.5	21	dB
3 dB PASS BAND		25.7	26.7	27.7	16.6	17.6	18.6	MHz
SPURIOUS RESPONSE	0 ~ 750MHz	30						dB
RELATIVE ATTENUATION	@ 471.0 MHz					3.4	5.4	dB
	@ 489.0 MHz					3.0	5.4	dB
	430 ~ 461 MHz				38.0	50.0		dB
	499 ~ 530 MHz				38.0	45.0		dB
AMPLITUDE RIPPLE	476.0 ~ 484.0 MHz					0.3	0.6	dB
GROUP DELAY	480.0 MHz					281.0		nS
GROUP DELAY RIPPLE	471.5 ~ 488.5 MHz					11.5	18.0	nS
FREQUENCY STABILITY	-25 ~ +85°C		-86			-86		PPM/°C
INSULATION RESISTANCE	10 V DC	1						MΩ
TERMINATING IMPEDANCE	Input		60Ω/4.8 pF			70Ω/3.7 pF		
	Output		260Ω/3.1 pF			280Ω/2.5 pF		
OPERATING TEMPERATURE		-25		+85	-25		+85	°C
STORAGE TEMPERATURE		-40		+85	-40		+85	°C

PACKAGE DIMENSIONS (mm)

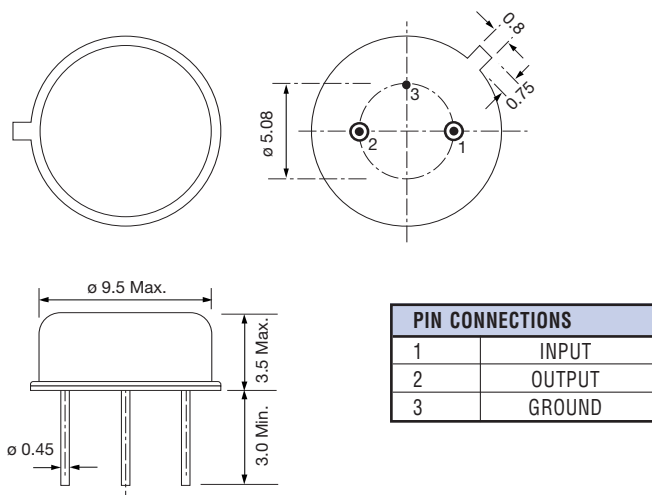
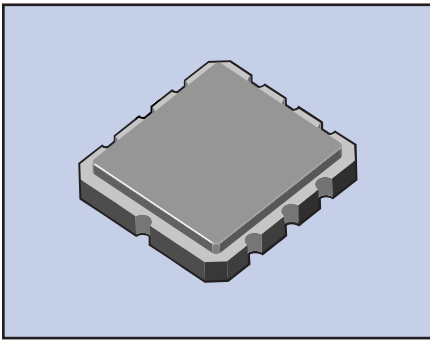

Figure 1) Top Side and Bottom views



OPERATING CONDITIONS/ELECTRICAL CHARACTERISTICS

PARAMETERS	CONDITIONS	ECS-DSF-400.0A-51			ECS-DSF-947.5B-21			UNITS
		MIN	TYP	MAX	MIN	TYP	MAX	
CENTER FREQUENCY			400.0			947.5		MHz
INSERTION LOSS	935 ~ 960 MHz			6			3.3	dB
PASS BAND			±83 KHz		25.0			MHz
PASS BAND RIPPLE	935 ~ 960 MHz						1.4	dB
RIPPLE DEVIATION	Pass Band			2.0				dB
GROUP DELAY RIPPLE				1.0				µsec
STOP BAND	50 ~ 398.5 MHz	35.0						dB
	398.5 ~ 399.2 MHz	20.0						dB
	399.2 ~ 399.4 MHz	10.0						dB
	399.4 ~ 399.6 MHz	7.0						dB
	400.4 ~ 400.6 MHz	7.0						dB
	400.6 ~ 400.8 MHz	10.0						dB
	400.8 ~ 401.5 MHz	20.0						dB
401.5 ~ 500 MHz	35.0						dB	
TERMINATING IMPEDANCE			600Ω/90 nH					
RELATIVE ATTENUATION	DC ~ 871 MHz				50.0			dB
	890 ~ 915 MHz				30.0			dB
	980 ~ 1025 MHz				25.0			dB
	1025 ~ 1705 MHz				45.0			dB
	1705 ~ 3000 MHz				25.0			dB
PASSBAND VSWR	935 ~ 960 MHz						2:1	
OPERATING TEMPERATURE		-40		+85	-30		+80	°C
STORAGE TEMPERATURE		-40		+85	-40		+85	°C

PACKAGE DIMENSIONS (mm)

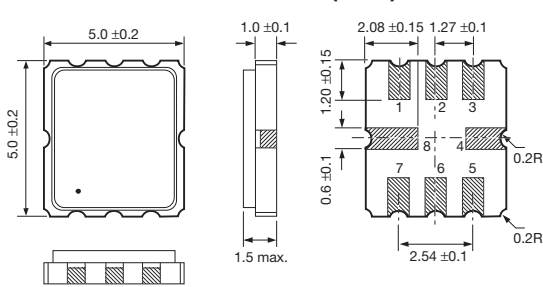

Figure 1) DSF400 Top, Side, Bottom and End views

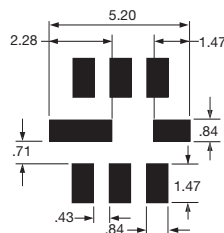

Figure 2) DSF-400 Suggested Land Pattern

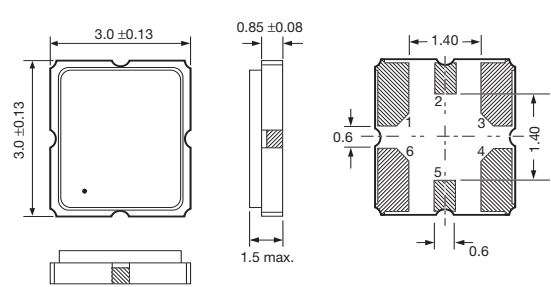
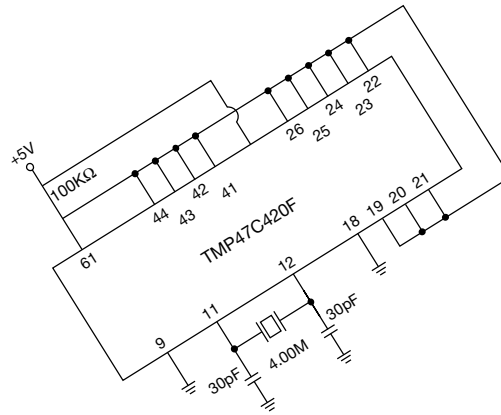
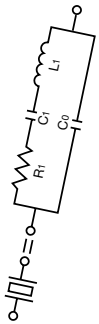

Figure 3) DSF947.5 Top, Side, Bottom and End views

DSF-400 PAD CONNECTIONS	
#1	Input
#2	Ground
#3	Ground
#4	Ground
#5	Output
#6	Ground
#7	Coupling
#8	Ground

DSF-947.5 PAD CONNECTIONS	
#1	Ground
#2	Signal
#3	Ground
#4	Ground
#5	Signal
#6	Ground



TECHNICAL REFERENCES

Additional product information that includes design parameters, design considerations, specific product application notes, test procedures, and functioning principles.

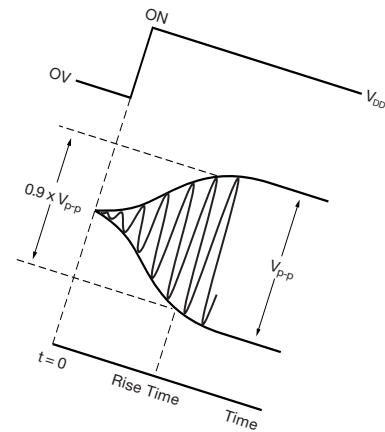
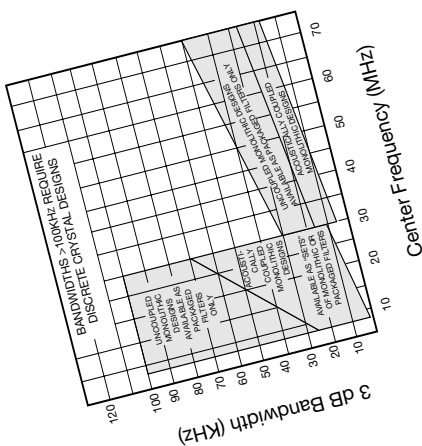

Series vs. Parallel: “Series” resonant crystals are intended for use in circuits which contain no reactive components in the oscillator feedback loop. “Parallel” resonant crystals are intended for use in circuits which contain reactive components (usually capacitors) in the oscillator feedback loop. Such circuits depend on the combination of the reactive components and the crystal to accomplish the phase shift necessary to start and maintain oscillation at the specified frequency. Basic depictions of two such circuits are shown below.

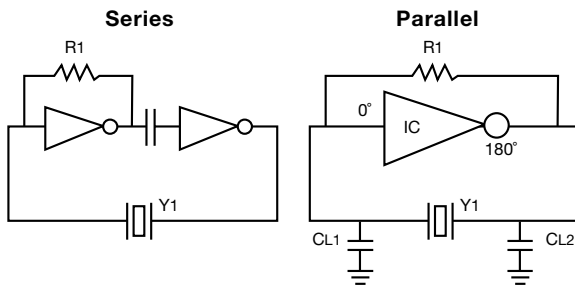

Figure A) Depictions of Series and Parallel Resonant Circuits

Load Capacitance: This refers to capacitance external to the crystal, contained within the feedback loop of the oscillator circuit. If the application requires a “parallel” resonant crystal, the value of load capacitance must be specified. If the application requires a “series” resonant crystal, load capacitance is not a factor and need not be specified. Load capacitance is the amount of capacitance measured or computed across the crystal terminals on the PCB.

Frequency Tolerance: Frequency tolerance refers to the allowable deviation from nominal, in parts per million (PPM), at a specific temperature, usually +25°C.

Frequency Stability: Frequency stability refers to the allowable deviation, in parts per million (PPM), over a specified temperature range. Deviation is referenced to the measured frequency at +25°C.

Aging: Aging refers to the cumulative change in frequency experienced by a crystal unit over time. The rate of frequency change is fastest during the first 45 days of operation. The most common factors affecting aging include drive level, internal contamination, crystal surface change, ambient temperature, wire fatigue and frictional wear. All these problems can be minimized by proper circuit design which allows for low operating temperatures, minimum drive levels and static pre-aging.

Pullability: Pullability refers to the change in frequency of a crystal unit, either from the natural resonant frequency (f_r) to a load resonant frequency (f_L), or from one load resonant frequency to another. See Figure C. The amount of pullability exhibited by a given crystal unit at a given value of load capacitance is a function of the shunt capacitance (C_0) and the motional capacitance (C_1) of the crystal unit.

If pullability is a factor in design, collaboration with our engineers is advisable; bandwidth can be controlled to some extent, during fabrication, by varying the crystal parameters. An approximation of the pulling limits for standard crystals can be obtained from the following formula:

$$\Delta f = 0.5 f_s \left(\frac{C_1}{C_0 + C_L} \right)$$

The exact limits also depend upon the Q of the crystal as well as associated stray capacitances. Pullability can be approximately doubled by modified crystal fabrication and by adding capacitance or inductance external to the crystal. If the C_0 and C_1 are known then the pulling in ppm between two capacitances can be obtained using the following formula.

$$\text{ppm} = \frac{C_1 (C_{L2} - C_{L1}) 10^6}{2 (C_0 + C_{L2})(C_0 + C_{L1})}$$

e.g. $C_1 = 0.020 \text{ pF}$ $C_{L1} = 20 \text{ pF}$
 $C_0 = 4.5 \text{ pF}$ $C_{L2} = 30 \text{ pF}$

$$\text{ppm} = \frac{.02(30 - 20)10^6}{2(4.5 + 30)(4.5 + 20)} = 118.3082 \text{ ppm}$$

To obtain AVERAGE pulling per pF about a known load capacitance use the following formula.

$$\text{ppm} = \frac{C_1 \times 10^6}{2(C_0 + C_L)^2}$$

e.g. Using figures as above and 30 pF C_L

$$\text{ppm/pF} = \frac{.02 \times 10^6}{2(4.5 + 30)^2} = 8.4016 \text{ ppm/pF average.}$$

Equivalent Circuit: The equivalent circuit, shown in Figure B is an electrical depiction of the quartz crystal unit when operating at a frequency of natural resonance. The C_0 , or shunt capacitance, represents the capacitance of the crystal electrodes plus the capacitance of the holder and leads. R_1 , C_1 , and L_1 compose the “motional arm” of the crystal and are referred to as the motional parameters. The motional inductance (L_1), represents the vibrating mass of the crystal unit. The motional capacitance (C_1), represents the elasticity of the quartz and the resistance (R_1), represents bulk losses occurring within the quartz.

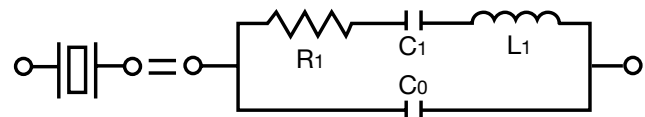

Figure B) Equivalent Circuit

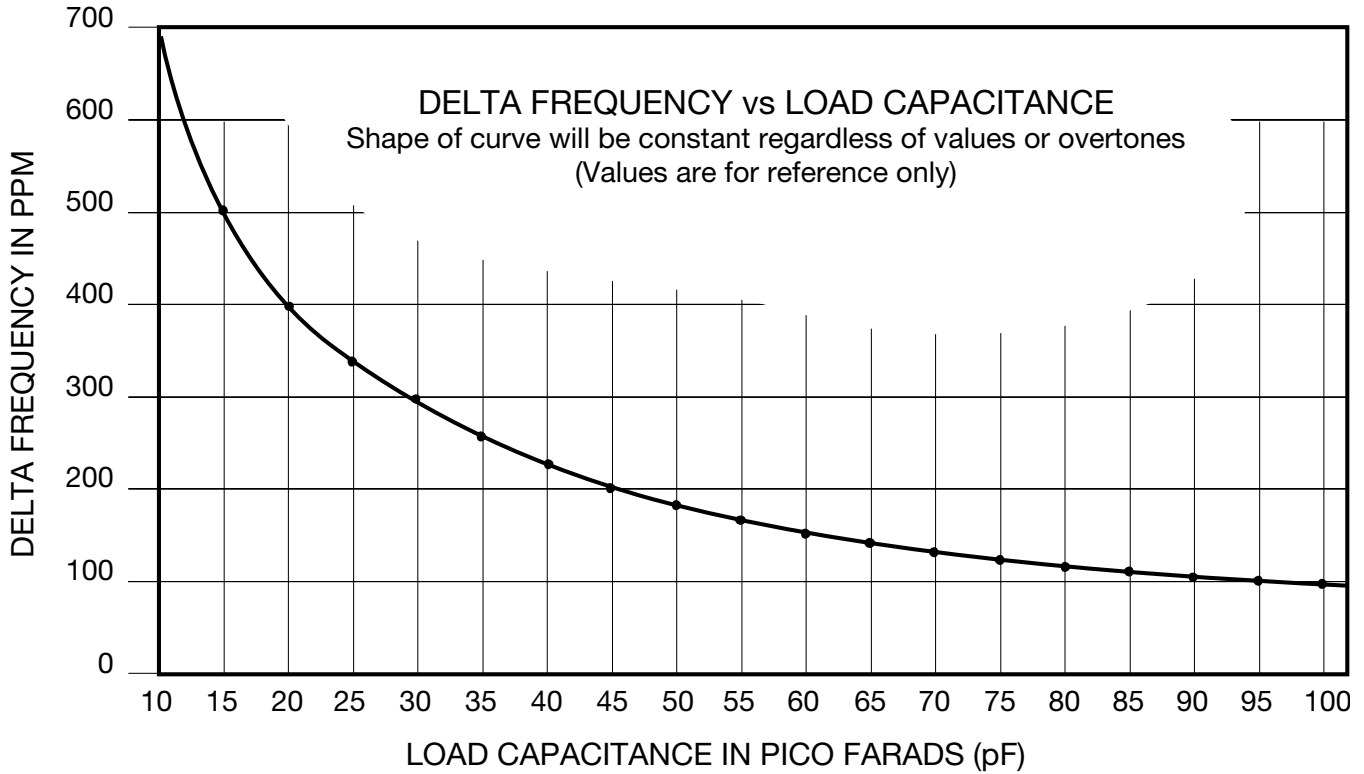

Figure C) Pullability Curve

Impedance/Reactance Curve: A crystal has two frequencies of zero phase, as illustrated in Figure D. The first, or lower of the two, is the Series Resonance Frequency, denoted as (f_s). At this point, the crystal appears resistive in the circuit, impedance is at a minimum and current flow is maximum. As the frequency is increased beyond the point of series resonance, the crystal appears inductive in the circuit. When the reactances of the motional inductance and shunt capacitance cancel, the crystal is at the Frequency of Anti-resonance, denoted as (f_a). At this point, impedance is maximized and current flow is minimized.

Shock Characteristics: Although crystals are designed to handle normal shock in handling, shock impulses (such as half sine, square, sawtooth and complex combinations) can occur in the field. Because crystals are relatively delicate, they should be isolated from equipment to minimize shock damage. But, avoid overspecification, since the elastic properties of the materials and the degree of isolation afforded by the equipment can decrease the destructive potential of a shock.

Quality Factor (Q): The "Q" value of a crystal unit is a measure of the units relative quality, or efficiency of oscillation. The maximum attainable stability of a crystal unit is dependent on the "Q" value. In Figure D the separation between the series and parallel frequencies is called the bandwidth. The smaller the bandwidth, the higher the "Q" value, and the

steeper the slope of the reactance. Changes in the reactance of external circuit components have less effect (less "pullability") on a high "Q" crystal, therefore such a part is more stable.

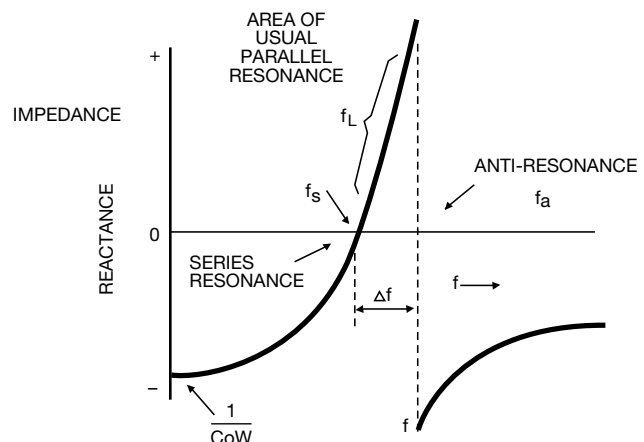

Figure D) Reactance vs. Frequency Curve

Calculation of Load Capacitance: If the circuit configuration is as shown in Figure A for the parallel version, the load capacitance may be calculated by means of the following equation:

$$CL = \frac{CL1 * CL2}{CL1 + CL2} + Cstray$$

Cstray includes the pin to pin input and output capacitance of the microprocessor chip at the *Crystal 1* and *Crystal 2* pins, plus any parasitic capacitances. As a rule of thumb, Cstray may be assumed to equal 5.0 pF. Therefore, if CL1 = CL2 = 5OpF, CL = 3OpF.

Trim Sensitivity: Trim sensitivity is a measure of the incremental fractional frequency change for an incremental change in the value of the load capacitance. Trim sensitivity (S) is expressed in terms of PPM/pF and is calculated by the following equation:

$$S = \frac{C1 * 1000000}{2 * Ct^2}$$

Where (Ct) is the sum of Co and CL.

Solder Reflow of Surface Mount Devices: Mounting of SMD units is typically accomplished by means of solder reflow, as indicated in Figure E either by infrared heat or by vapor phase. The following graphs depicts the recommended times and temperatures for each of the two methods:

Infrared - Reflow

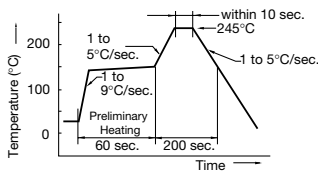

Vapor Phase - Reflow

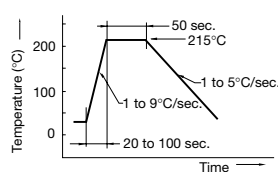

Figure E) Time Temperature Profiles

Soldering Characteristics: A variety of methods can be used to solder ECS products to P.C.B.s and substrates:

- Wave or Dual Wave
- Hot Air or Convection Flow
- Vapor Phase Reflow
- Infrared Reflow
- Bubble Solder Immersion
- Other (Laser, etc.)

PRODUCT	SOLDERING TEMP. T(C°)	SOLDERING TIME t(sec.)
HC-49, HC-49US, UM-1,5	240°~250°	20 sec. max.
ECS-1x5, 2x6, 2x8, 3x10, 31 all SMD Devices	230°	10 sec. max.
All Clock Oscillators	240°~250°	20 sec. max.

Due to the natural characteristics of material, some of our products cannot withstand heat shock. Extreme temperatures can cause tin (Sn) plating from the inside of the enclosure to reach its melting point, depositing solder on the quartz element. This can cause the component to oscillate at a lower frequency or fail completely. In other cases, solder contact can degrade, resulting in an open circuit. These problems can be

avoided by preheating the components and board, and following the recommended soldering process time/temperature profiles noted above.

Note: It is important to check with your ECS factory representative before subjecting any crystal components to extreme environmental conditions.

Useful Crystal Equations:

EQUATION	LEGEND
$f_s = \text{(Series) frequency} = \frac{1}{2\pi \sqrt{L_1 C_1}}$	f = Nominal freq. in Hz
$f_L - f_s = \Delta f = \frac{C_1}{2(C_0 + C_L)}$	f _s = Series resonant freq. in Hz
$L_1 = \text{Motional Inductance} = \frac{1}{4\pi^2 f_s^2 C_1}$	f _L = Anti-resonant freq. in Hz
$C_1 = \text{Motional capacitance} = 2(C_0 + C_L)\Delta f$	L = Inductance into Henrys
$Q = \text{Quality factor} = \frac{2\pi * f_s * L_1}{R_1}$	C ₁ = Motional capacit. in farads
$R_1 = \text{Series resistance} = \frac{2\pi * f_s * L_1}{Q}$	C ₀ = Static capacit. in farads
$C_0 = \text{Shunt capacitance} = \frac{C_1}{2 * \Delta f} - C_L$	C _L = Load capacit. in farads
$C_L = \text{Load capacitance} = \frac{C_1}{2 * \Delta f} - C_0$	R ₁ = Series resistance Ω
$P_L = \text{Pullability} = \frac{C_1 * 10^6}{2(C_0 + C_L)^2}$	Q = Quality factor
	P _L = Pullability (ppm/pF)

Field Vibration: There are two basic types of vibration, periodic and random. Typically, vibration in the field produces complex waves of motion which can affect the output of quartz crystals. Most failures due to vibration occur as a direct result of mechanically amplified resonances, as higher acceleration levels are reached by resonant areas, resulting in higher potential for damage. All factors influencing vibrations should be thoroughly evaluated by using a prototype. Structural system, component location, mounting and encapsulation should all be considered to maximize stability. Remember that crystals are designed to withstand normal handling vibration; added ruggedizing may adversely affect desirable qualities such as stability tolerance or aging.

The purpose of these application notes is to help customers in specifying Clock Oscillators. Background information about the type of Oscillators offered by ECS is included along with some common definitions and helpful formulas. The ECS Oscillator product line consists of Clock Oscillators, TCXOs, VCXOs, VCTCXOs and VCOs.

Clock Oscillator: The standard clock oscillator is the most common type of oscillator used and has applications in virtually every aspect of the electronics industry. The clock oscillator is used to establish a reference frequency used for timing purposes. A typical application is the sequencing of events in a computer.

A crystal controlled clock oscillator typically consist of an amplifier and a feedback network that selects a part of the amplifier output and returns it to the amplifier input. A simplified block diagram of such a circuit is shown below in (Fig. 1).

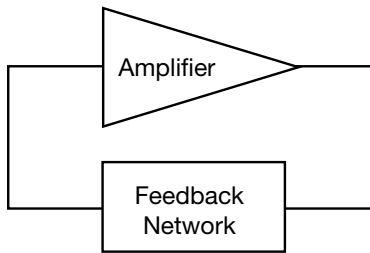

Figure 1) Simplified Block Diagram of a Crystal Controlled Clock Oscillator

The basic criteria for oscillation in an oscillator are: 1. The open loop gain must be greater than the losses around the oscillator loop and 2. The phase shift around the oscillator loop must be either 0 or 360 degrees.

An oscillator can be used to generate different types of waveforms. The most common types of waveforms produced by an oscillators are sinusoidal and square.

The main parameters used in specifying a clock oscillator are listed below.

Logic TTL, HCMOS: In general, an HCMOS oscillator will drive TTL circuitry (not vice versa). The industry is moving away from the TTL logic as IC manufacturers are discontinuing the supply of many common TTL IC's. Most ECS clock oscillators are HCMOS/TTL compatible.

Frequency Stability: The most common stabilities are 25, 50 and 100 PPM. Overall stability usually includes accuracy at 25°C, effects due to changes in operating temperature, input voltage, aging, shock and vibration. The ± 100 PPM stability has been the most popular as it is sufficient to run microprocessors. The telecommunications industry has been moving toward tighter and tighter stabilities. Stabilities beyond ± 100 PPM are no longer offered in commercial (0-70°C) applications, since standard process controls achieve this stability as a minimum. Requesting 50 PPM is usually a little more expensive. Clock Oscillators requiring 25 PPM can significantly affect the price. For tighter than 25 PPM stability applications, please consult the factory or consider a TCXO.

TCXOs (Temperature Compensated Crystal Oscillators)

typically consists of tight tolerance quartz crystal, a temperature compensation network, an oscillator circuit and a variety of buffer and/or output stages determined by the output requirement. The crystal has a characteristic of changing frequency when a capacitor is inserted in series with the crystal unit as shown in (Fig. 2).

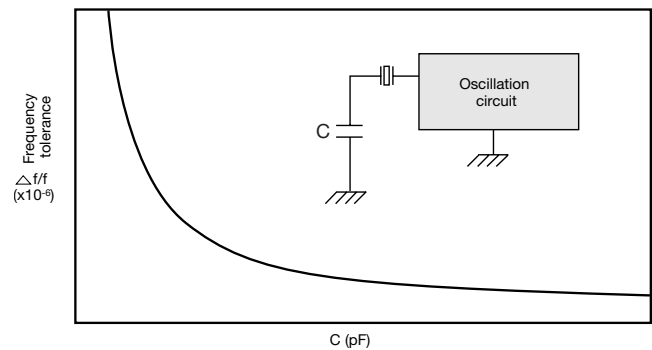

Figure 2) Load Capacitance Characteristics of Crystal Unit

Utilizing the above characteristics, frequency can be stabilized by inserting a temperature compensation circuit consisting of thermistors, resistors and capacitors in the oscillation loop as shown in (Fig. 3). The temperature compensation network is used to sense the ambient temperature and "pull" the crystal frequency in a manner which reduces frequency vs. temperature effect of the quartz crystal.

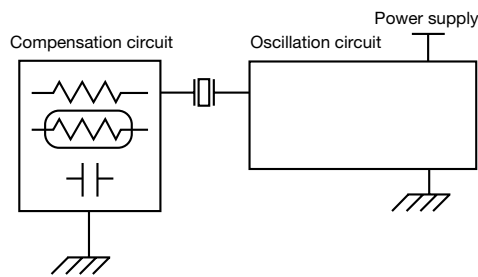

Figure 3) Temperature Compensation Circuit

A TCXO is generally required when overall stability needs are greater than those of a clock oscillator. Also, the long term aging effects of a TCXO are better than those of most clock oscillators.

Input Voltage: Most TCXOs are designed to operate at 5VDC, 3.3 VDC or a combination of both.

RF Output: A TCXO can be manufactured with various types of outputs: sine wave, clipped sine wave, TTL, HCMOS and ECL. Be sure to specify the desired output type, signal requirements and the load that the oscillator will be driving.

TCXOs also have a frequency adjustment feature which allow for re-adjustment of the oscillator to its center frequency to compensate for aging. This adjustment can be provided in the following ways.

- 1) A mechanical adjustment (internal trimmer) within the oscillator accessible via hole in the enclosure.
- 2) An electrical adjustment via a lead in the enclosure for either a remotely located potentiometer or a voltage. An oscillator using this technique is called a Temperature Compensated Voltage Controlled Crystal Oscillator or TCVCXO.
- 3) A combination of both mechanical and electrical adjustment.

VCXOs (Voltage Controlled Crystal Oscillator) are crystal controlled oscillators in which the output frequency can be adjusted by varying the external control voltage across a variable capacitor (varactor diode) within the oscillator circuit. The associated change in frequency due to the change in control voltage is known as pullability. VCXOs are used widely in telecommunications, instrumentation and other electronic equipment where a stable but electrically tunable oscillator is required.

The varactor diode is a semiconductor device that is designed to act as a variable capacitor when a voltage is applied to it. When used in series with a crystal, as shown in (Fig. 4), changing the control voltage causes diode capacitance to change. This change in capacitance causes the total crystal load capacitance to change and subsequently causes a change in crystal frequency.

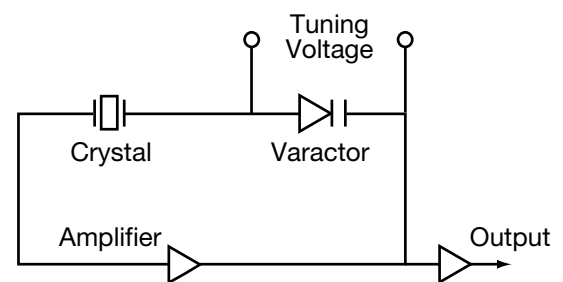

Figure 4) Typical VCXO circuit

Due to the growing applications of VCXOs in digital data transmissions phase jitter (short-term stability) has become an important consideration. Phase jitter provides a precise way to establish when a phase transition occurs.

Definitions: The following definitions will aid you in understanding oscillator performance and terminology.

Nominal Frequency: The center or nominal output of a crystal oscillator.

Frequency Tolerance: The deviation from the nominal frequency in terms of parts per millions (PPM) at room temperature. ($25^{\circ}\text{C} \pm 5^{\circ}\text{C}$)

Frequency Range: The frequency band that the oscillator type or model can be offered.

Frequency Stability: The maximum allowable frequency deviation compared to the measured frequency at 25°C over the temperature window, i.e. 0°C to $+70^{\circ}\text{C}$. The typical stability for clock oscillators is $\pm 0.01\%$ (± 100 PPM).

Operating Temperature: Temperature range within which output frequency and other electrical, environmental characteristics meet the specifications.

Aging: The relative frequency change over a certain period of time. Typically, aging for clock oscillators is ± 5 PPM over 1 year maximum.

Storage Temperature: The temperature range within which the unit is safely stored without damaging or changing the performance of the unit.

Supply Voltage: The maximum voltage which can safely be applied to the VCC terminal with respect to ground.

Input Voltage (VIN): The maximum voltage which can be safely applied to any input terminal of the oscillator.

Output HIGH Voltage (VOH): The minimum voltage at an output of the oscillator under proper loading.

Output LOW Voltage (VOL): The maximum voltage at an output of the oscillator under proper loading.

Input HIGH Voltage (VIH): The minimum voltage to guarantee threshold trigger at the input of the oscillator.

Input LOW Voltage (VIL): The maximum voltage to guarantee threshold trigger at the input of the oscillator.

Supply Current: The current flowing into Vcc terminal with respect to ground. Typically supply current is measured without load.

Symmetry or Duty Cycle: The symmetry of the output waveform at the specified level (at 1.4 V for TTL, at $1/2 V_{cc}$ for HCMOS, or $1/2$ waveform peak level for ECL).

Rise Time (TR): Waveform rise time from Low to High transition measured at the specified level (20% to 80% for HCMOS, ECL and 0.4 V to 2.4 V for TTL).

Fall Time (TF): The waveform fall time from High to Low transition, measured at the specified level (80% to 20% for the HCMOS, ECL and 2.4 V to 0.4V for TTL).

Load/Fan Out: The maximum load that the different families of oscillators can drive is defined as the output load driving capability. The load driving capability (fan-out) of each family of oscillators is specified in terms of the number of gates an oscillator can drive.

Jitter (short-term stability): The modulation in phase or frequency of the oscillator output.

HCMOS/TTL Compatible: The oscillator is designed with CMOS logic with driving capability of TTL and HCMOS loads while maintaining minimum logic High of HCMOS.

Tri-State Enable: When the input is left OPEN or tied to logic "1" the normal oscillation occurs. When the input is grounded (tied to logic "0", the output is in HIGH IMPEDANCE state. The input has an internal pull-up resistor thus allowing the input to be left open.

Output Logic: The output of an oscillator is designed to meet various specified logic's, such as TTL, HCMOS, ECL, Sine, Clipped-Sine (DC cut).

Harmonic Distortion: The non-linear distortion due to unwanted harmonic spectrum component related with target signal frequency. Each harmonic component is the ratio of electric power against desired signal output electric power and is expressed in terms of dbc, i.e. -20 dbc. Harmonic distortion specification is important especially in sine output when a clean and less distorted signal is required.

Dual and Multiple Outputs: More than one signal is capable of being generated from a single oscillator. The signals may be related (usually a multiple or divisor of the signal produced by a single crystal).

Start-Up Time: The start up time of an oscillator is defined as the time an oscillator takes to reach its specified RF output amplitude.

Crystal controlled oscillators may be considered as consisting of an amplifier and a feedback network that selects a part of the amplifier output and returns it to the amplifier input. A generalized depiction of such a circuit is shown below.

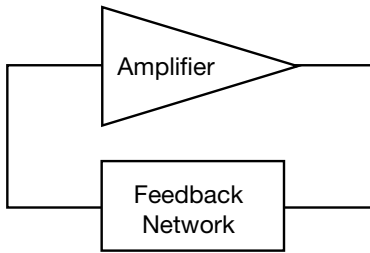

Figure A) Amplifier Feedback Network

In order for an oscillator circuit to operate, two (2) conditions must be met:

- (A) The loop power gain must be equal to unity.
- (B) The loop phase shift must be equal to $0, 2\pi, 4\pi$, etc. radians

The power fed back to the input of the amplifier must be adequate to supply the oscillator output, the amplifier input and to overcome circuit losses.

The exact frequency at which an oscillator will operate is dependent on the loop phase angle shifts within the oscillator circuit. Any net change in phase angle will result in a change in the output frequency. As the usual goal of an oscillator is to provide a frequency that is essentially independent of variables, some means of minimizing the net phase shift must be employed. Perhaps the best, and certainly the most common means of minimizing the net phase shift is to use a quartz crystal unit in the feedback loop.

The impedance of a quartz crystal changes so dramatically with changes in the applied frequency that all other circuit components can be considered as being of essentially constant reactance. Therefore, when a crystal unit is used in the feedback loop of an oscillator, the frequency of the crystal unit will adjust itself so that the crystal unit presents a reactance which satisfies the loop phase requirements. A depiction of the reactance vs. frequency of a quartz crystal unit is shown below.

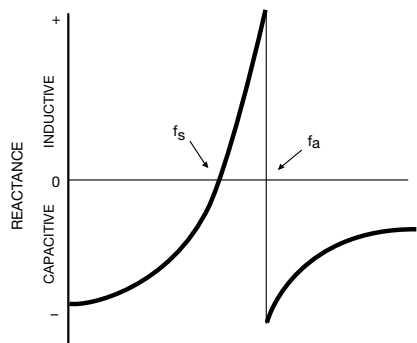

Figure B) Reactance vs. Frequency Curve

As is apparent from Figure B, quartz crystal unit has two frequencies of zero phase. The first, or lower of the two, is the series resonant frequency, usually abbreviated as F_s . The second, or higher of the two frequencies of zero phase is the parallel, or anti-resonant frequency, usually abbreviated as F_a . Both the series and parallel resonant frequencies appear resistive in an oscillator circuit. At the series resonant point, the resistance is minimal and the current flow is maximal.

At the parallel point, the resistance is maximal and the current flow is minimal. Therefore, the parallel resonant frequency, F_a , should never be used as the controlling frequency of an oscillator circuit.

A quartz crystal unit can be made to oscillate at any point along the line between the series and parallel resonant points by the inclusion of reactive components (usually capacitors) in the feedback loop of the oscillator circuit. In such a case, the frequency of oscillation will be higher than the series resonant frequency but lower than the parallel resonant frequency. Because of the fact that the frequency resulting from the addition of capacitance is higher than the series resonant frequency, it is usually called the parallel frequency, though it is lower than the true parallel frequency.

Just as there are two frequencies of zero phase associated with a quartz crystal unit, there are two primary oscillator circuits. These circuits are generally described by the type of crystal unit to be used, namely "series" or "parallel."

SERIES CIRCUIT: A series resonant oscillator circuit uses a crystal which is designed to operate at its natural series resonant frequency. In such a circuit, there will be no capacitors in the feedback loop. Series resonant oscillator circuits are used primarily because of their minimal component count. These circuits may, however, provide feedback paths other than through the crystal unit. Therefore, in the event of crystal failure, such a circuit may continue to oscillate at some arbitrary frequency. A depiction of a basic series resonant oscillator circuit is given below.

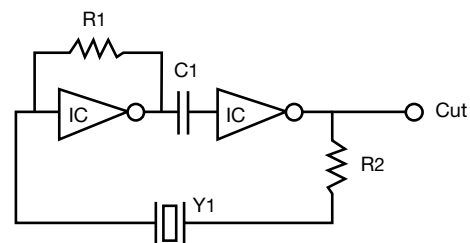

Figure C) Series Resonant Oscillator Circuit

As is apparent from Figure C, a series resonant oscillator circuit provides no means of adjusting the output frequency, should adjustment be required. In the above circuit, resistor R_1 is used to bias the inverter and to cause it to operate in its linear region. This resistor also provides negative feedback to the inverter. Capacitor C_1 is a coupling capacitor, used to block DC voltage. Resistor R_2 is used to bias the crystal unit. This resistor strongly influences the drive current seen by the crystal unit, therefore care must be taken that too small a value is not chosen. Crystal unit Y_1 is a series resonant crystal unit, specified to operate at the desired frequency and with the desired frequency tolerance and stability.

PARALLEL CIRCUIT: A parallel resonant oscillator circuit uses a crystal unit which is designed to operate with a specified value of load capacitance. This will result in a crystal frequency which is higher than the series resonant frequency but lower than the true parallel resonant frequency. These circuits do not provide paths other than through the crystal unit to complete the feedback loop. In the event of crystal unit failure, the circuit will not continue to oscillate. A basic depiction of a parallel resonant circuit is given below.

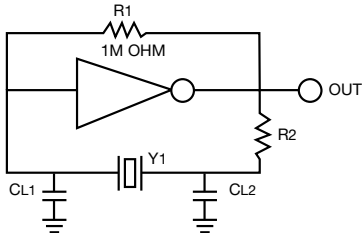

Figure A) Parallel Resonant Circuit

FREQUENCY (MHz)	CL1, CL2, (pF)	R2 (Ω)	CL (pF)
3 ~ 4	27	5.6k	16
4 ~ 5	27	3.9k	16
5 ~ 6	27	2.7k	16
6 ~ 8	18	2.7k	12
8 ~ 12	18	1.8k	12
12 ~ 15	18	1.0k	12
15 ~ 20	15	560	10
20 ~ 25	12	560	10

Figure A1) Typical Values for a Parallel Circuit

This circuit uses a single inverter, with two capacitors in the feedback loop. These capacitors comprise the “load capacitance” and together with the crystal unit, establish the frequency at which the oscillator will operate. As the value of the load capacitance is changed, so is the output frequency of the oscillator. Therefore, this circuit does provide a convenient means of adjusting the output frequency, should adjustment be required.

The resistors R1 and R2 serve the same functions as detailed for the series resonant circuit shown in Figure C. The two load capacitors, CL1 and CL2, serve to establish the frequency at which the crystal unit and therefore the oscillator will operate. Crystal unit Y1 is a parallel resonant crystal unit, specified to operate with a specified value of load capacitance, at the desired frequency and with the desired frequency tolerance and stability.

LOAD CAPACITANCE: Reference has been made to a “specified load capacitance.” Load capacitance may be defined as “that value of capacitance, either measured or calculated, present in the oscillator circuit, across the connection points of the crystal.” In the case of a series resonant circuit, there is no capacitance present between the connecting points of the crystal unit and therefore, load capacitance need not be specified for a series resonant crystal unit. In the case of a parallel resonant oscillator circuit, capacitance is present. As a direct measurement of this capacitance is impractical, it is usually necessary to calculate the value.

The calculation of the value of the load capacitance is done with the following equation:

$$CL = \frac{CL1 * CL2}{CL1 + CL2} + Cs \quad (1)$$

Where CL 1 and CL2 are the load capacitors and Cs is the circuit stray capacitance, usually 3.0 to 5.0 pF.

It must be noted that changes in the value of the load capacitance will result in changes in the output frequency of the oscillator. Therefore, if precise frequency control is required, then a precise specification of load capacitance is required. To illustrate, assume that a crystal unit is specified to operate at a frequency of 20.000 MHz with a load capacitance of 20.0 pF. Assume that the crystal unit is then placed in a circuit which presents a value of 30.0 pF. The frequency of the crystal unit will then be lower than the specified value. Conversely, should the circuit in question present a value of 10.0 pF, the frequency will be higher than the specified value. The relationship between frequency and load capacitance is shown below.

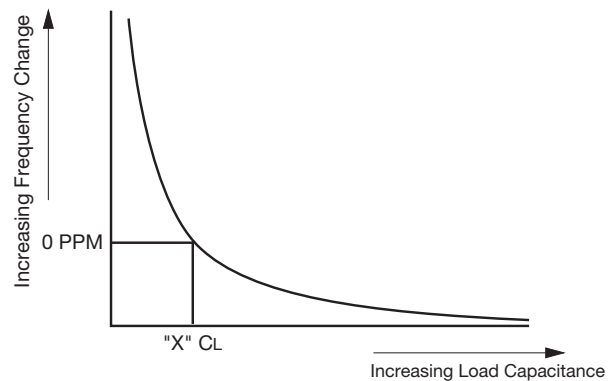

Figure E) Frequency vs Load Capacitance

DRIVE LEVEL: The “drive level” is the power dissipated by the crystal unit while operating. The power is a function of the applied current and is usually expressed in terms of Milliwatts or Microwatts. Crystal units are specified as having certain **maximum** values of drive level, which change as functions of the frequency and mode of operation. It is well to consult with the crystal unit vendor as to the maximum value of drive level allowed for a particular crystal unit. Exceeding the maximum drive level for a given crystal unit may result in unstable operation increased aging rates, and in some cases, catastrophic damage. The drive level may be calculated by the following equation

$$POWER = (I_{rms}^2 * R) \quad (2)$$

Where I is the rms current through the crystal unit and R is the maximum resistance value of the specific crystal unit in question. Equation (2) is simply “Ohms law” for power.

Measurement of the actual drive level in an operating oscillator circuit may be accomplished by temporarily inserting a resistor in series with the crystal unit. The resistor must be of the same ohmic value as the crystal unit. The voltage drop across the resistor may then be read and the current and power dissipation calculated. The resistor must then be removed. As an alternative means of measuring the drive level, a current probe may be used at the output lead of the crystal unit, space permits. The method is described below in Figure 1.

$$R_L = R_1 \left(1 + \frac{C_0}{C_L} \right)^2$$

where R_L = loaded resonance resistance
 R_1 = resonance resistance of crystal unit
 I_q = current flowing to crystal unit
 C_0 = shunt capacitance
 C_L = load capacitance

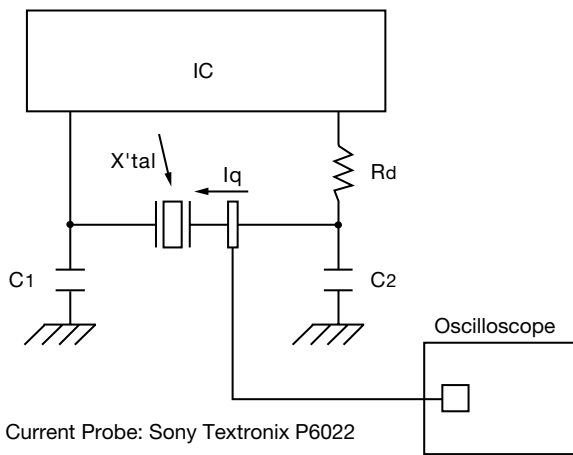

Figure 1) Drive Level Measurement

FREQUENCY vs MODE: The frequency of a quartz crystal unit is limited by the physical dimensions of the vibrating quartz element. In some cases, the limiting dimension (s) are the length and width. In the case of the most popular crystal unit, the "AT" cut crystal unit, the limiting dimension is the thickness of the vibrating quartz element. As the thickness is diminished, the frequency is increased. At some point, usually around 30,000 MHz, the thickness of the quartz plate becomes too thin for processing.

Should it be desired to develop an oscillator at a frequency higher than the limiting frequency, advantage must be taken of the fact that quartz crystal units will oscillate at odd integer multiples of their "fundamental" frequency. We may define the "fundamental" frequency as "that frequency which naturally occurs at a given set of mechanical dimensions." Therefore, if a crystal unit has a fundamental frequency of 10.0 MHz, it can also be made to oscillate at 3, 5, 7, etc. times the fundamental. That is, the unit will oscillate at 30.0, 50.0, 70.0, etc. MHz.

These multiples of the fundamental frequency are called "overtones" and are identified by the integer of multiplication, as in the "third overtone", the "fifth overtone", etc. When use at an overtone frequency is required, The crystal unit must be specified to operate at the desired frequency and on the desired overtone. One should never attempt to order a fundamental mode crystal unit and then operate it at an overtone frequency. This is due to the fact that the crystal manufacturing processes differ for fundamental and overtone crystal units.

In many cases, the characteristics of the integrated circuit used in a particular oscillator design dictate that the fundamental frequency of the crystal unit be suppressed in order to ensure operation at the desired frequency and on the desired overtone. In such cases, it is usually necessary to modify the oscillator circuit. One method of modification is to add a "tank" circuit, consisting of an inductor and a capacitor. These modifications are shown in Figure F and G.

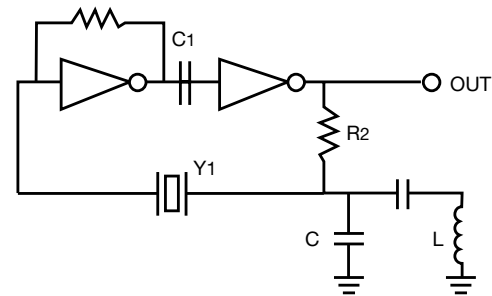

Figure F) Modifications of a Series Resonant Circuit

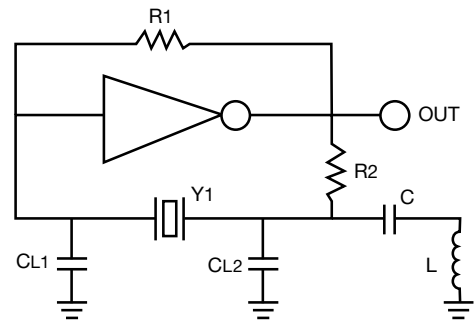

Figure G) Modifications of a Parallel Resonant Circuit

In both cases, the tank circuit is tuned to resonate at some frequency between the fundamental and the desired frequency. This results in the unwanted frequency being shunted to ground, leaving only the desired frequency being present at the output of the oscillator.

DESIGN CONSIDERATIONS: For good operation of an oscillator circuit, certain design considerations should be followed. In all cases, it is recommended that parallel traces be avoided in order to reduce circuit stray capacitance. All traces should be kept as short as possible and components should be isolated in order to prevent coupling. Ground planes should be used to isolate signals.

NEGATIVE RESISTANCE: For optimum performance, an oscillator circuit must be designed in such a way as to enhance “negative resistance,” which is sometimes called the “oscillation allowance.” Evaluation of the amount of negative resistance in a given circuit is accomplished by temporarily installing a variable resistor in series with the crystal unit. The resistor should be set initially at its lowest setting, preferably close to zero ohms. The oscillator is then started and the output monitored on an oscilloscope. The variable resistor is then adjusted so that resistance is increased while the output is continuously monitored. At some value of resistance, oscillation will be stopped. At this point, the variable resistor is measured to determine the ohmic value at which oscillation ceased. To this value, the maximum resistance of the crystal unit, as specified by the vendor, must be added. The total ohmic resistance is deemed to be the “negative resistance” or the “oscillation allowance.” For good, reliable circuit operation, it is recommended that the negative resistance be a minimum of five times the specified maximum resistance value of the crystal unit.

Values of negative resistance exceeding five times the maximum resistance of the crystal unit are better yet. As negative resistance tends to decrease at elevated temperatures, it is recommended that the test be performed at the highest temperature of the operating range. See the special procedure illustrated below.

Procedures For Negative Resistance Measurement

- 1) Open either end of the crystal unit in the main circuit used, and insert a variable resistor in series with the crystal unit, as shown. Change the resistance value to examine the limits of oscillation and resistance in ohms observed at that time. In this case power must be turned on and off, without fail.
 - 2) Negative resistance (-R) in the circuit is the sum of the value obtained by Step 1) above and the resonant resistance R1 of the crystal.
- Note: This measurement should be carried out at both the upper and lower limits of the operating temperature range.*
- 3) C1 and C2 should be used within the range of 10 ~ 30 pF. If C1 and C2 are used below 10 pF or above 30 pF, oscillation performance may be easily affected. Drive Level may increase, or negative resistance may decrease, thus failure to maintain oscillation.

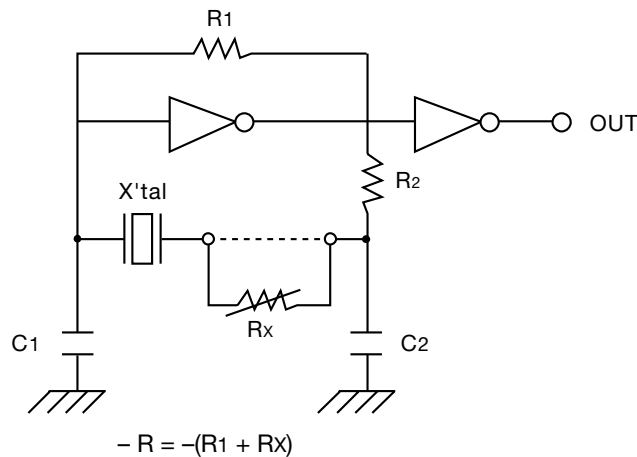

Figure H) Negative Resistance Measurement Procedure

Principles of Operation for Ceramic Resonators

Equivalent Circuit Constants: Fig.1.2 shows the symbol for a ceramic resonator. The impedance and phase characteristics measured between the terminals are shown in Fig.1.5. This figure illustrates that the resonator becomes inductive in the frequency range between the frequency f_r (resonant frequency), which provides the minimum impedance, and the frequency f_a (anti-resonant frequency), which provides the maximum impedance. It becomes capacitive in other frequency ranges. This means that the mechanical oscillation of a two-terminal resonator can be replaced with an equivalent circuit consisting of a combination of series and parallel resonant circuits with an inductor L , a capacitor C , and a resistor R . In the vicinity of the resonant frequency, the equivalent circuit can be expressed as shown in Fig.1.4.

The f_r and f_a frequencies are determined by the piezoelectric ceramic material and its physical parameters. The equivalent circuit constants can be determined from the following formulas:

$$f_r = \frac{1}{2\pi} \sqrt{\frac{1}{L_1 C_1}}$$

$$f_a = \frac{1}{2\pi} \sqrt{\frac{1}{L_1 C_1 C_0 / (C_1 + C_0)}} = f_r \sqrt{1 + C_1 / C_0}$$

$$Q_m = \frac{1}{2\pi} \frac{f_r}{R_1} \quad (Q_m = \text{Mechanical } Q)$$

Considering the limited frequency range of $f_r \leq f \leq f_a$, the impedance is given as $Z = R_e + j\omega L_e$ ($L_e \leq 0$) as shown in Fig.1.5. The ceramic resonator should operate as an inductor L_e (H) having the loss R_e (Ω).

Fig.1.1 shows comparisons for equivalent circuit constants between a ceramic resonator and a quartz crystal resonator. Note there is a large difference in capacitance and Q_m which results in the difference of oscillating conditions when actually operated. The table in the appendix shows the standard values of equivalent circuit constants for each type of ceramic resonator.

Higher harmonics for other modes of oscillation exist other than the desired oscillation mode. These other oscillation modes exist because the ceramic resonator uses mechanical resonance. Fig.1.6 shows these characteristics.

FREQUENCY	CERAMIC RESONATOR				CRYSTAL			
	455KHz	2.50MHz	4.00MHz	8.00MHz	453.5KHz	2.457MHz	4.00MHz	8.00MHz
L_1 (μ H)	8.8×10^3	1.0×10^3	385	72	8.6×10^3	7.2×10^3	2.1×10^3	1.4×10^4
C_1 (pF)	14.5	4.2	4.4	5.9	0.015	0.005	0.007	0.027
C_0 (pF)	256.3	33.3	36.3	39.8	5.15	2.39	2.39	5.57
R_1 (Ω)	9.0	17.6	8.7	4.8	1060	37.0	22.1	8.0
Q_m	2734	912	1134	731	23000	298869	240986	88677
ΔF (KHz)	12	147	228	555	0.6	3	6	19

Figure 1.1 Comparisons of equivalent Circuit Constants for Ceramic and Crystal Resonators

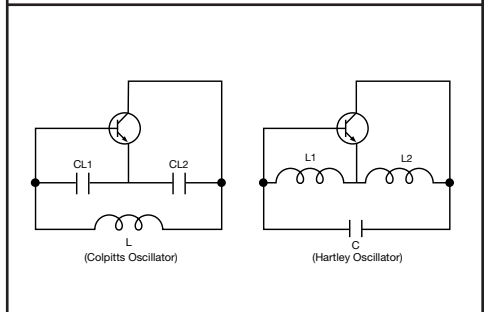
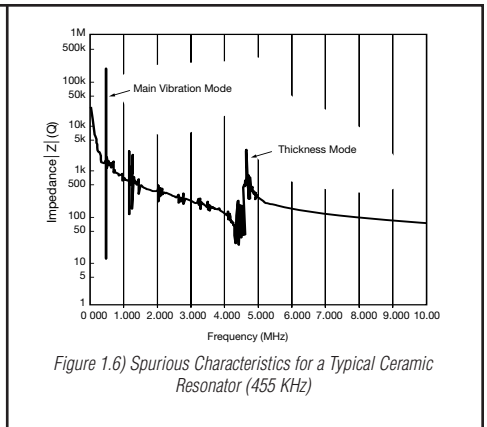
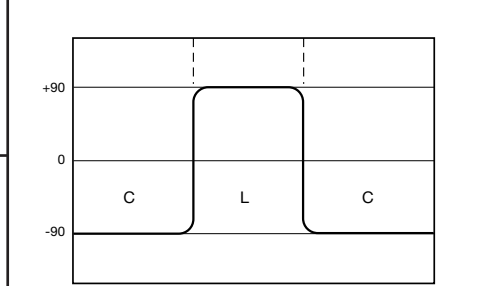
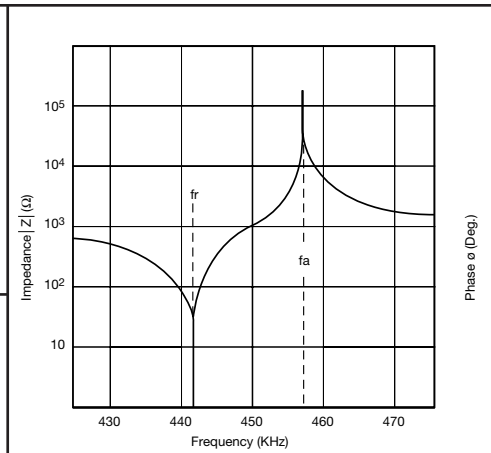
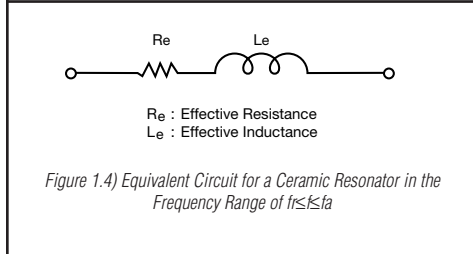
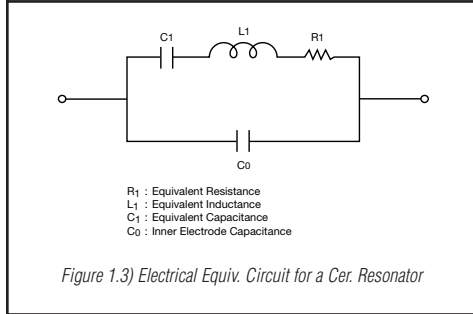
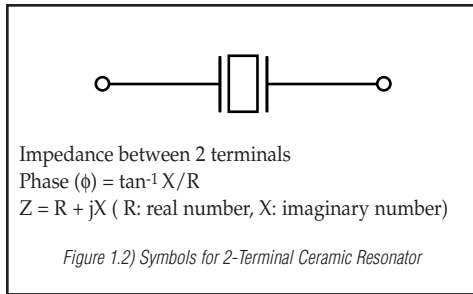

Basic Oscillating Circuits

Generally, the oscillating circuits can be grouped into the following three types:

1. Positive feedback
2. Negative resistance element
3. Delay of transfer time or phase in the case of ceramic resonators, quartz crystal resonators, and LC oscillators, positive feedback is the circuit of choice.

Among the positive feedback oscillation circuits using LC, the tuning type anti-coupling oscillation circuit, by Colpitts and Hartley, are typically used. See Fig. 1.7.

In Fig.1. 7, a transistor, which is the most basic amplifier, is used.

The oscillation frequencies are approximately the same as the resonance frequency of the circuit consisting of L, C_{L1}, and C_{L2} in the Colpitts circuit or consisting of L₁, L₂, and C in the Hartley circuit. These frequencies can be represented by the following formulas.

Colpitts Circuit

$$f_{osc} = \frac{1}{2\pi} \sqrt{L_1 * [(C_{L1} * C_{L2}) / (C_{L1} + C_{L2})]}$$

Hartley Circuit

$$f_{osc} = \frac{1}{2\pi} \sqrt{C (L_1 + L_2)}$$

In a ceramic resonator oscillator, the inductor is replaced by a ceramic resonator, taking advantage of the fact that the resonator becomes inductive between resonant and anti-resonant frequencies. The most commonly used circuit is the Colpitts circuit.

The operating principle of these oscillation circuits can be seen in Fig.2.1. Oscillation occurs when the following conditions are satisfied.

Loop gain: $G = \alpha \cdot \beta \geq 1$

Phase amount: $\phi_T = \phi_1 + \phi_2 = 360^\circ \cdot n$ (n = 1,2,...)

In a Colpitts circuit, an inversion of $\phi_1 = 180^\circ$ is used, and it is inverted more than $\phi_2 = 180^\circ$ with L and C in the feedback circuit. The operation with a ceramic resonator can be considered as the same.

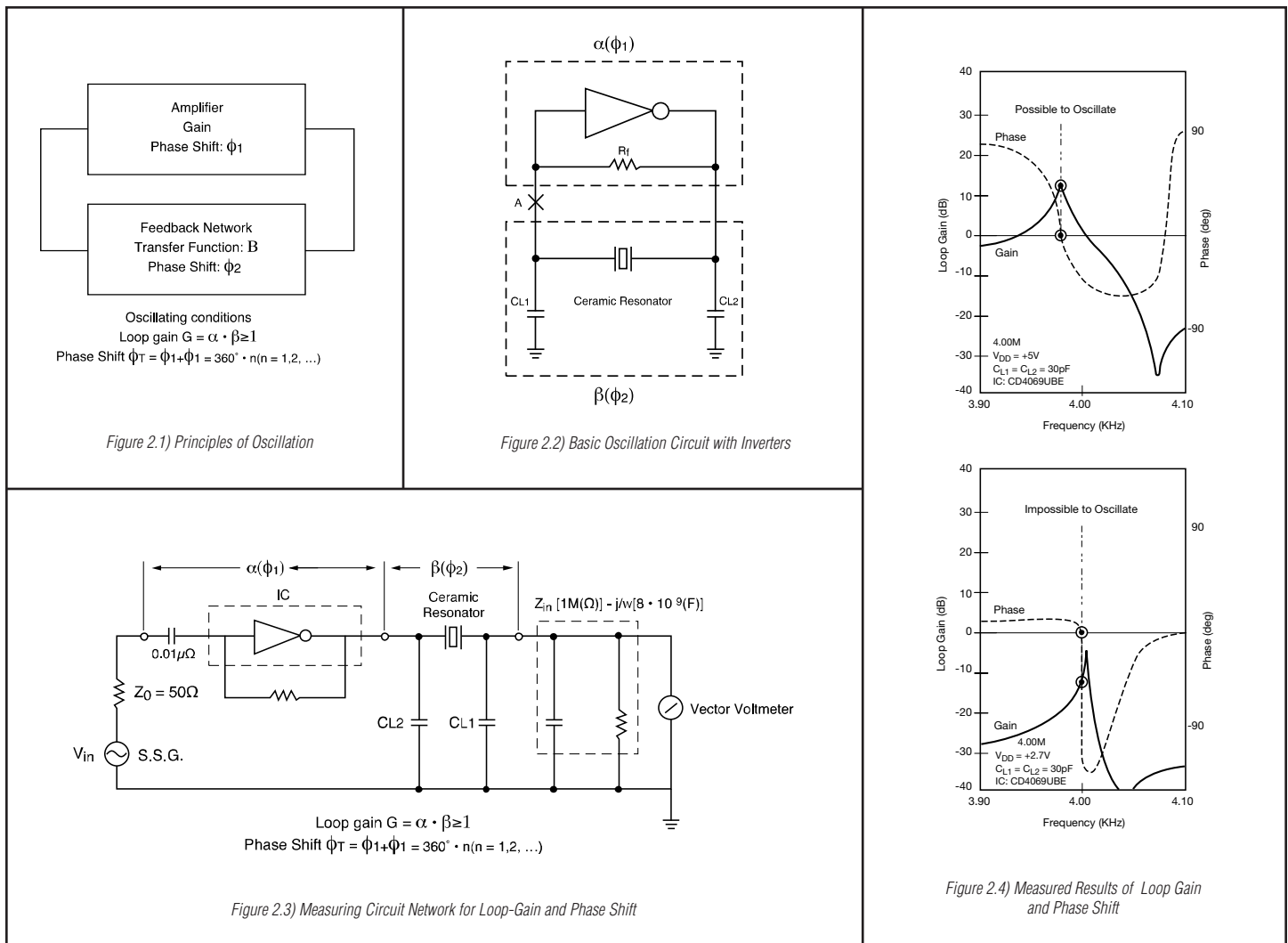

APPLICATIONS

Typical Oscillation Circuit: The most common oscillator circuit for a ceramic resonator is a Colpitts circuit. The design of the circuit varies with the application and the IC to be used, etc. Although the basic configuration of the circuit is the same as that of a crystal controlled oscillator, the difference in mechanical Q results from a difference in circuit constants. Some typical examples follow.

Design Considerations: It is becoming more common to configure the oscillation circuit with a digital IC, using an inverter gate. Fig.3.1 on the following page shows the configuration of a basic oscillation circuit with a CMOS inverter.

INV.1 operates as an inverting amplifier for the oscillating circuit. INV.2 is used as a waveform shaper and also acts as a buffer for the output.

The feedback resistance R_f provides negative feedback around the inverter so that oscillation will start when power is applied.

If the value of R_f is too large and the insulation resistance of the input inverter is low, then oscillation will stop due to the loss of loop gain. Also, if R_f is too great, noise from other circuits can be introduced into the oscillation circuit. Obviously, if R_f is too small, loop gain will be decreased. An R_f of $1M\Omega$ is generally used with a ceramic resonator.

Damping resistor R_d has the following function although it is sometimes omitted. It makes the coupling between the inverter and the feedback circuit loose; thereby, decreasing the load on the output side of the inverter. In addition, the phase of the feedback circuit is stabilized. It also provides a means of reducing the gain at higher frequencies, thus preventing the possibility of spurious oscillation.

Loading Capacitance: Load capacitance C_{L1} and C_{L2} provide a phase lag of 180° . These values should be properly selected depending on the application, the IC used, and the frequency. If C_{L1} and C_{L2} are lower values than necessary, the loop gain at high frequencies is increased, which in turn increases the probability of spurious oscillation. This is particularly likely around 4-5MHz where the thickness vibration mode lies.

Oscillation frequency (f_{osc}) in this circuit is expressed approximately by the following equation.

$$f_{osc} = f_r \sqrt{1 + (C_1 / C_0 + C_L)}$$

Where, f_r : Resonance frequency of the ceramic resonator.

C_1 : Equivalent series capacitance of the ceramic resonator.

C_0 : Equivalent parallel capacitance of the ceramic resonator.

$$C_L = C_{L1} + C_{L2} / C_{L1} + C_{L2}$$

This clearly shows that the oscillation frequency is influenced by the loading capacitance. Caution should be taken in defining its value when a tight tolerance for oscillation frequency is required.

CMOS Inverter: A CMOS inverter can be used as the inverting amplifier; the one-stage type of the 4069 CMOS group is most useful. Because of excessive gain, ring oscillation or CR oscillation is a typical problem when using the three-stage buffer type inverter, such as the 4049 group. ECS employs the RCA CD4069UBE as a CMOS standard circuit, as shown in Fig. 3.2.

HCMOS Inverter Circuit: Recently, the high speed CMOS (HCMOS) is increasingly being used for circuits allowing high speed and low power consumption for microprocessors.

There are two types HCMOS inverters: the un-buffered 74HCU series and the 74HC series with buffers. The 74HCU system is optimum for ceramic resonators. See Fig.3.3

TTL Inverter Circuit: The value of load capacitance C_{L1} and C_{L2} should be greater than those of CMOS due to impedance matching. In addition, the feedback resistance R_f should be as small as several $K\Omega$. Note that the bias resistance R_d is required to properly determine the DC operating point.

Frequency Correlation: The oscillator circuits shown on the following page are ECS standard test circuits. The inverters used in these circuits are widely accepted as industry standard because their characteristics are representative of those found in microprocessors within the same family (CMOS/HCMOS/TTL). Naturally, applications will differ in what IC is used, and as can be expected, oscillator circuit characteristics will vary from IC to IC.

Usually, this variation is negligible and a ceramic resonator part number can be selected simply by classifying the processor as CMOS, HCMOS or TTL.

Given that the standard ECS ceramic resonators are 100% frequency sorted to the test circuits on the following page, it is relatively easy to correlate the frequency of oscillation of our standard circuit to that of a customer specified circuit.

For example, if the microprocessor being used is a Motorola 6805at a frequency of 4MHz, then the correct ECS part number would be ZTA4.OMG (frequency sorted to the CD4069UBE CMOS test circuit). Circuit parameters should be selected as below:

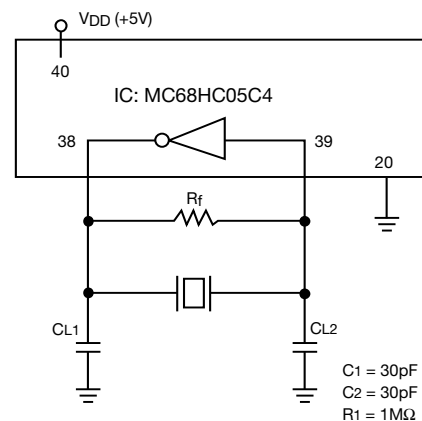

By actually setting up this circuit as well as the standard test circuit shown in Fig.3.1 below, it is possible to establish the average shift that can be expected when using the ZTA4.OMG with a 6805 processor. The actual data is shown below:

RESONATOR SAMPLE #	IC: MC6805C4	IC: CD4069UBE
1	3994.21	3991.80
2	3997.49	3995.46
3	4000.87	3997.96
4	3998.18	3995.96
5	4001.09	3998.87
X	3998.37	3996.01

From this data, it is possible to predict that the standard ZTA4.00MG resonator will have an approximate +0.06% frequency shift from the original 4.00MHz $\pm 0.5\%$ initial tolerance. This is of course a negligible shift and will not affect circuit performance in any way.

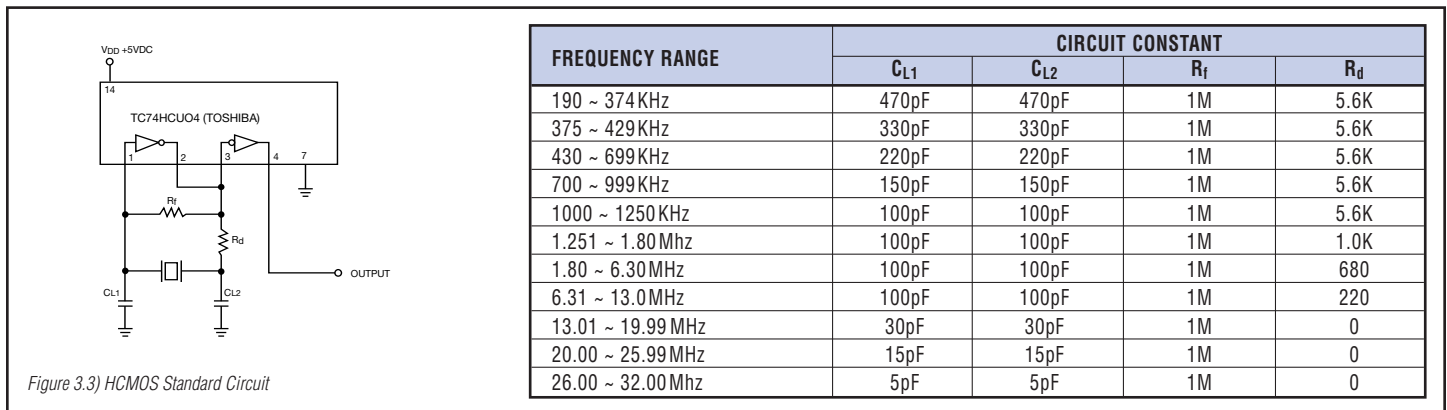
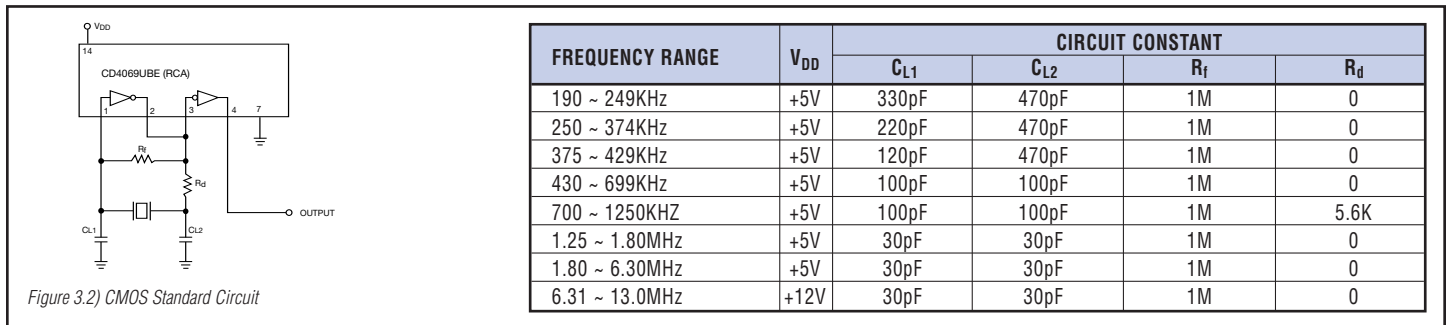
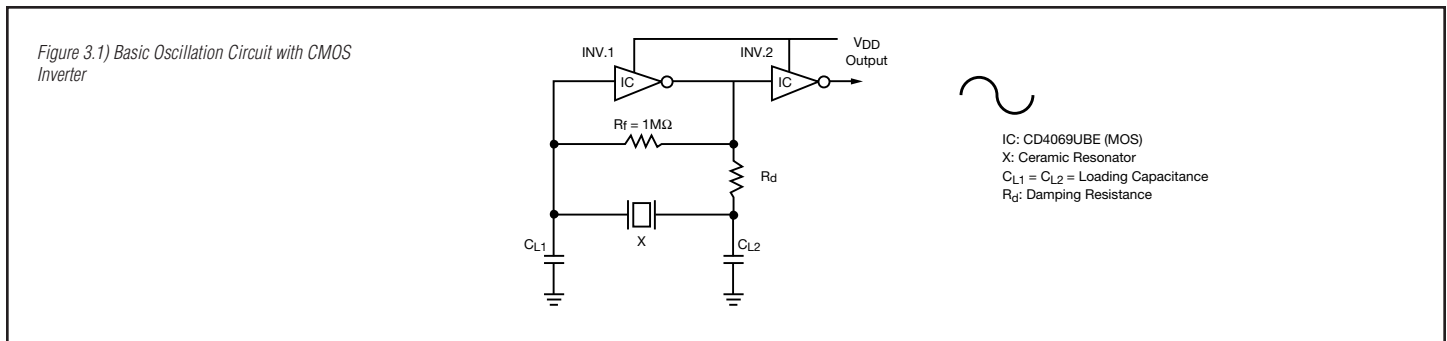

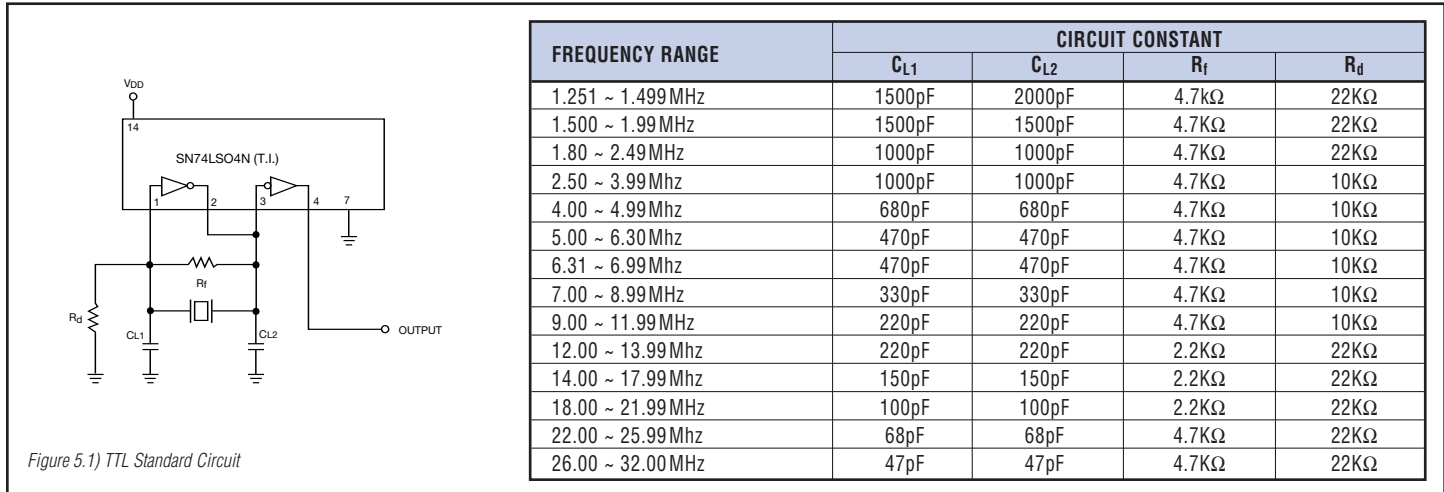

Figure 5.1) TTL Standard Circuit

Circuits for Various IC/LSI:

Ceramic resonators are being used in a wide range of applications in combination with various kinds of IC's by making good use of the previously mentioned features. Following are a few examples of actual applications.

Applications for Microprocessors: Ceramic resonators are optimum as a stable oscillating element for various kinds of microprocessors: 4 bit, 8 bit, and 16 bit. As the general frequency tolerance required for the reference clock of microprocessors is $\pm 2\%$ - 3% , standard units meet this requirement. Ask your ECS or LSI manufacturers about circuit constants because they vary with frequency and the LSI circuit being used. Fig. A shows an application with a 4 bit microprocessor, and Fig. B shows an application with an 8 bit microprocessor.

Remote Control IC: Remote controls have increasingly become a common feature. Oscillation frequency is normally 400-500 KHz, with 455KHz being the most popular. This 455KHz is divided by a carrier signal generator so that approximately 38KHz of carrier is generated.

VCO (Voltage Controlled Oscillator) Circuits: VCO circuits are used in TV's and audio equipment because the signals need to be processed in synchronization with pilot signals transmitted from broadcasting stations. Oscillation circuits, such as LC and RC were originally used; however, ceramic resonators are now used since they require no adjustment and have superior stability over the older type circuits. Resonators for VCO applications are required to have a wide variable frequency

Miscellaneous: Other than the above mentioned uses, ceramic resonators are widely used with IC's for voice synthesis and clock generation. For general timing control applications, oscillation frequency is usually selected by the user based on the IC manufacturer's recommended operating frequency range. The selection of this frequency with a given IC will dictate what circuit values and which ceramic resonator will be appropriate. Please contact your local ECS Sales representative when selecting a ceramic resonator part number.

As mentioned earlier, there are many applications for ceramic resonators. Some of the more application specific oscillator circuits require that unique ceramic resonators be developed for that application and IC.

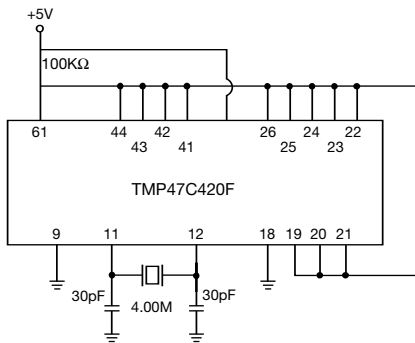

Figure A) TMP47C420F (TOSHIBA)

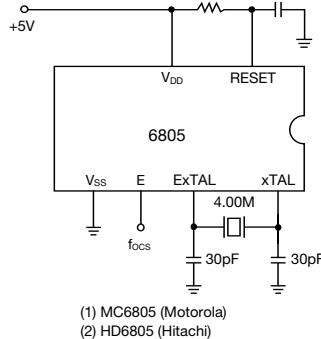

Figure B) 6805s by Various Manufacturers (Timing Control)

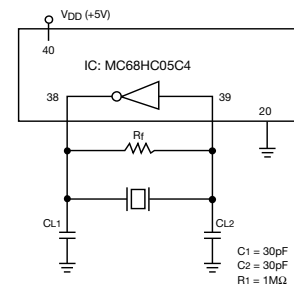

Figure C) By Various Manufacturers (Timing Control, 8bit)

OSCILLATION RISE TIME

Oscillation rise time means the time when oscillation develops from a transient area to a steady area at the time the power to the IC is activated. With a ceramic resonator, it is defined as the time to reach 90% of the oscillation level under steady conditions as shown in Fig. 6.1.

Rise time is primarily a function of oscillating circuit design. Generally, smaller loading capacitance, a higher frequency ceramic resonator, and a smaller size of ceramic resonator will cause a faster rise time. The effect of load capacitance becomes more apparent as the capacitance of the resonator decreases. Fig.6.2 shows an actual measurement of rise time

against load capacitance (C_L) and supply voltage. It is noteworthy that the rise time is one or two decades faster for a ceramic resonator than for a quartz crystal. (This point is graphically illustrated in Fig. 6.3)

Starting Voltage: Starting voltage means the minimum supply voltage at which an oscillating circuit can operate. Starting voltage is affected by all circuit elements. It is determined mostly by the characteristics of the IC. Fig. 6.4 shows an example of an actual measurement for the starting voltage characteristics against the loading capacitance.

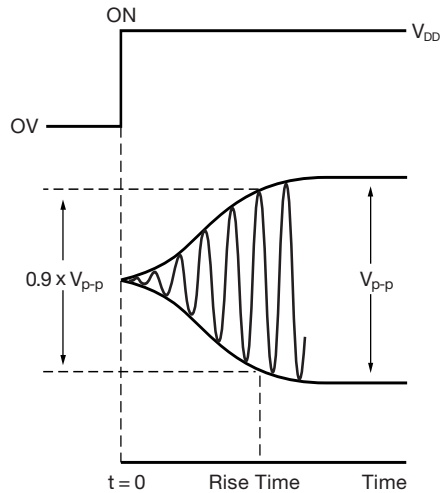
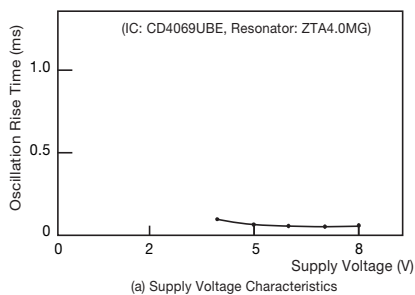
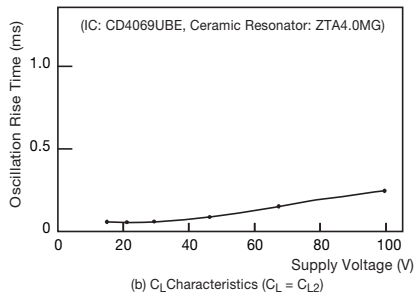

Figure 6.1) Definition of Rise Time



(a) Supply Voltage Characteristics



(b) C_L Characteristics ($C_L = C_{L2}$)

Figure 6.2) Example of Actual Measurements for the Charac. of Oscillation Rise Time

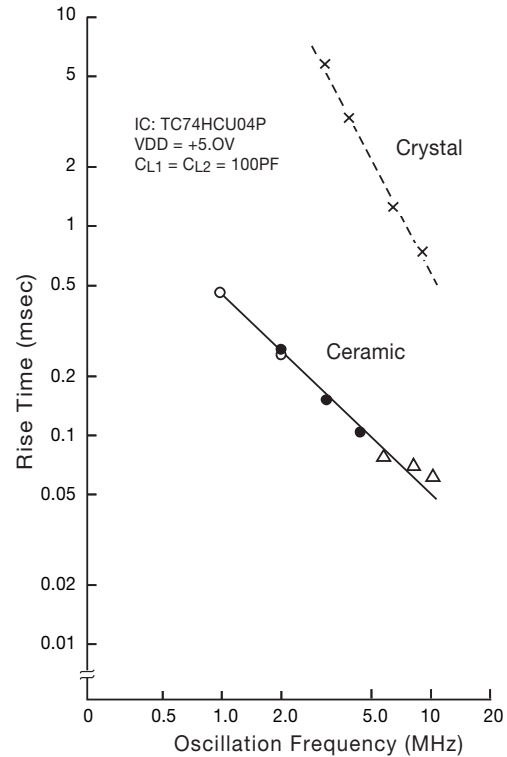

Figure 6.3) Rise Time vs. Oscillation Frequency for both Ceramic and Crystal Resonators

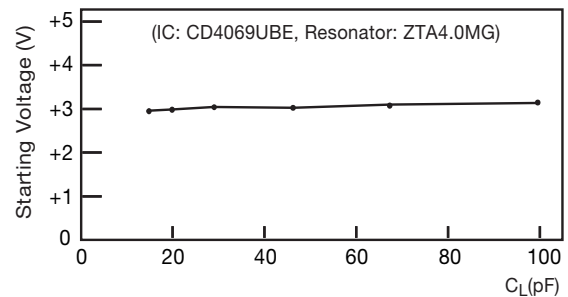

Figure 6.4) Starting Voltage Characteristics Against C_L ($C_{L1} = C_{L2}$)

CHARACTERISTICS OF CERAMIC RESONATOR OSCILLATION

The following describes the general characteristics of oscillation in the basic circuit. Contact ECS International for detailed characteristics of oscillation with specific kinds of IC's and LSI's.

The stability against temperature change is ± 0.3 to 0.5% within a range of -20°C to $+80^\circ\text{C}$, although it varies slightly depending on the ceramic material. Influences of load capacitance (C_{L1} , C_{L2}) on the oscillation frequency is relatively high as can be calculated from the formula for f_{OSC} . The f_{OSC} varies by approximately $\pm 0.1\%$ because of the capacitance deviation of $\pm 0.1\%$ in the working voltage range. The f_{OSC} also varies with the characteristics of the IC.

Supply Voltage Variation Characteristics: See Fig.1 below for an example of an actual measurement of stability for a given oscillation frequency.

Oscillation Level: Below are examples of actual measurements of the oscillation level against temperature, supply voltage, and load capacitance (C_{L1} , C_{L2}). The oscillating level is required to be stable over a wide temperature range, and temperature characteristics be as flat as possible. This change is linear with supply voltage unless the IC has an internal constant voltage power source.

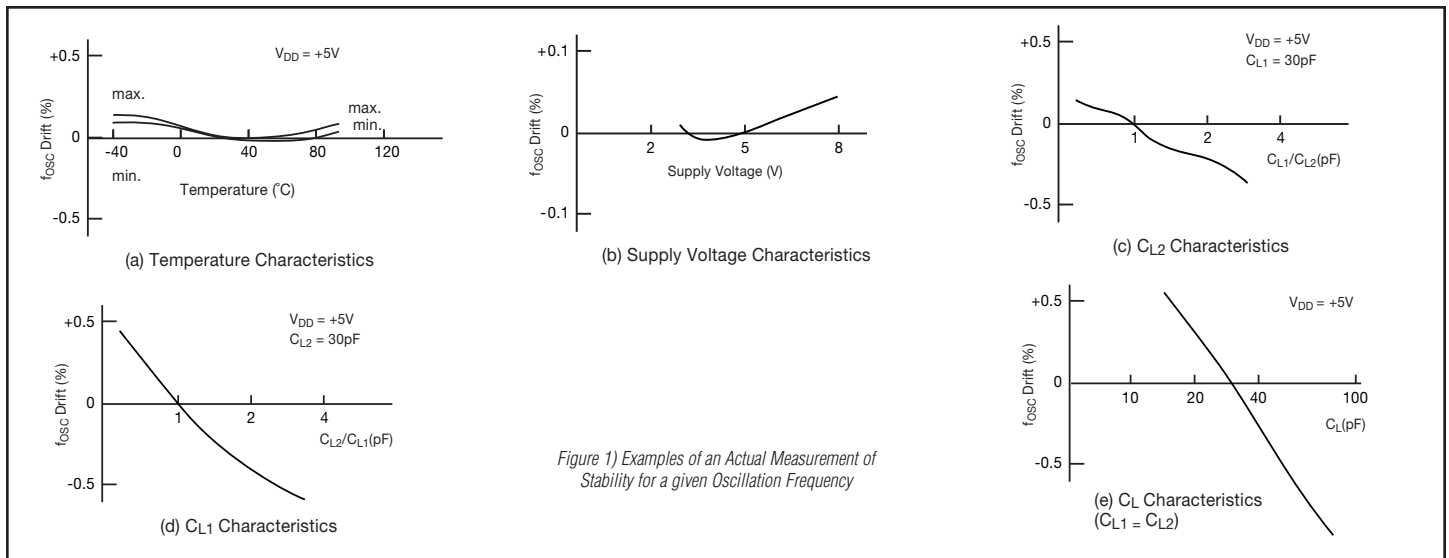

Figure 1) Examples of an Actual Measurement of Stability for a given Oscillation Frequency

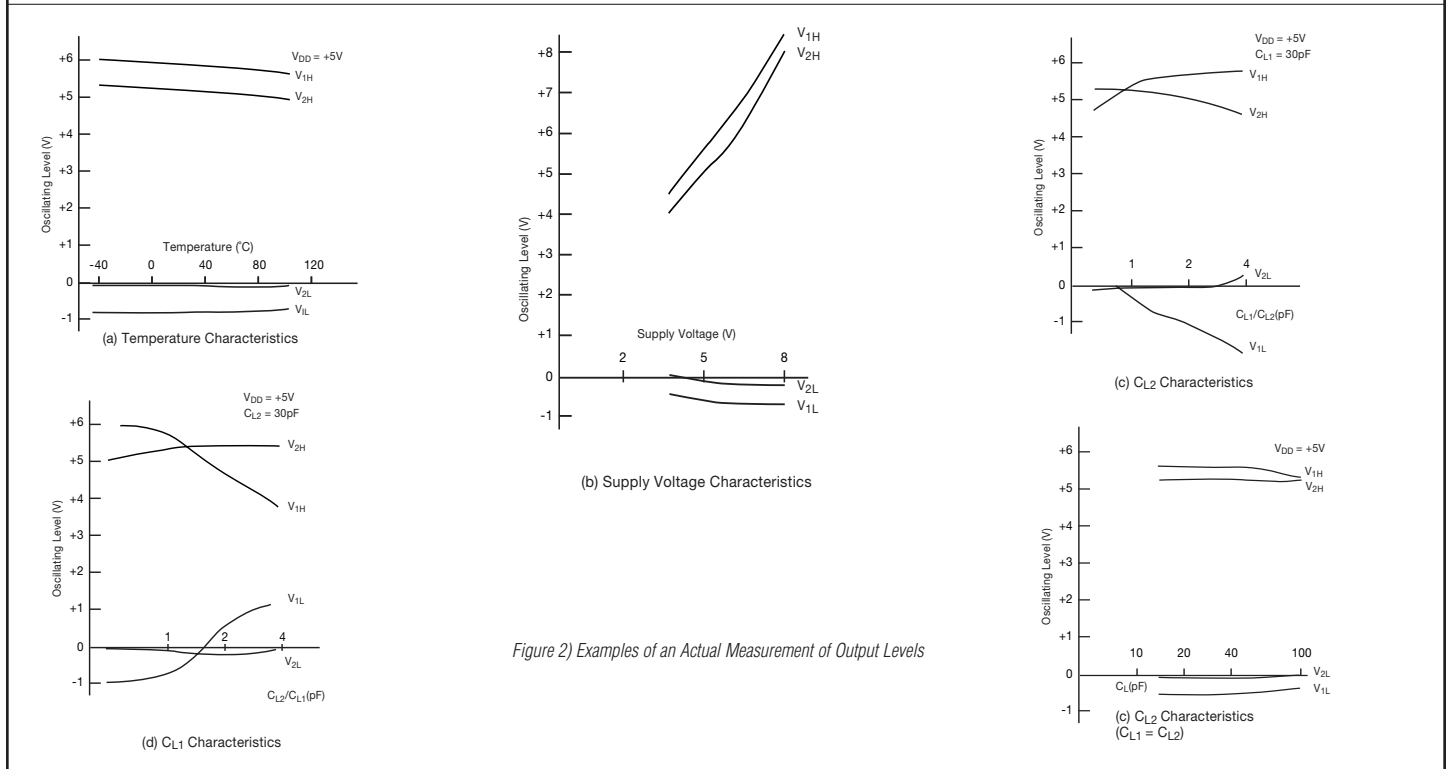

Figure 2) Examples of an Actual Measurement of Output Levels

With the rapid growth and increasing sophistication now taking place in all phases of the communication industry, there is a great demand for cost effective bandpass filters that offer state-of-the-art performance.

ECS has a wide offering of filters utilizing the following technologies:

- Monolithic Crystal Filters (MCF)
- Ceramic Filters
- Surface Acoustic Wave (SAW) Filters

These three technologies are utilized over the frequency range where they will offer a highly consistent performance and have exceptional long-term reliability at the lowest possible cost. Each technology offers certain advantages at the frequency range where they are used, additional information about each filter technology is discussed below. Be sure to familiarize yourself with the typical filter amplitude frequency response curve, which is shown below (Fig. 1).

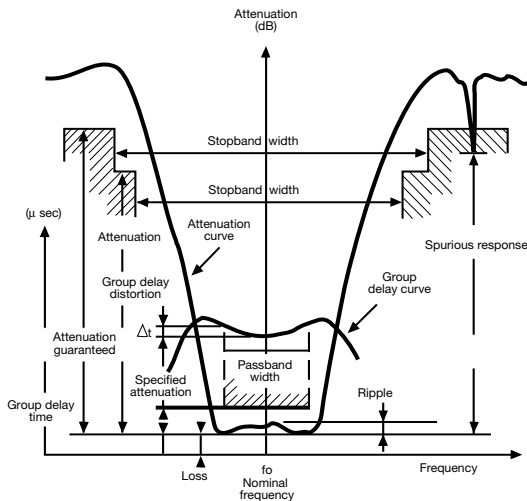

Figure 1)

Monolithic Crystal Filters (10.7 ~ 110MHz): Crystal Filters have very high Q's and excellent temperature and aging characteristics. These benefits result in filters that offer very narrow bandwidths and are highly selective.

The two-pole monolithic filter is the basis for all packaged crystal filters. Compared to a discrete crystal filter a single monolithic dual resonator replaces two discrete crystal units, a balanced transformer, and a trimmer capacitor. This results in a monolithic crystal filter being smaller and more cost effective than discrete crystal filters. MCF's use fewer components and have fewer interconnections so MCF's tend to be more reliable, while eliminating balanced transformers reduces loss and improves stability compared with discrete filters.

With the addition of coupling capacitors between two-pole sections, they can be cascaded to produce four, six and eight or more pole filter responses (see figure 2 & 3 for MCF Test Circuits).

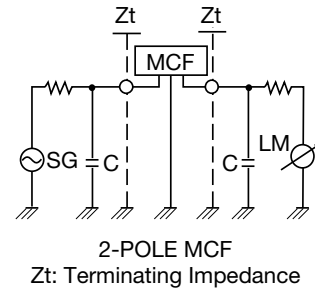

Figure 2)

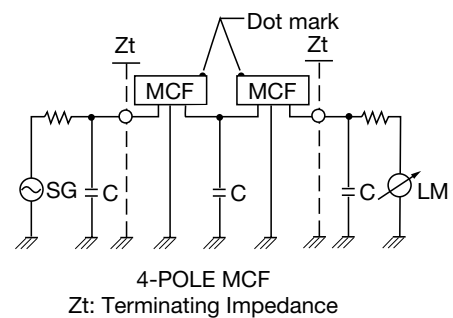

Figure 3)

The typical shape factor that can be achieved from a given number of poles with monotonic filters is shown below in Table 1).

NUMBER OF POLES	SHAPE FACTOR (60/3 dB)
2	30
4	5
6	2.5
8	1.9

Table 1)

There are two basic problems associated with crystal filters: spurious responses and non-linear drive level responses.

The spurious responses are caused by, anharmonic resonances normally occurring just above the desired resonance as well as near harmonic overtone responses. The spurious region appears in the filter as narrow responses of reduced attenuation.

The non-linear drive level response limits the drive level to a maximum of +10 dBm with a recommended drive level of -10 dBm Max. Unless the crystals are carefully designed and manufactured the Q and frequency can change as a function of drive and the Q could have as the drive level was changed from -10 to -60 dBm. Since MCF's must operate over a wide drive level ranges they should be tested over expected drive level conditions.

The non-linear drive condition is the main cause of intermodulation distortion (IMD) in crystal filters. IMD can be measured using the circuit shown in Fig. 4).

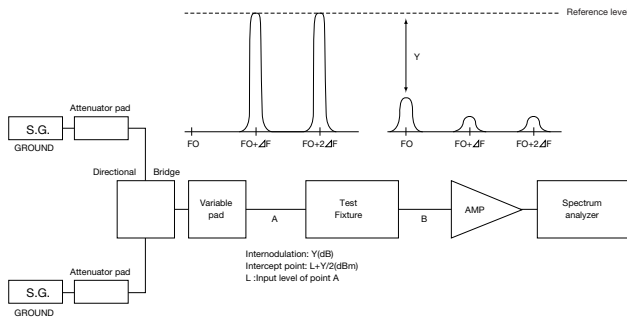

Figure 4)

ECS produces monolithic crystal filters for a wide range of uses, including narrow and intermediate band filters for mobile, UHF, and cordless telephones and single side band applications. ECS also offers several different package types including true SMD, surface mount (jacket type) and thru-hole monolithic crystal filters.

Ceramic Filters (450 KHz ~ 10.7): The most obvious advantage of a ceramic filter is the small size and lightweight for compact applications. These filters also have low loss, good waveform symmetry and high selectivity. All ceramic filters derive their basic frequency selectivity from mechanical vibration resulting from the piezoelectric effect. Since these devices are produced in large volumes they are very uniform which makes them ideal for large volume production designs.

Traditionally, nearly all low and high-end AM and FM commercial radios use ceramic bandpass filters. However, applications are also found in cordless telephones, cellular systems, 2-way communications, and the television industry. ECS, INC has been able to develop a complete line of practical, inexpensive ceramic filters for entertainment and communication applications.

It is imperative to properly match the impedance. Without the proper impedance matching, the operational characteristics of the ceramic filter can not be met. Figure 5 illustrates a typical test circuit. For instance if R1 and R2 are connected to lower values than specified, the insertion loss increases, the center frequency shifts towards the low side and the ripple increases. On the other hand if R1 and R2 are connected to a higher value than those specified, the insertion loss will increase, the center frequency will shift toward the high side and the ripple will increase.

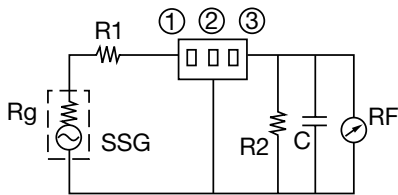

Figure 5)

It is also important to note that in designing circuits that ceramic filters are incapable of passing DC. In a typical circuit where a transistor is used a bias circuit will be required to drive the transistor. Since the ceramic filter requires matching resistance to operate properly, the matching resistor can play a dual role as both a matching and bias resistor.

If the bias circuit is used, it is important that the parallel circuit of both the bias resistance and the transistor's internal resistance be taken into consideration in meeting the resistance values. This is necessary since the internal resistance of the transistor is changed by the bias resistance. However, when an IC is used, there is no need for additional bias circuit since the IC has a bias circuit within itself.

Surface Acoustic Wave (SAW) Filters: (82-470MHz) There are many advantages to a SAW filter such as their compact package size which also results in a device that is very rugged. The fact that a SAW filter does not require tuning also means that it will not be de-tuned in the field thus making the device more reliable.

SAW filters are available at higher frequencies than MCF's and offer either narrow or wide bandwidths with very good selectivity.

Surface acoustic waves are mechanical (acoustic) rather than electromagnetic. In SAW devices, piezoelectric materials are required to convert the incoming electromagnetic signal to an acoustic one and then back to electromagnetic. The SAW filter is generally categorized as follows:

- Transversal type filter consisting of a pair of IDTs on a piezoelectric substrate (Fig. 6).
- Resonance type filter consisting of SAW resonators that are electrically or acoustically combined (Fig. 7 & 8).

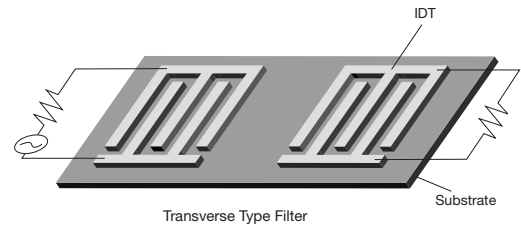

Figure 6)

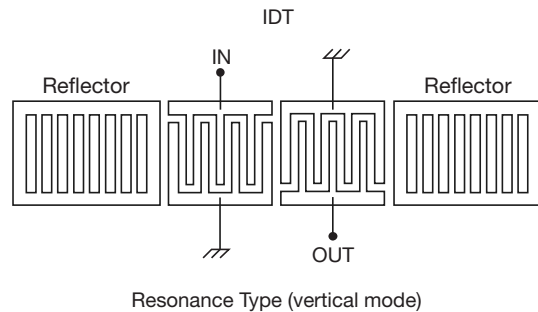
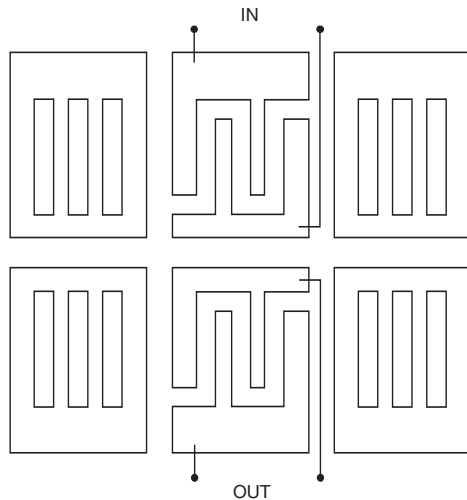

Figure 7)



Resonance Type (horizontal mode)

Figure 8) Resonance Type

Table 2) shows the major features of the two different type filters. The piezoelectric materials used to establish a SAW device are quartz crystals such as mono-crystals, or membranes of ZnO or similar substance.

FILTER TYPE	% BANDWIDTH	INSERTION LOSS
Transversal	0.3 ~ 30%	5 ~ 16
Resonance	0.02 ~ 0.3%	5 ~ 4

Table 2) Features of SAW Filters

At ECS INC, electrode configuration and substrates are selected according to the customer's requirements. Detailed design is conducted through computer simulation. These devices are generally used for a variety of RF/IF filters focused mainly on mobile communication applications such as pagers, portable phones, timing re-timing filters for optical communication, wireless local loop and spread spectrum communications.

Definitions

The following definitions will aid you in understanding filter performance for all types of filters.

Center Frequency (Fo): The arithmetic mean between the high and low cut off frequencies of a filter.

Bandwidth (BW): The difference between two cut off frequencies at a specified attenuation level (Usually 3 dB or 60 dB).

Attenuation: Reduction of signal in transmission through a filter. Attenuation is usually expressed in decibels (dB).

Decibel (dB): Unit that expresses the ration between two powers, two voltages or two currents.

$$\left(10 \text{ Log } \frac{P_1}{P_2}, 20 \text{ Log } \frac{V_1}{V_2} \text{ or } 20 \text{ Log } \frac{I_1}{I_2} \right)$$

Shape Factor (SF): Ratio of bandwidths at two different levels of attenuation.

Stop Band: The area of frequency where it is desirable to reject or attenuate all signals as much as practical. Also called reject band. Expressed as a range of frequencies attenuated by more than some specified minimum, such as 60 dB.

Ripple: The wavelike response in the passband of a filter (expressed in dB). Unless otherwise specified the maximum ripple will be that excursion from the highest peak to the lowest valley.

Insertion Loss (IL): Power loss of the filter in the passband (expressed in dB). Zero dB reference shall be the point of maximum output of the filter unless it is specified otherwise.

$$\text{Insertion Loss} = 10 \text{ Log } P_{in}/P_{out}$$

Source Impedance (Input Termination): The output impedance of the circuit that drives the filter.

Load Impedance (Output Termination): The impedance that must be connected to the output terminals of the filter in order to achieve the proper response.

Spurious Mode: Unwanted responses that occur in the filter due to resonant frequencies of the resonator other than the fundamental frequency.

RELIABILITY TEST PROCEDURES FOR QUARTZ CRYSTALS

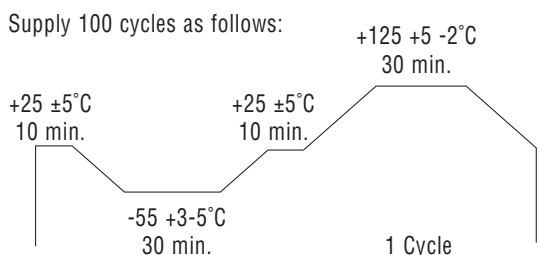
NO.	TEST NAME	TEST PROCEDURES	REQUIREMENTS
1	SHOCK	Drop 3 times from the height of 100 cm onto hard wooden board.	Frequency Drift ± 5 PPM Max. Resistance Drift $\pm 15\%$ Max.
2	VIBRATION	Vibration Frequency: 10 to 55 Hz, 1.5 mm, full wave Cycle: 2 min. Direction: X.Y.Z. Time: 2 hours in each direction	Frequency Drift ± 5 PPM Max. Resistance Drift $\pm 15\%$ Max.
3	SOLDERABILITY	After applying ROSIN flux, dip in solder Dipping Time: 3 ± 0.5 sec. Soldering Temperature: $+230 \pm 5$ °C Dipping Depth: 2 mm from the edge of terminals/lead-wires of specimen.	Over 90% of terminals/lead-wires dipped is covered by solder.
4	RESISTANCE TO SOLDERING HEAT	Dipping in solder Dipping Time: 10 ± 1 sec. Soldering Temperature: $+260 \pm 5$ °C Dipping Depth: 2 mm from the edge of terminals/lead-wires of specimen.	Frequency Drift ± 5 PPM Max. Resistance Drift $\pm 15\%$ Max.
5	STORAGE IN HIGH TEMPERATURE	$+85 \pm 2$ °C for 500 hours.	Frequency Drift ± 5 PPM Max. Resistance Drift $\pm 15\%$ Max.
6	STORAGE IN LOW TEMPERATURE	-40 ± 2 °C for 500 hours.	Frequency Drift ± 5 PPM Max. Resistance Drift $\pm 15\%$ Max.
7	HUMIDITY	$+60 \pm 2$ °C in humidity 95% for 500 hours.	Frequency Drift ± 5 PPM Max. Resistance Drift $\pm 15\%$ Max.
8	THERMAL SHOCK	Supply 500 cycles as follows: Temperature shift shall be done within 30 sec. $-55 \pm 2^{\circ}\text{C}$ (30 min) \longleftrightarrow $+125 \pm 2^{\circ}\text{C}$ (30 min)	Frequency Drift ± 5 PPM Max. Resistance Drift $\pm 15\%$ Max.
9	TEMPERATURE CYCLE	Supply 100 cycles as follows: 	Frequency Drift ± 5 PPM Max. Resistance Drift $\pm 15\%$ Max.

RELIABILITY TEST PROCEDURES FOR QUARTZ CRYSTALS

NO.	TEST NAME	TEST PROCEDURES	REQUIREMENTS
10	STRENGTH OF TERMINALS/ LEAD WIRES	1) Lead Pull Weight: 1 kg Time: 30 sec.	There are no visual abnormalities.
		2) Lead Bend Weight: 225 g Bending Angle: 90 degrees Bending Count: 2 times	There are no visual abnormalities.
11	SEALING TIGHTNESS MIL-STD 202F METHOD 112D TEST C AND D	1) Dipping in Florinert at: +125 ±5°C for 5 min. (Gross Leak)	There are no gas bubbles.
		2) Leak rate shall be measured by using: Helium Leak Detector (Fine Leak)	Leak rate: 1x10 ⁻⁶ atm°CC/sec. Max.

QUALITY ASSURANCE

Each factory has implemented exacting quality assurance standards to ensure consistent production of superior products. Manufacturing takes place in clean room environments and utilizes the latest in automated equipment, including several hundred assembly robots.

Through each process step all equipment and processes undergo rigorous inspection and testing. Combined with input from our worldwide sales force, this interaction has become a catalyst for many new product developments and refinements. Quality assurance is part of every employee ... every job ... every day so that the customer is completely satisfied with ECS products every time.

OVERVIEW

ECS design teams devote their talents to producing finished components of consistent quality, with superior aging characteristics. Because we know how replacement of failed components can impact your total operating costs, we recommend only sound, product designs that already meet ECS's exacting standards for performance and reliability.

Should any of our products not meet your expectations, let us know immediately. In most cases, a timely exchange of information can prevent unnecessary delays and expenses.

CARE AND HANDLING

All ECS frequency control products are hermetically sealed to protect against premature aging and ensure environmental stability. Refer to the product specifications in this catalog or consult your ECS sales representative to determine the best product for your application.

All sealed units require care in handling and mounting. Avoid excessive pressure to the pins. Do not bend wire leads tightly against the header. Care must be taken in soldering to the enclosure to keep temperatures low enough to avoid melting the internal crystal mounting structure. Failure to follow these precautions could result in damage to the seal and loss of the dry gas.

INSURANCE

ECS insures all shipments for the full value of the order unless otherwise specified by the customer in writing. Should your shipments be covered by your own insurance, we will purchase minimum coverage to guarantee traceability of your shipment. The cost of this coverage will be added to your charges.

TERMS

All shipments are made F.O.B. Olathe, Kansas, unless previously agreed to in writing by ECS, Inc. We will be happy to establish an open account for your company upon approval of your credit application. Please submit three references on your company letterhead with your application. For prompt shipment when a credit check could delay order processing, we suggest you enclose a company check with your order or request C.O.D. delivery.

WARRANTY

All ECS, Inc. products are warranted against defects in materials and workmanship for one year from the date of shipment to the original purchaser. The warranty is not transferrable and does not apply to cases of abuse, negligence or accident. All claims for damage in shipment should be made to the carrier; please advise us so we can verify your claim.

Return authorization and instructions must be obtained from the factory prior to a return shipment.

Returned goods should be shipped prepaid. If repairs are covered by warranty, we will pay all return shipping charges.

Returned goods should always be packaged carefully to avoid further damage. Examination of returned products helps us to prevent future problems.

ECS, Inc. shall, at our option, repair or replace any product which proves defective during the warranty period upon its return. ECS is not liable for consequential damages. No other warranty is expressed or implied.

This Product Catalog contains important information about our broad selection of Frequency Control Products. Its basic information should not be construed as a specification for every unit.

If you do not find the component you need listed here, please call ECS direct. We offer special product development and can design components to meet your specific requirements.

ECS makes no representation that the use or interconnection of the products described herein will not infringe on existing or future patent rights, nor do the descriptions contained herein imply the granting of licenses to make, use or sell equipment constructed in accordance therewith.

© 1998. ECS, Inc. All rights reserved. This catalog or any part or parts thereof, must not be reproduced in any form without permission of the copyright owner.

