

CMPA2060035F1

35 W, 2.0 - 6.0 GHz, GaN MMIC, Power Amplifier

Description

WolfSpeed's CMPA2060035F1 is a gallium nitride (GaN) high electron mobility transistor (HEMT) based monolithic microwave integrated circuit (MMIC). GaN has superior properties compared to silicon or gallium arsenide, including higher breakdown voltage, higher saturated electron drift velocity and higher thermal conductivity. GaN HEMTs also offer greater power density and wider bandwidths compared to Si and GaAs transistors. This MMIC contains a two-stage 50-ohm matched amplifier, enabling very wide bandwidths to be achieved, in a small 0.5" square, screw-down package.

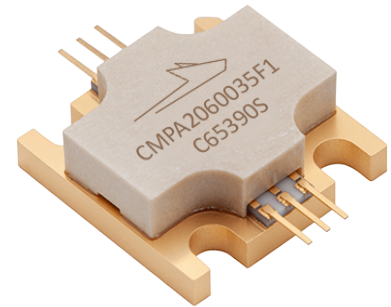

Package Types: 440219
PN's: CMPA2060035F1

Features

- >30% typical power added efficiency
- 30 dB small signal gain
- 36 W typical P_{SAT}
- Operation up to 28 V
- High breakdown voltage
- High temperature operation

Note:

Features represent typical performance across multiple frequencies under 25 °C operation. Please reference the performance charts for additional details.

Applications

- Civil and military pulsed radar amplifiers
- Test instrumentation
- Electronic warfare jamming

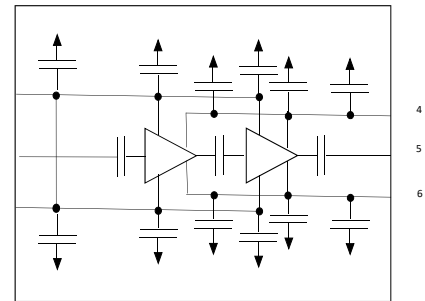

Typical Performance Over 2.0 - 6.0 GHz ($T_c = 25\text{ }^\circ\text{C}$)

Parameter	2.0 GHz	3.0 GHz	4.0 GHz	5.0 GHz	6.0 GHz	Units
Small Signal Gain ^{1,2}	30.0	29.4	30.4	32.0	27.5	dB
Output Power ^{1,3}	45.6	46.2	45.7	46.2	44.4	dBm
Power Gain ^{1,3}	23.6	24.2	23.7	24.2	22.4	dB
Power Added Efficiency ^{1,3}	52	48	38	35	30	%

Notes:

¹ $V_{DD} = 28\text{ V}$, $I_{DQ} = 1000\text{ mA}$.

²Measured at $P_{IN} = -20\text{ dBm}$.

³Measured at $P_{IN} = 22\text{ dBm}$ and CW.





Absolute Maximum Ratings (Not Simultaneous) at 25 °C

Parameter	Symbol	Rating	Units	Conditions
Drain-Source Voltage	V_{DSS}	84	V_{DC}	25 °C
Gate-Source Voltage	V_{GS}	-10, +2	V_{DC}	25 °C
Storage Temperature	T_{STG}	-55, +150	°C	
Maximum Forward Gate Current	I_G	16.32	mA	25 °C
Maximum Drain Current	I_{DMAX}	4.0	A	
Soldering Temperature	T_S	260	°C	

Electrical Characteristics (Frequency = 2.0 GHz to 6.0 GHz Unless Otherwise Stated; $T_c = 25\text{ °C}$)

Characteristics	Symbol	Min.	Typ.	Max.	Units	Conditions
DC Characteristics						
Gate Threshold Voltage	$V_{GS(TH)}$	-2.6	-2.0	-1.6	V	$V_{DS} = 10\text{ V}, I_D = 16.32\text{ mA}$
Gate Quiescent Voltage	$V_{GS(Q)}$	-	-1.8	-	V_{DC}	$V_{DD} = 28\text{ V}, I_{DQ} = 1000\text{ mA}$
Saturated Drain Current ¹	I_{DS}	16.32	19.58	-	A	$V_{DS} = 6.0\text{ V}, V_{GS} = 2.0\text{ V}$
Drain-Source Breakdown Voltage	V_{BD}	84	-	-	V	$V_{GS} = -8\text{ V}, I_D = 16.32\text{ mA}$
RF Characteristics						
Small Signal Gain	S_{21_1}	-	30.0	-	dB	$P_{IN} = -20\text{ dBm}, \text{Freq} = 2.0 - 6.0\text{ GHz}$
Output Power ²	P_{OUT1}	-	45.6	-	dBm	$V_{DD} = 28\text{ V}, I_{DQ} = 1000\text{ mA}, P_{IN} = 22\text{ dBm}, \text{Freq} = 2.0\text{ GHz}$
Output Power ²	P_{OUT2}	-	46.2	-	dBm	$V_{DD} = 28\text{ V}, I_{DQ} = 1000\text{ mA}, P_{IN} = 22\text{ dBm}, \text{Freq} = 3.0\text{ GHz}$
Output Power ²	P_{OUT3}	-	45.7	-	dBm	$V_{DD} = 28\text{ V}, I_{DQ} = 1000\text{ mA}, P_{IN} = 22\text{ dBm}, \text{Freq} = 4.0\text{ GHz}$
Output Power ²	P_{OUT4}	-	46.2	-	dBm	$V_{DD} = 28\text{ V}, I_{DQ} = 1000\text{ mA}, P_{IN} = 22\text{ dBm}, \text{Freq} = 5.0\text{ GHz}$
Output Power ²	P_{OUT5}	-	44.4	-	dBm	$V_{DD} = 28\text{ V}, I_{DQ} = 1000\text{ mA}, P_{IN} = 22\text{ dBm}, \text{Freq} = 6.0\text{ GHz}$
Power Added Efficiency ²	PAE_1	-	52	-	%	$V_{DD} = 28\text{ V}, I_{DQ} = 1000\text{ mA}, P_{IN} = 22\text{ dBm}, \text{Freq} = 2.0\text{ GHz}$
Power Added Efficiency ²	PAE_2	-	48	-	%	$V_{DD} = 28\text{ V}, I_{DQ} = 1000\text{ mA}, P_{IN} = 22\text{ dBm}, \text{Freq} = 3.0\text{ GHz}$
Power Added Efficiency ²	PAE_3	-	38	-	%	$V_{DD} = 28\text{ V}, I_{DQ} = 1000\text{ mA}, P_{IN} = 22\text{ dBm}, \text{Freq} = 4.0\text{ GHz}$
Power Added Efficiency ²	PAE_4	-	35	-	%	$V_{DD} = 28\text{ V}, I_{DQ} = 1000\text{ mA}, P_{IN} = 22\text{ dBm}, \text{Freq} = 5.0\text{ GHz}$
Power Added Efficiency ²	PAE_5	-	30	-	%	$V_{DD} = 28\text{ V}, I_{DQ} = 1000\text{ mA}, P_{IN} = 22\text{ dBm}, \text{Freq} = 6.0\text{ GHz}$
Power Gain	G_{P1}	-	23.6	-	dB	$V_{DD} = 28\text{ V}, I_{DQ} = 1000\text{ mA}, P_{IN} = 22\text{ dBm}, \text{Freq} = 2.0\text{ GHz}$
Power Gain	G_{P2}	-	24.2	-	dB	$V_{DD} = 28\text{ V}, I_{DQ} = 1000\text{ mA}, P_{IN} = 22\text{ dBm}, \text{Freq} = 3.0\text{ GHz}$
Power Gain	G_{P3}	-	23.7	-	dB	$V_{DD} = 28\text{ V}, I_{DQ} = 1000\text{ mA}, P_{IN} = 22\text{ dBm}, \text{Freq} = 4.0\text{ GHz}$
Power Gain	G_{P4}	-	24.2	-	dB	$V_{DD} = 28\text{ V}, I_{DQ} = 1000\text{ mA}, P_{IN} = 22\text{ dBm}, \text{Freq} = 5.0\text{ GHz}$
Power Gain	G_{P5}	-	22.4	-	dB	$V_{DD} = 28\text{ V}, I_{DQ} = 1000\text{ mA}, P_{IN} = 22\text{ dBm}, \text{Freq} = 6.0\text{ GHz}$
Input Return Loss	S11	-	-14	-	dB	$P_{IN} = -20\text{ dBm}, 2.0 - 6.0\text{ GHz}$
Output Return Loss	S22	-	-14	-	dB	$P_{IN} = -20\text{ dBm}, 2.0 - 6.0\text{ GHz}$
Output Mismatch Stress	VSWR	-	-	5:1	Ψ	No Damage at All Phase Angles

Notes:

¹ Scaled from PCM data.

² Performance is based on production testing at a fixed input power. To see performance where the input power is optimized for either maximum output power or power added efficiency, see Figures 46 and 47.



Thermal Characteristics

Parameter	Symbol	Rating	Units	Conditions
Operating Junction Temperature	T_J	225	°C	
Thermal Resistance, Junction to Case (Packaged) ¹	$R_{\theta JC}$	1.5	°C/W	CW

Note:

¹ For the CMPA2060035F1 at $P_{DISS} = 89$ W.



Typical Performance of the CMPA2060035F1

Test conditions unless otherwise noted: $V_D = 28\text{ V}$, $I_{DQ} = 1000\text{ mA}$, CW, $P_{IN} = 22\text{ dBm}$, $T_{BASE} = +25\text{ }^\circ\text{C}$

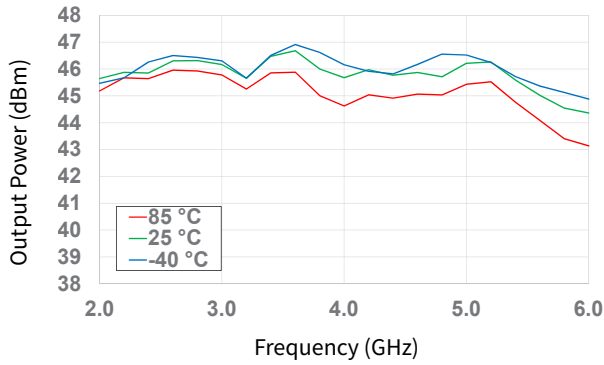

Figure 1. Output Power vs Frequency as a Function of Temperature

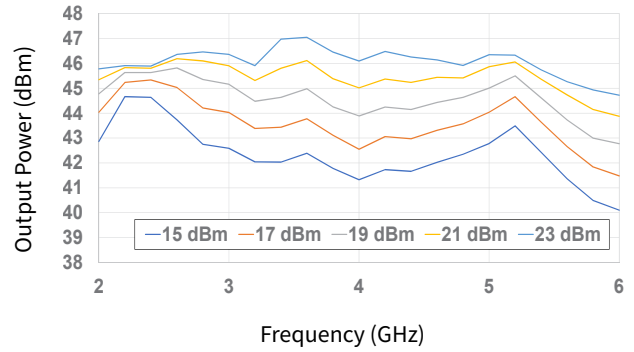

Figure 2. Output Power vs Frequency as a Function of Input Power

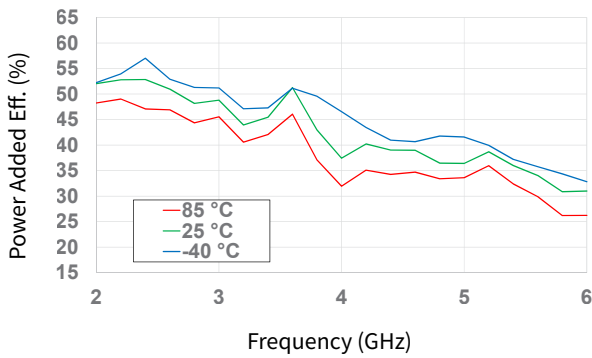

Figure 3. Power Added Eff. vs Frequency as a Function of Temperature

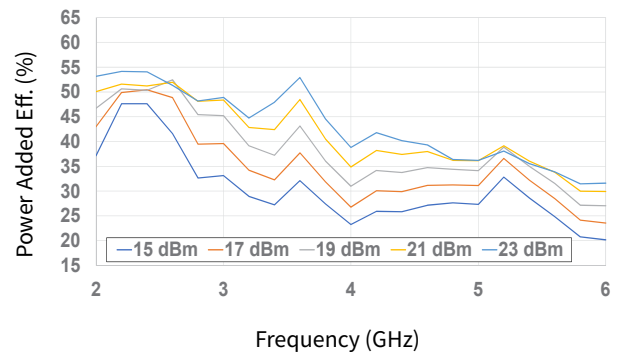

Figure 4. Power Added Eff. vs Frequency as a Function of Input Power

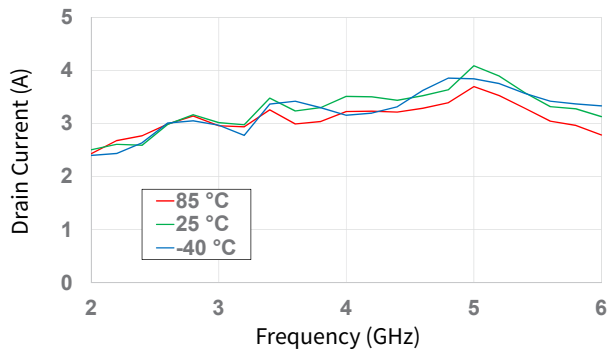

Figure 5. Drain Current vs Frequency as a Function of Temperature

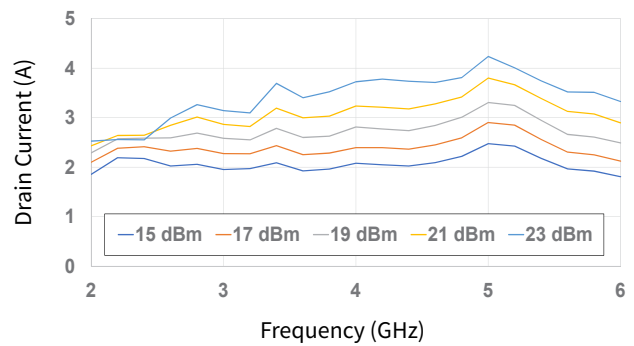

Figure 6. Drain Current vs Frequency as a Function of Input Power



Typical Performance of the CMPA2060035F1

Test conditions unless otherwise noted: $V_D = 28\text{ V}$, $I_{DQ} = 1000\text{ mA}$, CW, $P_{IN} = 22\text{ dBm}$, $T_{BASE} = +25\text{ }^\circ\text{C}$

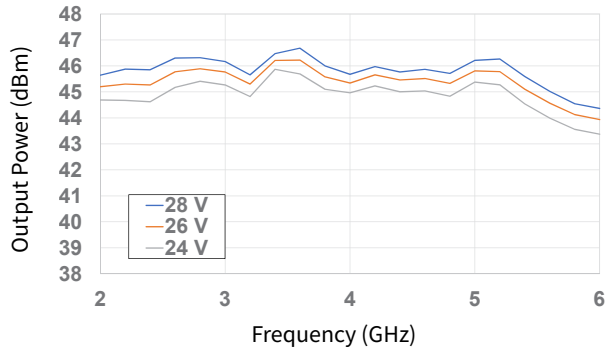

Figure 7. Output Power vs Frequency as a Function of V_D

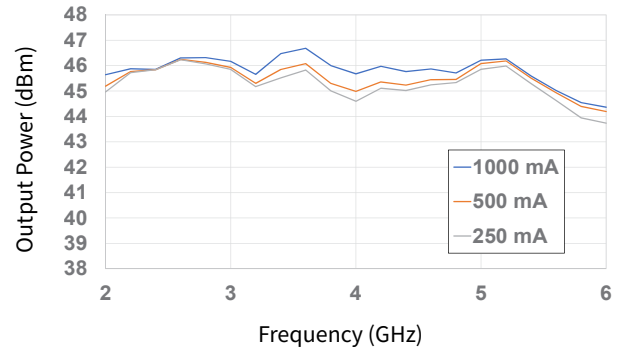

Figure 8. Output Power vs Frequency as a Function of I_{DQ}

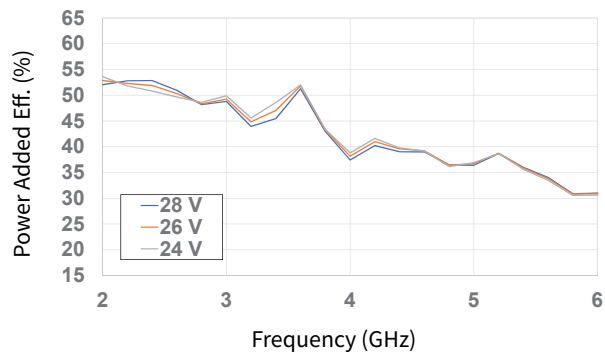

Figure 9. Power Added Eff. vs Frequency as a Function of V_D

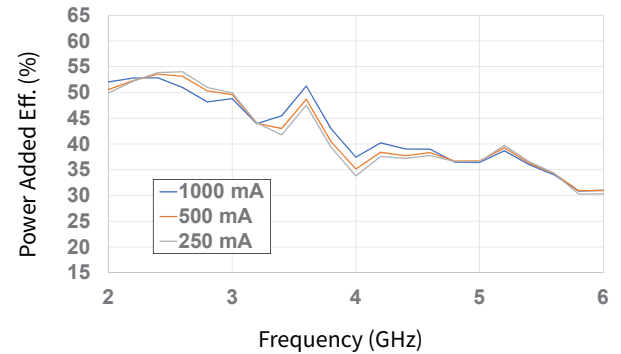

Figure 10. Power Added Eff. vs Frequency as a Function of I_{DQ}

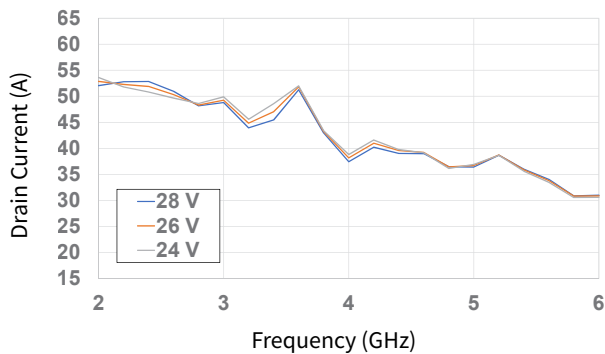

Figure 11. Drain Current vs Frequency as a Function of V_D

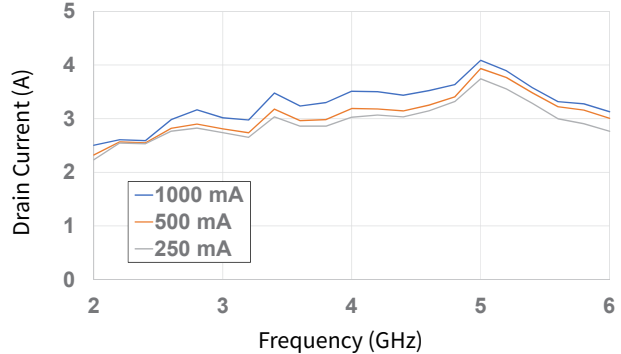

Figure 12. Drain Current vs Frequency as a Function of I_{DQ}



Typical Performance of the CMPA2060035F1

Test conditions unless otherwise noted: $V_D = 28\text{ V}$, $I_{DQ} = 1000\text{ mA}$, CW, $P_{IN} = 22\text{ dBm}$, $T_{BASE} = +25\text{ }^\circ\text{C}$

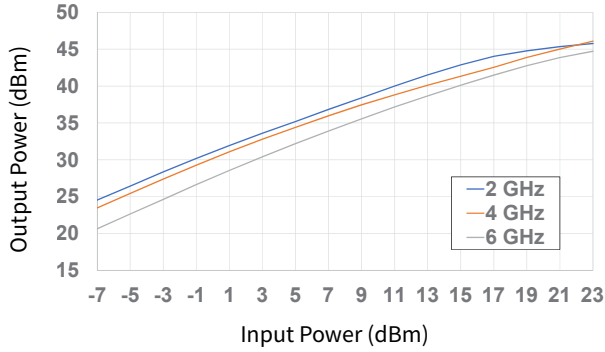

Figure 13. Output Power vs Input Power as a Function of Frequency

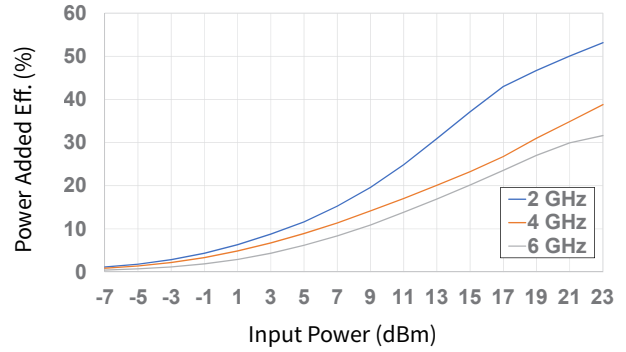

Figure 14. Power Added Eff. vs Input Power as a Function of Frequency

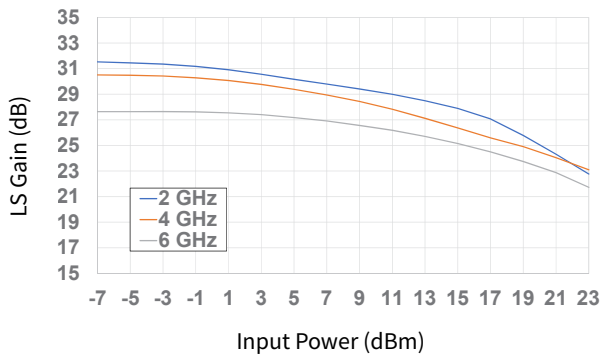

Figure 15. Large Signal Gain vs Input Power as a Function of Frequency

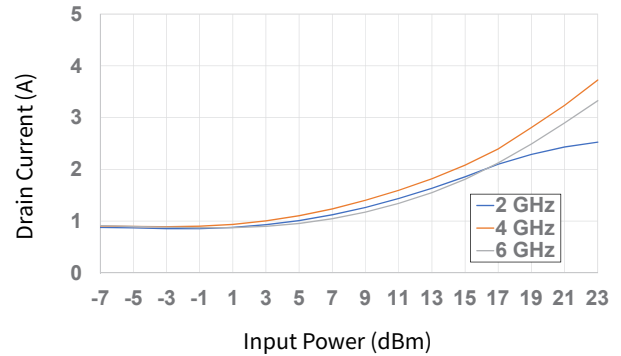

Figure 16. Drain Current vs Input Power as a Function of Frequency

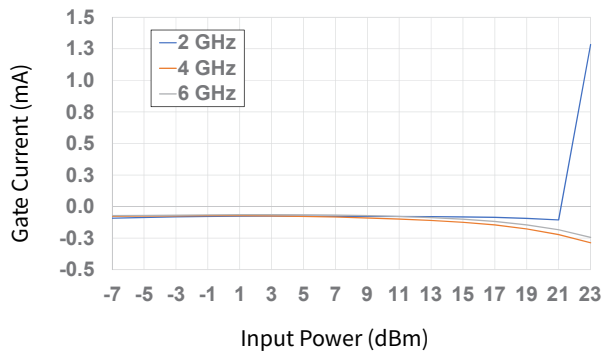

Figure 17. Gate Current vs Input Power as a Function of Frequency

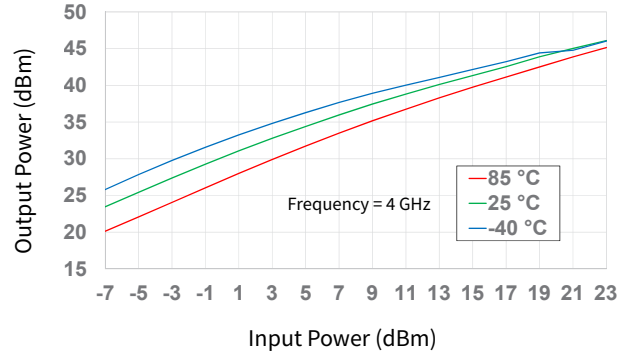

Figure 18. Output Power vs Input Power as a Function of Temperature



Typical Performance of the CMPA2060035F1

Test conditions unless otherwise noted: $V_D = 28\text{ V}$, $I_{DQ} = 1000\text{ mA}$, CW, $P_{IN} = 22\text{ dBm}$, $T_{BASE} = +25\text{ }^\circ\text{C}$

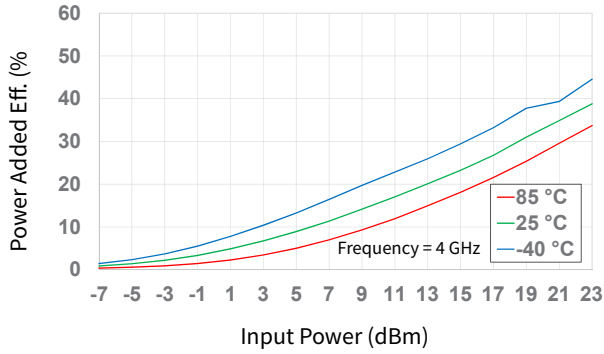

Figure 19. Power Added Eff. vs Input Power as a Function of Temperature

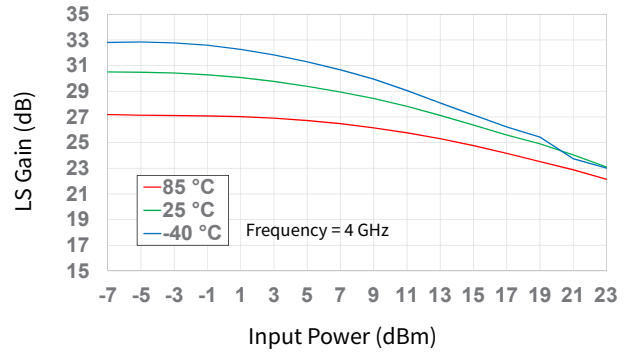

Figure 20. Large Signal Gain vs Input Power as a Function of Temperature

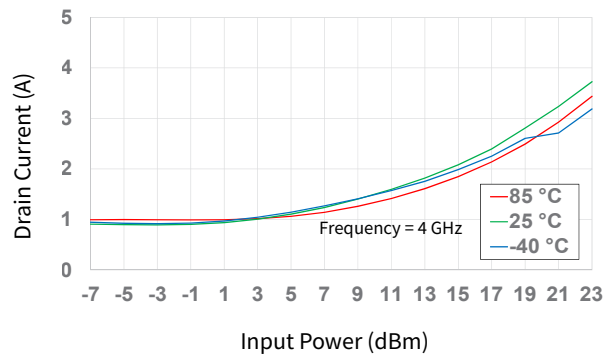

Figure 21. Drain Current vs Input Power as a Function of Temperature

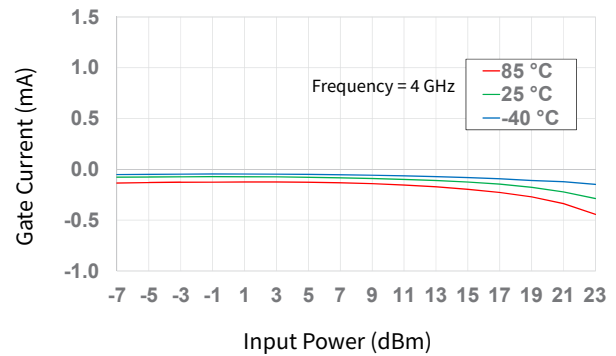

Figure 22. Gate Current vs Input Power as a Function of Temperature

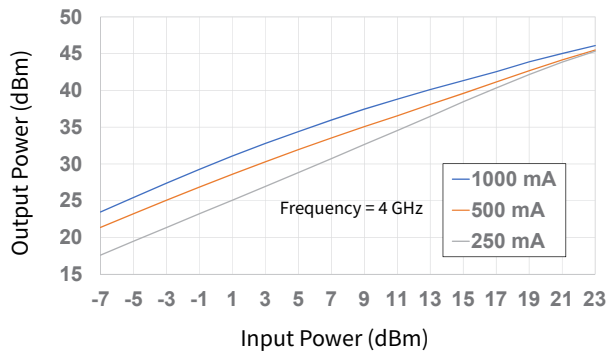

Figure 23. Output Power vs Input Power as a Function of I_{DQ}

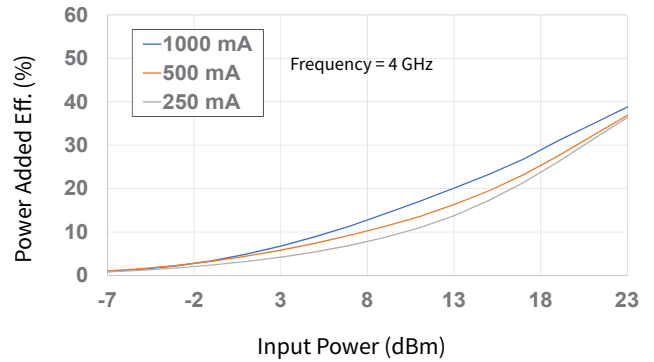

Figure 24. Power Added Eff. vs Input Power as a Function of I_{DQ}



Typical Performance of the CMPA2060035F1

Test conditions unless otherwise noted: $V_D = 28\text{ V}$, $I_{DQ} = 1000\text{ mA}$, CW, $P_{IN} = 22\text{ dBm}$, $T_{BASE} = +25\text{ }^\circ\text{C}$

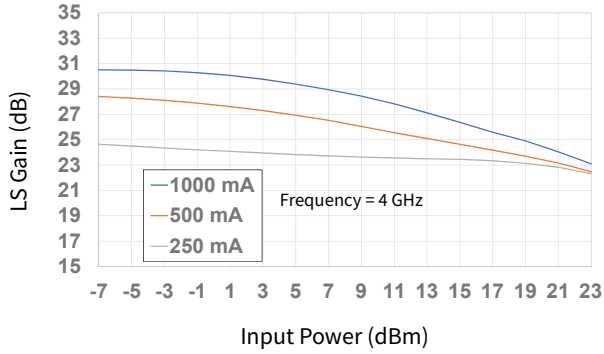

Figure 25. Large Signal Gain vs Input Power as a Function of I_{DQ}

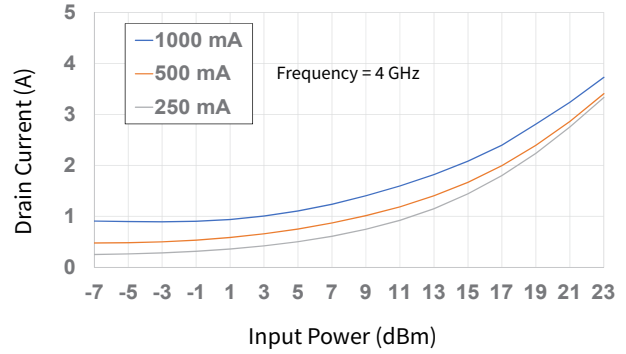

Figure 26. Drain Current vs Input Power as a Function of I_{DQ}

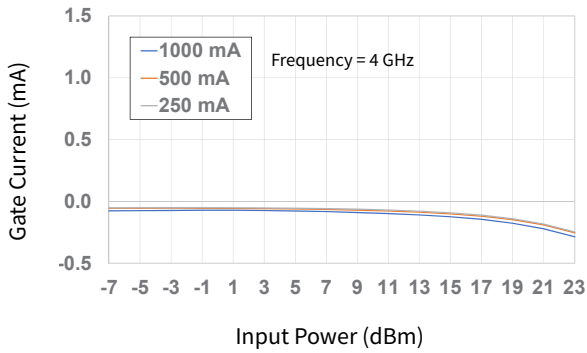

Figure 27. Gate Current vs Input Power as a Function of I_{DQ}

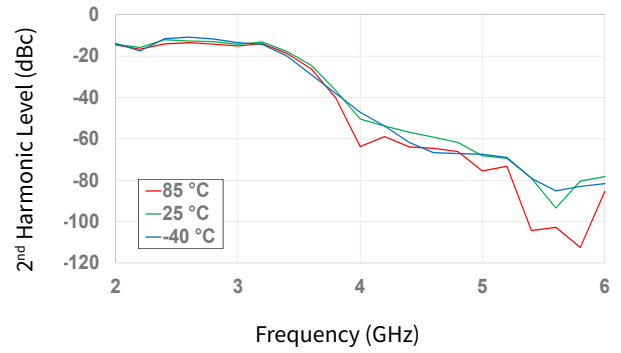

Figure 28. 2nd Harmonic vs Frequency as a Function of Temperature

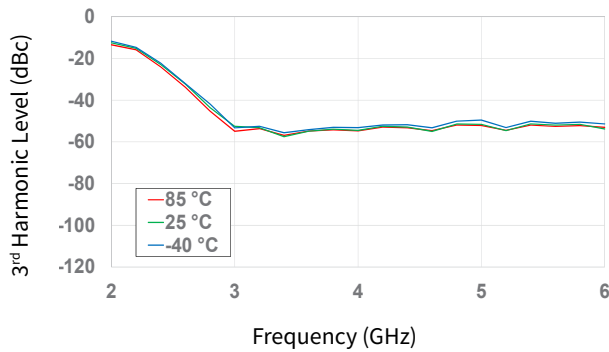

Figure 29. 3rd Harmonic vs Frequency as a Function of Temperature

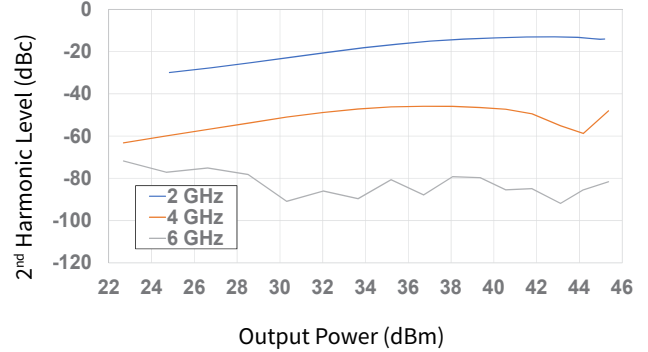

Figure 30. 2nd Harmonic vs Output Power as a Function of Frequency



Typical Performance of the CPMA2060035F1

Test conditions unless otherwise noted: $V_D = 28\text{ V}$, $I_{DQ} = 1000\text{ mA}$, CW, $P_{IN} = 22\text{ dBm}$, $T_{BASE} = +25\text{ }^\circ\text{C}$

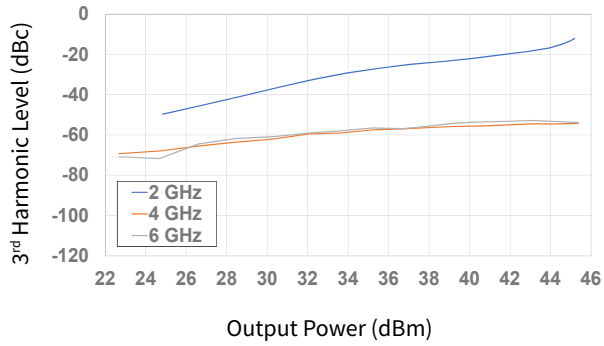

Figure 31. 3rd Harmonic vs Output Power as a Function of Frequency

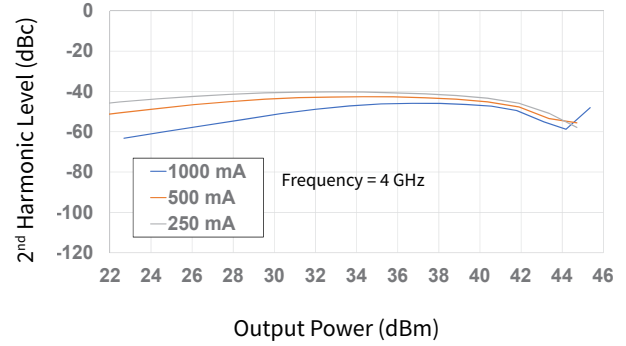

Figure 32. 2nd Harmonic vs Output Power as a Function of I_{DQ}

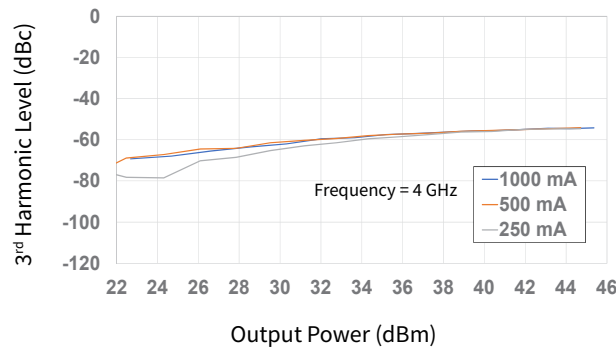

Figure 33. 3rd Harmonic vs Output Power as a Function of I_{DQ}



Typical Performance of the CPMA2060035F1

Test conditions unless otherwise noted: $V_D = 28\text{ V}$, $I_{DQ} = 1000\text{ mA}$, $P_{IN} = -20\text{ dBm}$, $T_{BASE} = +25\text{ }^\circ\text{C}$

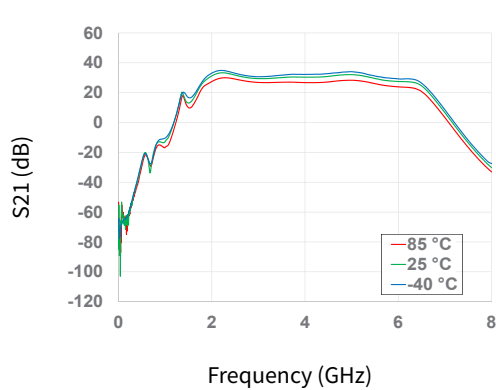

Figure 34. Gain vs Frequency as a Function of Temperature

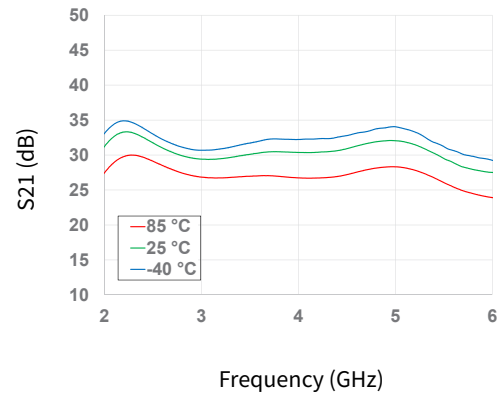

Figure 35. Gain vs Frequency as a Function of Temperature

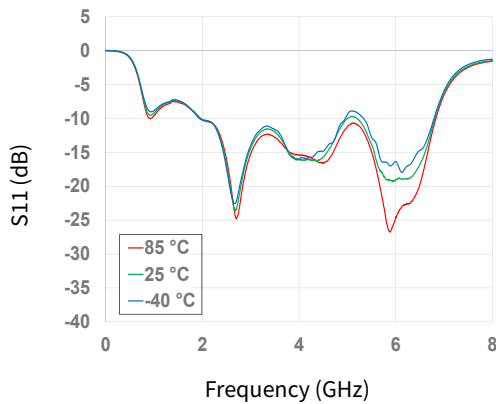

Figure 36. Input RL vs Frequency as a Function of Temperature

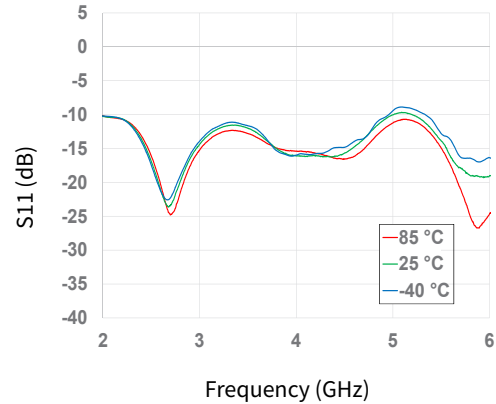

Figure 37. Input RL vs Frequency as a Function of Temperature

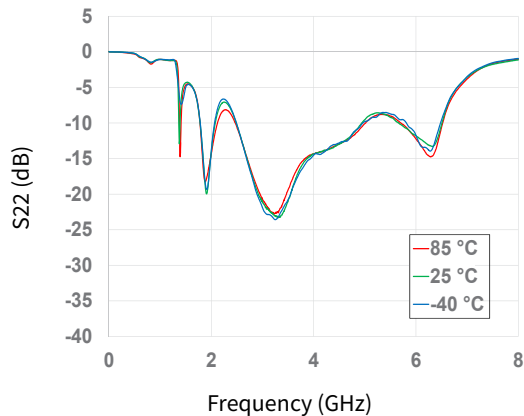

Figure 38. Output RL vs Frequency as a Function of Temperature

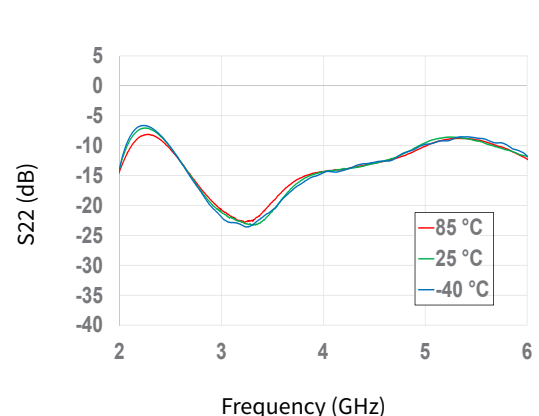

Figure 39. Output RL vs Frequency as a Function of Temperature



Typical Performance of the CMPA2060035F1

Test conditions unless otherwise noted: $V_D = 28\text{ V}$, $I_{DQ} = 1000\text{ mA}$, $P_{IN} = -20\text{ dBm}$, $T_{BASE} = +25\text{ }^\circ\text{C}$

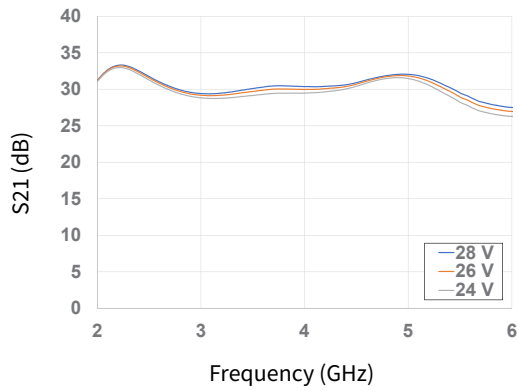

Figure 40. Gain vs Frequency as a Function of Voltage

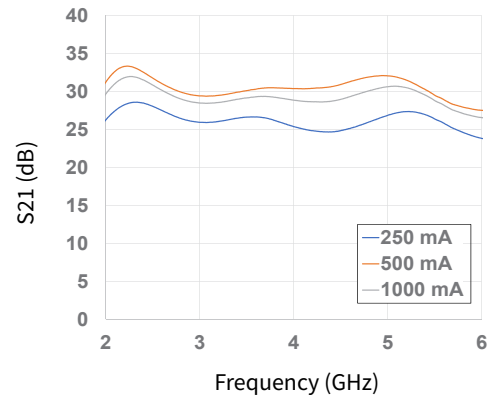

Figure 41. Gain vs Frequency as a Function of Voltage

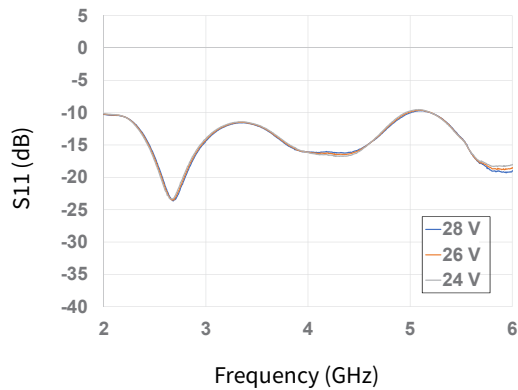

Figure 42. Input RL vs Frequency as a Function of Voltage

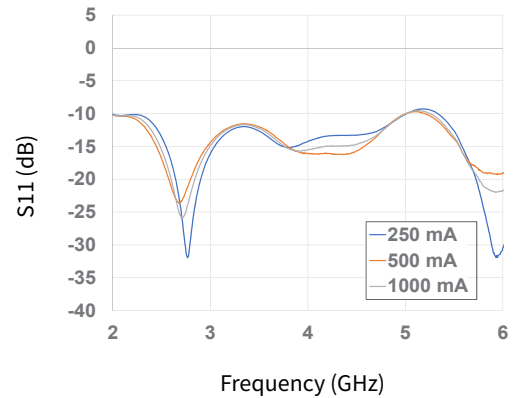

Figure 43. Input RL vs Frequency as a Function of I_{DQ}

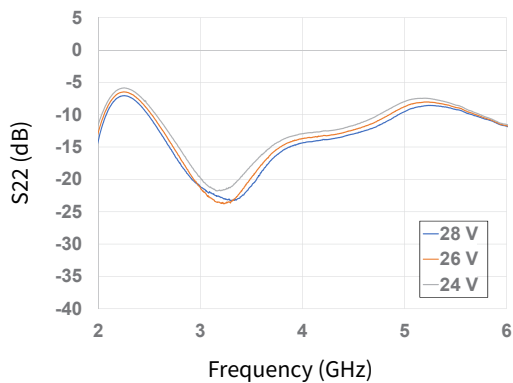

Figure 44. Output RL vs Frequency as a Function of Voltage

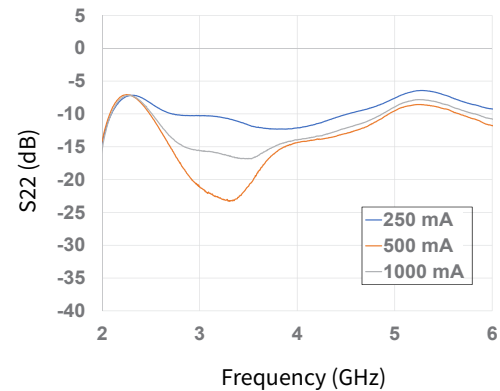

Figure 45. Output RL vs Frequency as a Function of I_{DQ}



Typical Performance of the CPM2060035F1

Test conditions unless otherwise noted: $V_D = 28\text{ V}$, $I_{DQ} = 1000\text{ mA}$, $P_{IN} = -20\text{ dBm}$, $T_{BASE} = +25\text{ }^\circ\text{C}$

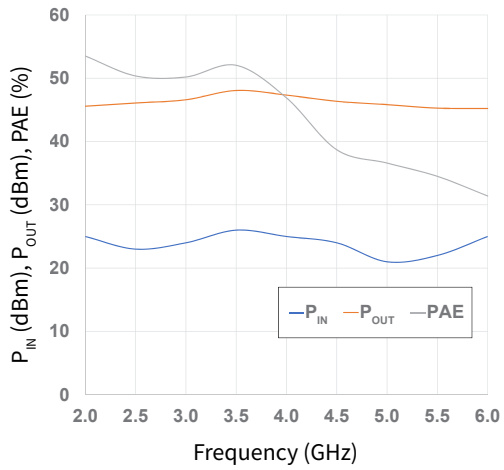

Figure 46. Output Power and Power Added Eff. vs Frequency when Optimized for Maximum PAE

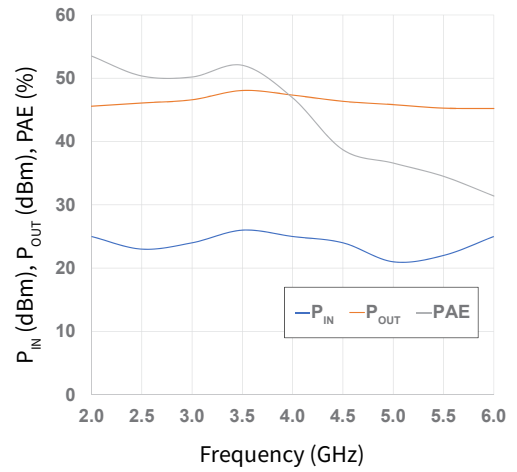
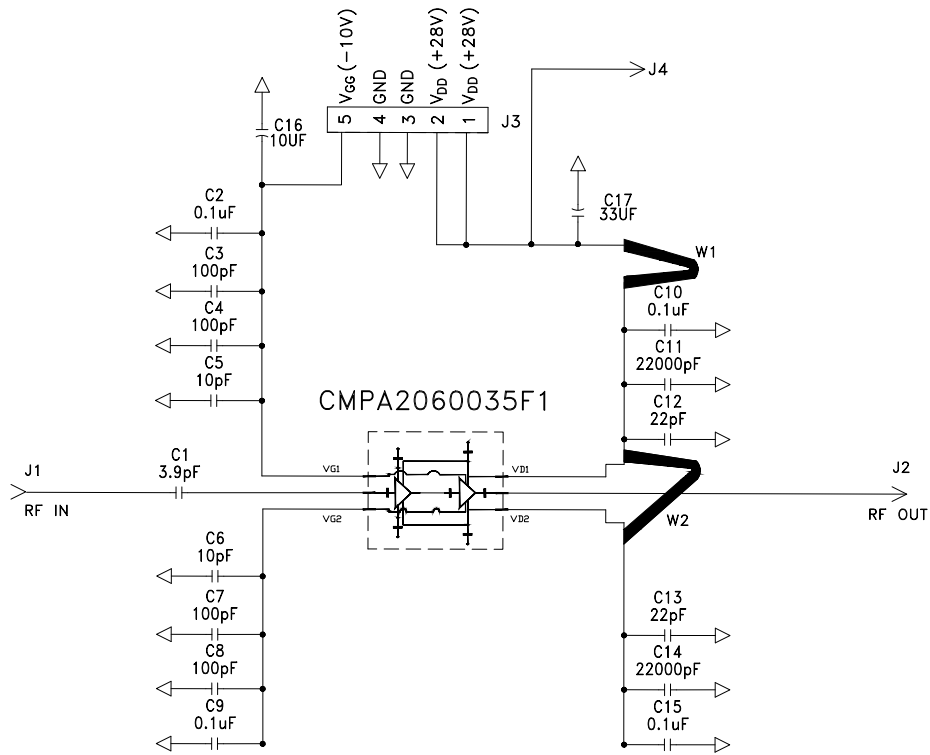

Figure 47. Output Power and Power Added Eff. vs Frequency when Optimized for Maximum Output Power



CMPA2060035F1-AMP Evaluation Board Schematic



CMPA2060035F1-AMP Evaluation Board Outline

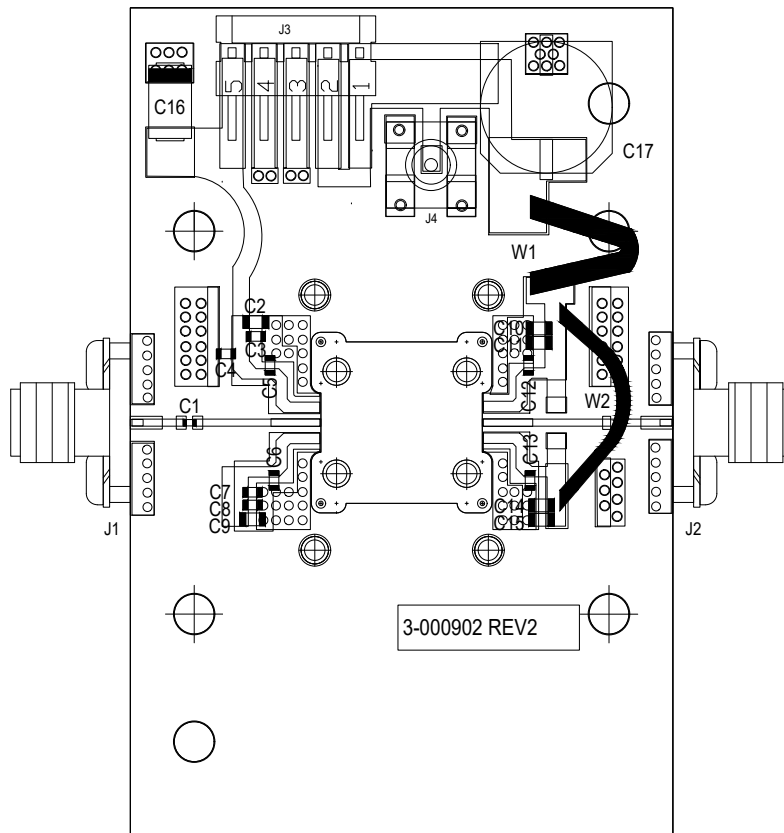



CMPA2060035F1-AMP Evaluation Board Bill of Materials

Designator	Description	Qty
C1	CAP, 3.9 pF, +/-0.1 pF, 0402, ATC	1
C11, C14	CAP CER 22,000 PF 100 V 10% X7R 0805	2
C12, C13	CAP, 22 pF,+/-5%, 0603, ATC	2
C16	CAP 10 UF 16 V TANTALUM, 2312	1
C17	CAP, 33 UF, 20%, G CASE	1
C2, C9, C10, C15	CAP CER 0.1 UF 100 V 10% X7R 0805	4
C3, C4, C7, C8	CAP, 100.0 pF, +/-5%, 0603, ATC	4
C5, C6	CAP, 10.0 pF, +/-5%, 0603, ATC	2
J1, J2	CONN, SMA, PANEL MOUNT JACK, FLANGE, 4-HOLE, BLUNT POST, 20 MIL	2
J3	HEADER RT>PLZ .1CEN LK 5POS	1
J4	CONN, SMB, STRAIGHT JACK RECEPTACLE, SMT, 50 OHM, Au PLATED	1
W1, W2	WIRE, BLACK, 22 AWG	2
	TEST FIXTURE, 2-6 GHz, CMPA2060035F1	1
	PCB board 2.6" X 1.7", TACONIC RF 35, 0.01", 440219 Package	1
	BASEPLATE, AL, 2.60 X 1.70 X 2.50	1
Q1	CMPA2060035F1: GaN, MMIC PA, 35 W, 2-6 GHz, Flange	1

Electrostatic Discharge (ESD) Classifications

Parameter	Symbol	Class	Test Methodology
Human Body Model	HBM	1 B (≥ 500 V)	JEDEC JESD22 A114-D
Charge Device Model	CDM	II (≥ 200 V)	JEDEC JESD22 C101-C



Product Dimensions CMPA2060035F1 (Package 440219)

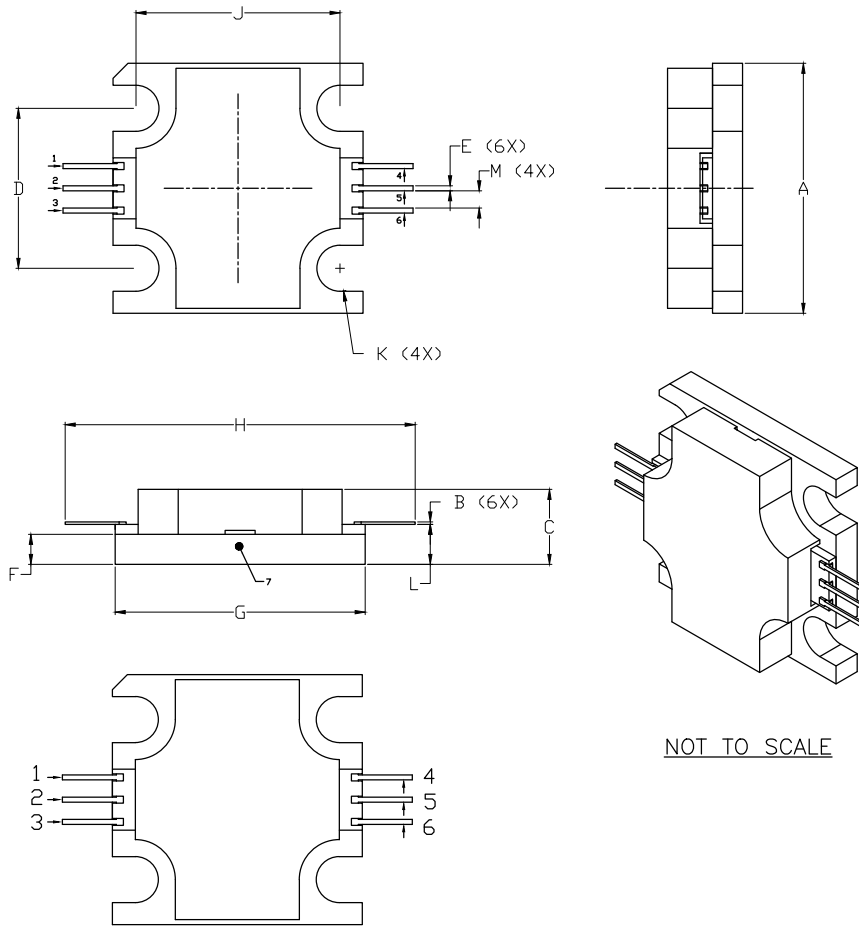

DIM	INCHES		MILLIMETERS	
	MIN	MAX	MIN	MAX
A	0.495	0.505	12.57	12.82
B	0.003	0.005	0.076	0.127
C	0.140	0.160	3.56	4.06
D	0.315	0.325	8.00	8.25
E	0.008	0.012	0.204	0.304
F	0.055	0.065	1.40	1.65
G	0.495	0.505	12.57	12.82
H	0.695	0.705	17.65	17.91
J	0.403	0.413	10.24	10.49
K	∅ .092		2.34	
L	0.075	0.085	1.905	2.159
M	0.032	0.040	0.82	1.02

Pin	Desc.
1	Gate 1
2	RF_IN
3	Gate 2
4	Drain 1
5	RF_OUT
6	Drain 2



Part Number System

CMPA2060035F1

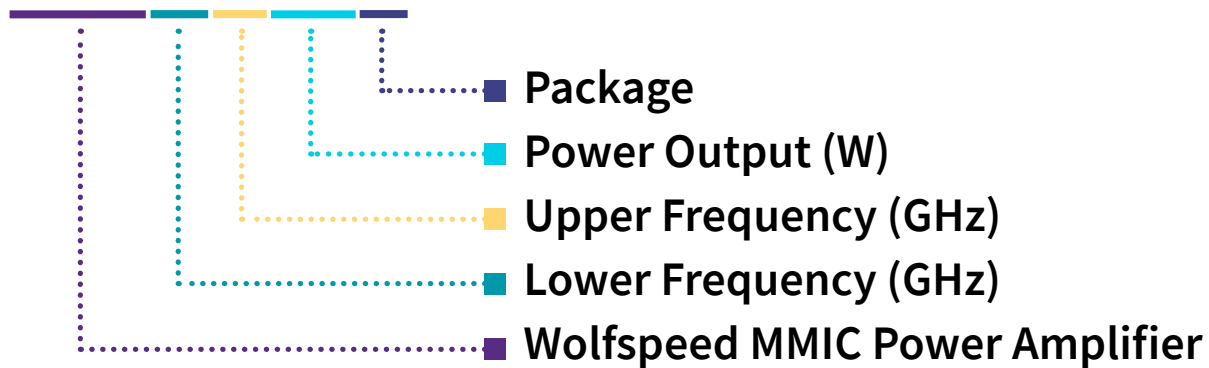

Table 1.

Parameter	Value	Units
Lower Frequency	2.0	GHz
Upper Frequency	6.0	GHz
Power Output	35	W
Package	Flange	-

Note:
Alpha characters used in frequency code indicate a value greater than 9.9 GHz. See Table 2 for value.

Table 2.

Character Code	Code Value
A	0
B	1
C	2
D	3
E	4
F	5
G	6
H	7
J	8
K	9
Examples:	1 A = 10.0 GHz 2 H = 27.0 GHz

Product Ordering Information

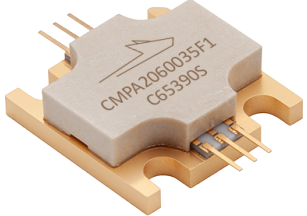
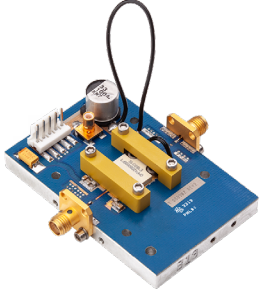
Order Number	Description	Unit of Measure	Image
CMPA2060035F1	GaN HEMT	Each	
CMPA2060035F1-AMP	Test Board with GaN MMIC Installed	Each	

**For more information, please contact:**

4600 Silicon Drive
Durham, NC 27703 USA
Tel: +1.919.313.5300
www.wolfspeed.com/RF

Sales Contact
RFSales@wolfspeed.com

RF Product Marketing Contact
RFMarketing@wolfspeed.com

Notes & Disclaimer

Specifications are subject to change without notice. “Typical” parameters are the average values expected by Wolfspeed in large quantities and are provided for information purposes only. Wolfspeed products are not warranted or authorized for use as critical components in medical, life-saving, or life-sustaining applications, or other applications where a failure would reasonably be expected to cause severe personal injury or death. No responsibility is assumed by Wolfspeed for any infringement of patents or other rights of third parties which may result from use of the information contained herein. No license is granted by implication or otherwise under any patent or patent rights of Wolfspeed.

© 2020-2023 Wolfspeed, Inc. All rights reserved. Wolfspeed® and the Wolfstreak logo are registered trademarks and the Wolfspeed logo is a trademark of Wolfspeed, Inc.
PATENT: <https://www.wolfspeed.com/legal/patents>

The information in this document is subject to change without notice.