

3M™ FOUR-WALL HEADER, 2500 SERIES

.100" X .100" LOW PROFILE, SURFACE MOUNT, STRAIGHT AND RIGHT ANGLE THROUGH-HOLE

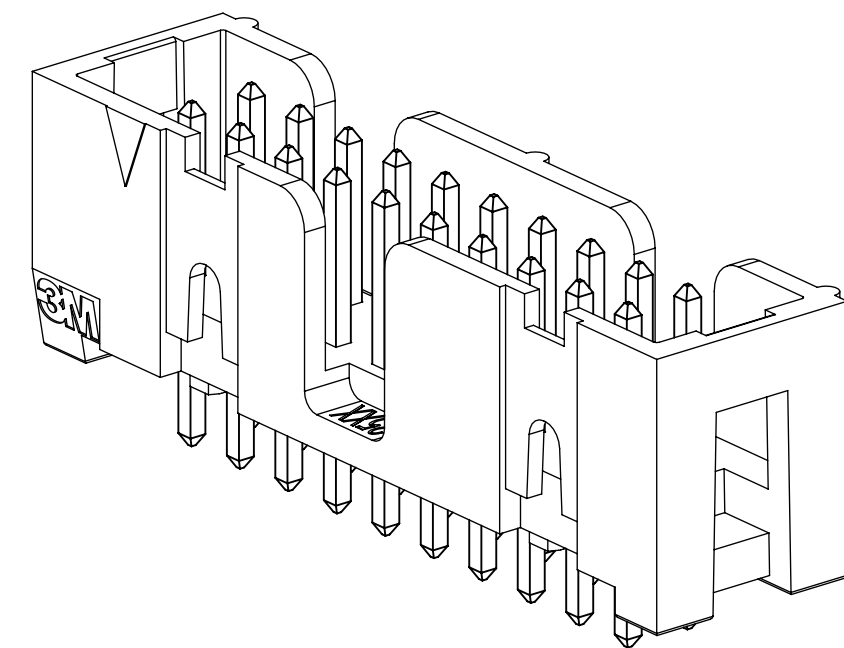

X25XX-60XX
STRAIGHT VERSION

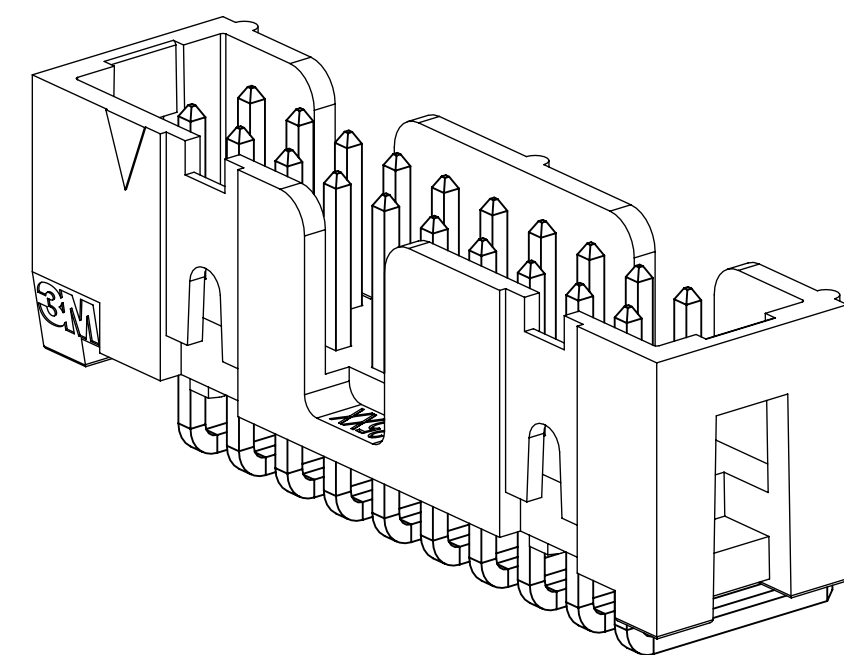

X25XX-50XX
RIGHT ANGLE VERSION

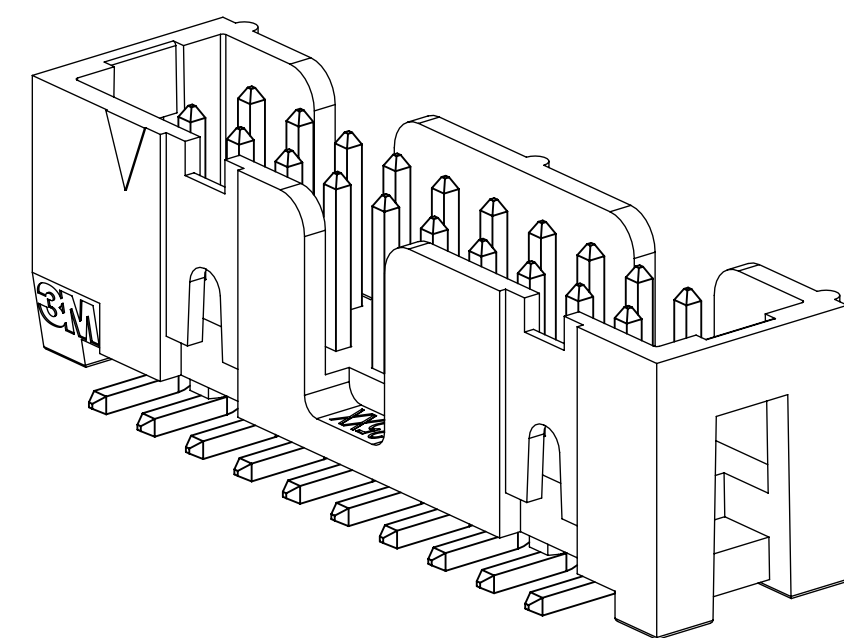

X25XX-6V0C
SURFACE MOUNT VERSION

- * LOW PROFILE, SPACE SAVING DESIGN.
- * CENTER SLOT POLARIZATION PREVENTS MIS-INSERTIONS AND REDUCES INSERTION TIME.
- * DUAL SLOT POLARIZATION MEANS BROADER COMPATIBILITY WITH COMPETITIVE POLARIZATION DESIGNS (NOT AVAILABLE ON 6, 8 OR 10 POSITIONS).
- * OPTIONAL RETAINER CLIP FOR LOCKING SOCKETS IN PLACE AND INCREASING CONNECTION RELIABILITY IN VIBRATION-PRONE ENVIRONMENTS.
- * HIGH TEMPERATURE INSULATOR SUITABLE FOR "NO LEAD" SOLDERING OPERATIONS.
- * THROUGH HOLE VERSION SUITABLE FOR REFLOW SOLDERING USING "PASTE IN HOLE" TECHNIQUES.
- * EXPOSED SOLDER TAILS (ON RIGHT ANGLE VERSION) PROVIDE EASE OF CLEANING AND REDUCED REPAIR COST.
- * STRAIGHT SURFACE MOUNT VERSION AVAILABLE.

2 PHYSICAL :

INSULATOR:
 MATERIAL: HIGH TEMPERATURE GLASS FILLED POLYESTER (PCT)
 FLAMMABILITY: UL94V-0
 COLOR: BLACK
 CONTACT:
 MATERIAL: COPPER ALLOY
 PLATING:
 UNDER PLATING: NICKEL UNDERPLATE (SEE ORDERING INFORMATION)
 WIPING AREA: GOLD (SEE ORDERING INFORMATION)
 SOLDER TAILS: MATTE TIN (SEE ORDERING INFORMATION)
 MARKINGS: 3M LOGO, PART IDENTIFICATION NUMBER AND ORIENTATION TRIANGLE

2 ELECTRICAL :

CURRENT RATING: 5.00A, 1 CONTACT POWERED
 3.00A, 6 CONTACTS POWERED
 1.75A, ALL CONTACTS POWERED
 RATING CONDITIONS: EIA-364-070 METHOD 2, 30°C MAXIMUM TEMPERATURE RISE, 20% DERATED. REFERENCE APPROPRIATE 3M PRODUCT SPECIFICATION FOR DETAILED CURRENT DERATING CURVES.
 INSULATION RESISTANCE: >1 X 10⁹Ω AT 500 V_{DC}
 WITHSTANDING VOLTAGE: 1,000V_{RMS} AT SEA LEVEL

2 ENVIRONMENTAL :

TEMPERATURE RATING: -55°C TO 105°C
 PROCESS RATING: 260°C, PER J-STD-020C, SINGLE PASS
 MOISTURE SENSITIVITY LEVEL: 1 (PER J-STD-020C)

- NOTES
1. REGULATORY INFORMATION: VISIT 3M.com/regs
 2. IN THE EVENT OF CONFLICT BETWEEN THIS DATA AND THAT CONTAINED IN THE PRODUCT SPECIFICATION, THE PRODUCT SPECIFICATION TAKES PRECEDENT.
 3. NOTCHES A & C WILL ACCOMODATE 3M POLARIZING KEY: N3518.
 4. CONTACT TAILS .0245 [.622] WIRE WITH .0075 [.191] CORNER RADIUS AND .028 [.072] DIAGONAL.
 5. SOLDER STANDOFFS FACILITATE .01 [.3] CLEARANCE ABOVE BOARD FOR REFLOW SOLDERING.

DIMENSIONS: INCHES [MM]

DESIGN REFERENCE	NEXT ASSEMBLY	REV	ECO	ISSUE DATE AND DESCRIPTION	DRFT	CHKD
DRWG CODES		DRFT	ECO	DATE	MFG	DATE
		CASTIGLIONE		AUG 11, 2014		
		CHKD		DATE	APPV	DATE
					R. SCHERER	SEP 05, 2014
DIVISION	DIVISION CODE	© 3M COPYR [GHT] 2020 This document and the information it contains are 3M property and may not be reproduced or further distributed without 3M permission, or used or disclosed other than for 3M authorized purposes. All rights reserved.				
Interconnect Solutions	EMSD	3M Center St. Paul, MN 55144				
DO NOT SCALE DRAWING	SCALE 4/1	TOLERANCES EXCEPT AS NOTED INCHES: .0 ± .1 .00 ± .01 .000 ± .005 .0000 ± .0002 MILLIMETERS: 0 ± 2 INTERPRET PER ASME Y14.5 - 2018 .0 ± .3 .00 ± .13 .000 ± .005 MAX SURFACE ROUGHNESS: SURFACES SURFACES MARKED ONLY				
THIRD ANGLE PROJECTION		TITLE HEADER, 4-WALL, LO-PRO, .100 X .100, SMT, STRAIGHT & RA				
		CAGE NUMBER	SIZE	DRAWING NO.	REV.	
		D		78-5100-0770-7	P	
		MODEL		2500 SERIES	DET	ISTS
					YES	NO
					SHT	1 OF 6

3M ELECTRONIC MATERIALS SOLUTIONS DIVISION
 INTERCONNECT SOLUTIONS
<http://www.3mconnectors.com>

3M IS A TRADEMARK OF 3M COMPANY.
 FOR TECHNICAL, SALES OR ORDERING INFORMATION CALL 800-225-5373

CAUS
 UL FILE NO: E68080

P REVISION
 78-5100-0770-7
 DRAWING NUMBER
 B
 UTC
 Off-set (hrs)
 6
 Time 9/14/2020

3M™ FOUR-WALL HEADER, 2500 SERIES
 .100" X .100" LOW PROFILE, SURFACE MOUNT, STRAIGHT AND RIGHT ANGLE THROUGH-HOLE

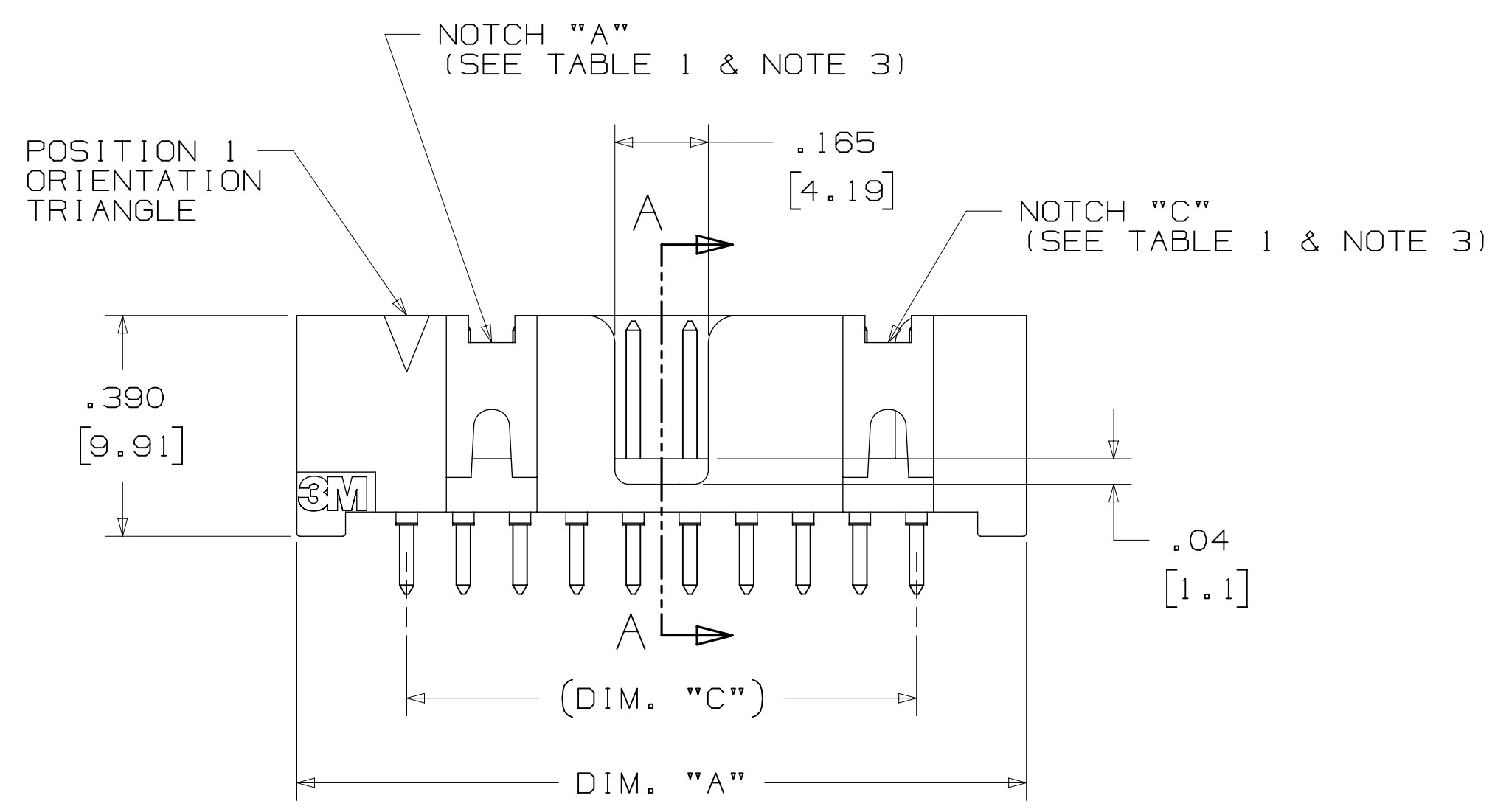
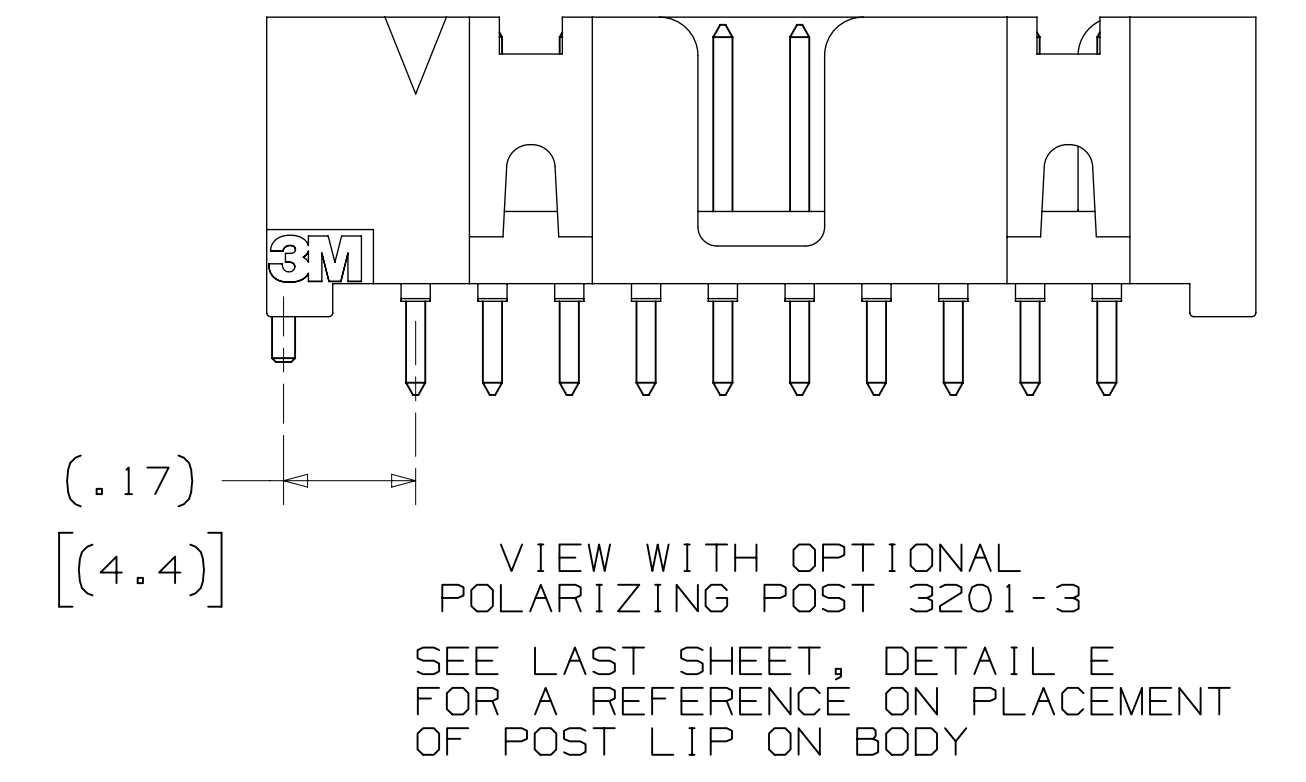
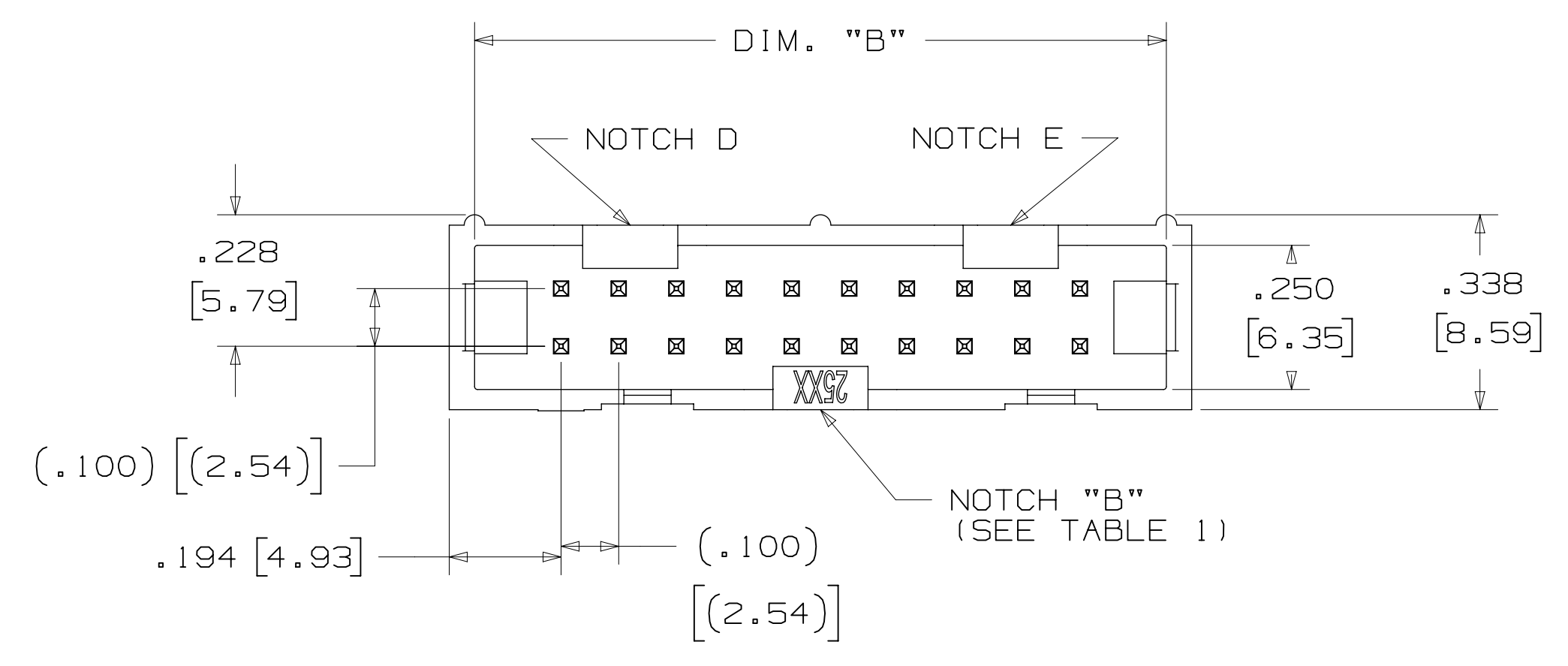
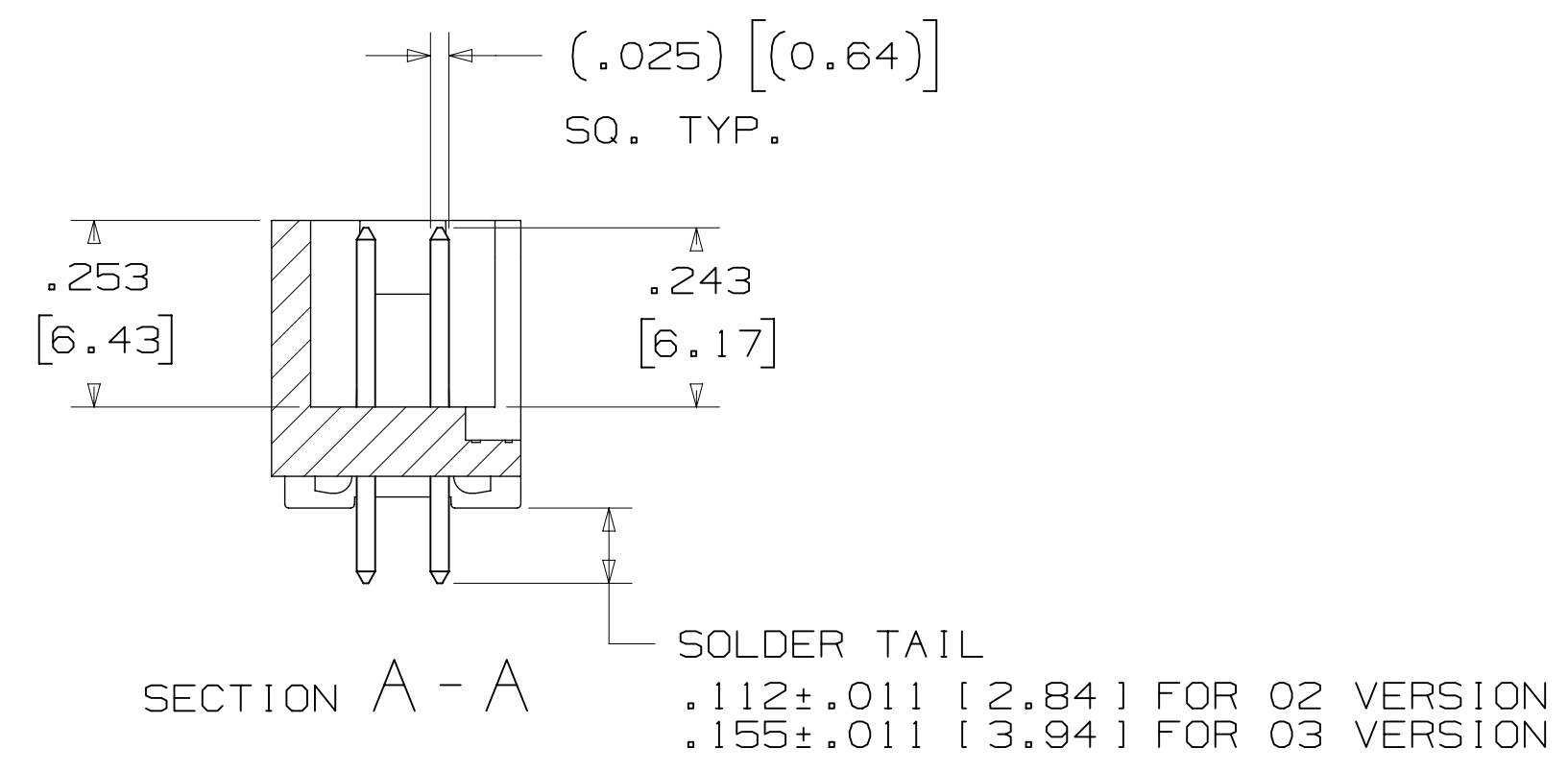

PIN QTY.	DIM. "A"	DIM. "B"	DIM. "C"	POLARIZING NOTCHES	PIN QTY.
06	.588 [14.94]	.508 [12.90]	.200 [5.08]	B	06
08	.688 [17.48]	.608 [15.44]	.300 [7.62]	B	08
10	.788 [20.02]	.708 [17.98]	.400 [10.16]	BC	10
14	.988 [25.10]	.908 [23.06]	.600 [15.24]	BCDE	14
16	1.088 [27.64]	1.008 [25.60]	.700 [17.78]	ABCDE	16
20	1.288 [32.72]	1.208 [30.68]	.900 [22.86]	ABCDE	20
24	1.488 [37.80]	1.408 [35.76]	1.100 [27.94]	ABCDE	24
26	1.588 [40.34]	1.508 [38.30]	1.200 [30.48]	ABCDE	26
30	1.788 [45.42]	1.708 [43.38]	1.400 [35.56]	ABCDE	30
34	1.988 [50.50]	1.908 [48.46]	1.600 [40.64]	ABCDE	34
36	2.088 [53.04]	2.008 [51.00]	1.700 [43.18]	ABCDE	36
40	2.288 [58.12]	2.208 [56.08]	1.900 [48.26]	ABCDE	40
50	2.788 [70.82]	2.708 [68.78]	2.400 [60.96]	ABCDE	50
60	3.288 [83.52]	3.208 [81.48]	2.900 [73.66]	ABCDE	60
64	3.488 [88.60]	3.408 [86.56]	3.100 [78.74]	ABCDE	64

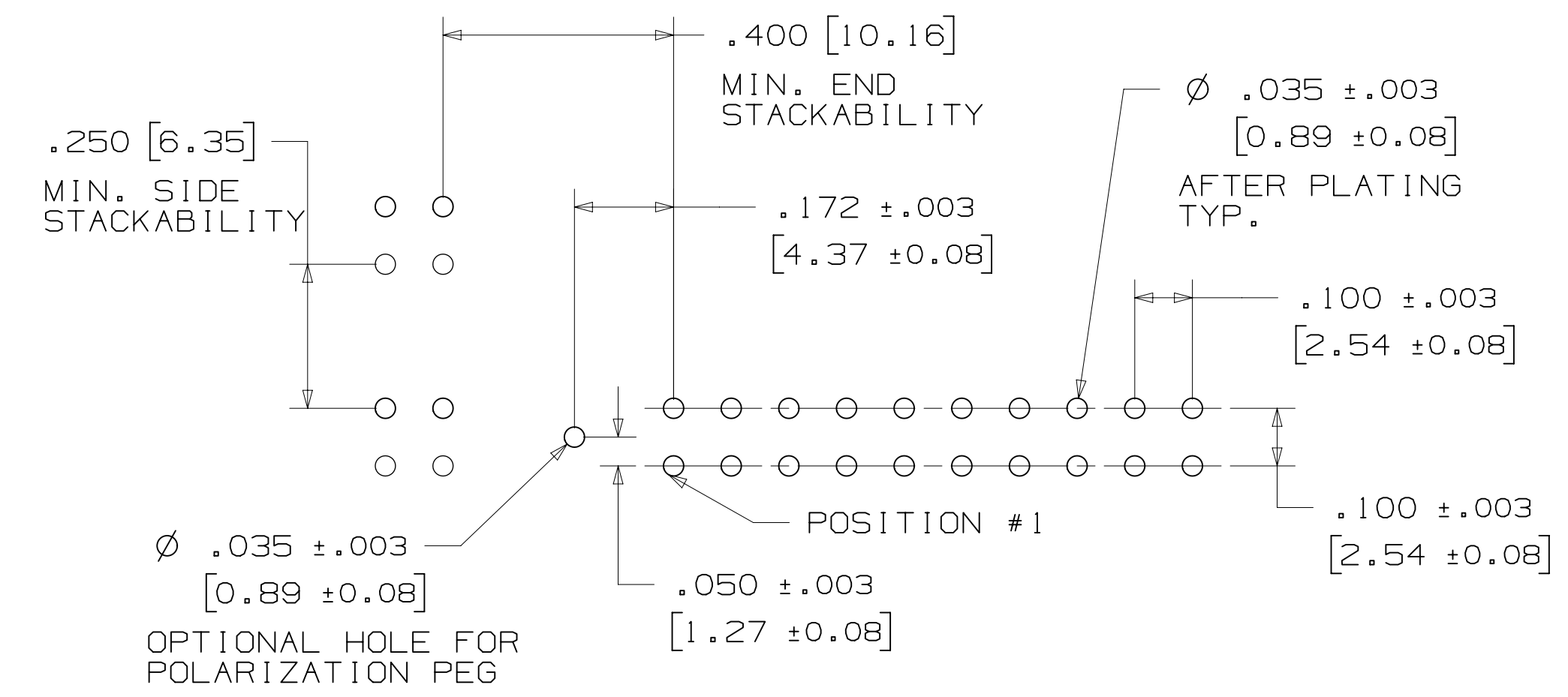

ORDERING INFORMATION
 STRAIGHT VERSION

X25XX-60XX-XX

N = RB PLATING REQ'D
 D = AR PLATING REQ'D (O2 SOLDER TAIL ONLY)

PIN QUANTITY: (SEE TABLE 1)

SOLDER TAIL:
 O2 = FOR .062 [1.57] THICK BOARD
 O3 = FOR .094 TO .125 [2.39 TO 3.18] THICK BOARD (SOLDER TAIL LENGTH ONLY AVAILABLE ON N25XX-60XX-RB)

PLATING:
 AR = 10μ" [0.25μm] GOLD AVG.
 50μ-150μ [1.27μm-3.81μm] NICKEL UNDERPLATE
 40μ-120μ [1.02μm-3.05μm] MATTE TIN (RIA, E1 & C1 APPLY)

RB = 30μ" [0.76μm] GOLD AVG.
 50μ-150μ [1.27μm-3.81μm] NICKEL UNDERPLATE
 25μ-200μ [0.63μm-5.08μm] MATTE TIN (RIA, E1 & C1 APPLY)

RECOMMENDED HOLE PATTERN
 SHOWN FROM COMPONENT SIDE

DESIGN REFERENCE	NEXT ASSEMBLY	REV	ECO	ISSUE DATE AND DESCRIPTION	DRFT	CHKD
DIVISION CODES		DIVISION CODE		DATE		
Interconnect Solutions		EMSD		AUG 11, 2014		
DO NOT SCALE DRAWING	SCALE 4-1	TOLERANCES EXCEPT AS NOTED		DATE		
		INCHES		DATE		
		.00 ±.01		SEP 05, 2014		
		.000 ±.005				
		.0000 ±.0002				
THIRD ANGLE PROJECTION		MILLIMETERS				
INTERPRET PER ASME Y14.5 - 2018		0 ±2				
MAX SURFACE ROUGHNESS		.00 ±.13				
UNFINISHED SURFACES		.000 ±.005				
MARKED ONLY		ANGLES				
		CAGE NUMBER		DRAWING NO.		
		D 78-5100-0770-7		P		
		MODEL		2500 SERIES		
		DET		Ists		
		YES		NO		
		SHT 2		OF 6		

© 3M COPYR [GHT] 2020
 This document and the information it contains are 3M property and may not be reproduced or further distributed without 3M permission, or used or disclosed other than for 3M authorized purposes. All rights reserved.

3M Center St. Paul, MN 55144

REVISIONS:

REV	ECO	ISSUE DATE AND DESCRIPTION	DRFT	CHKD
P	89702	JUL 08, 2020 REVISE DRAWING PER NEW HEADER MODEL	JNC	SN
N	68908	AUG 02, 2016 REVISE DIM ON SHT2 & CLIP CHART ON SHT5	JNC	SC
M	56068	AUG 11, 2014 REVISED AND REDRAWN	JNC	RS

78-5100-0770-7
 6
 5
 4
 3
 2
 1
 UTC
 hrs
 set
 Drf

3M™ FOUR-WALL HEADER, 2500 SERIES

.100" X .100" LOW PROFILE, SURFACE MOUNT, STRAIGHT AND RIGHT ANGLE THROUGH-HOLE

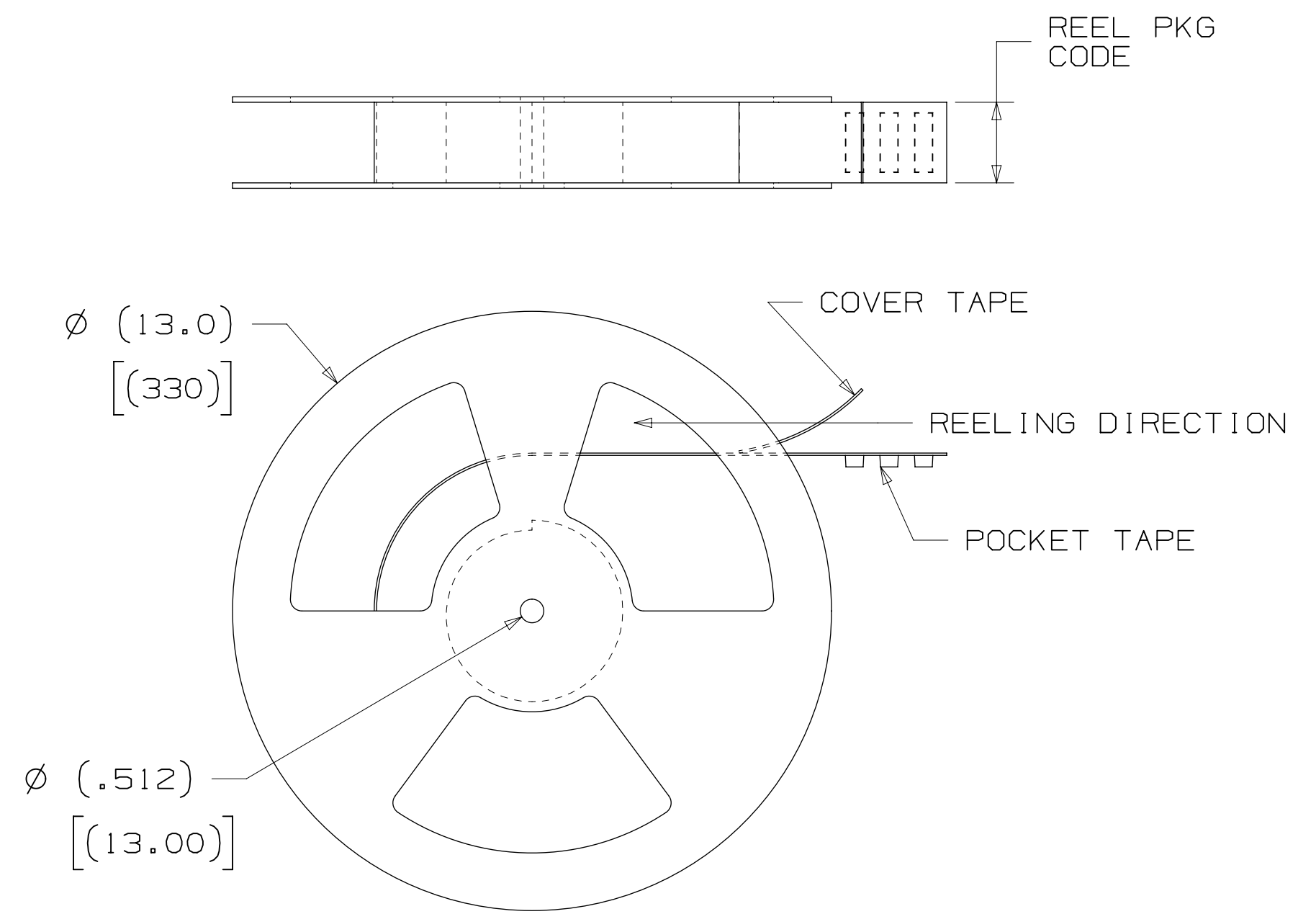
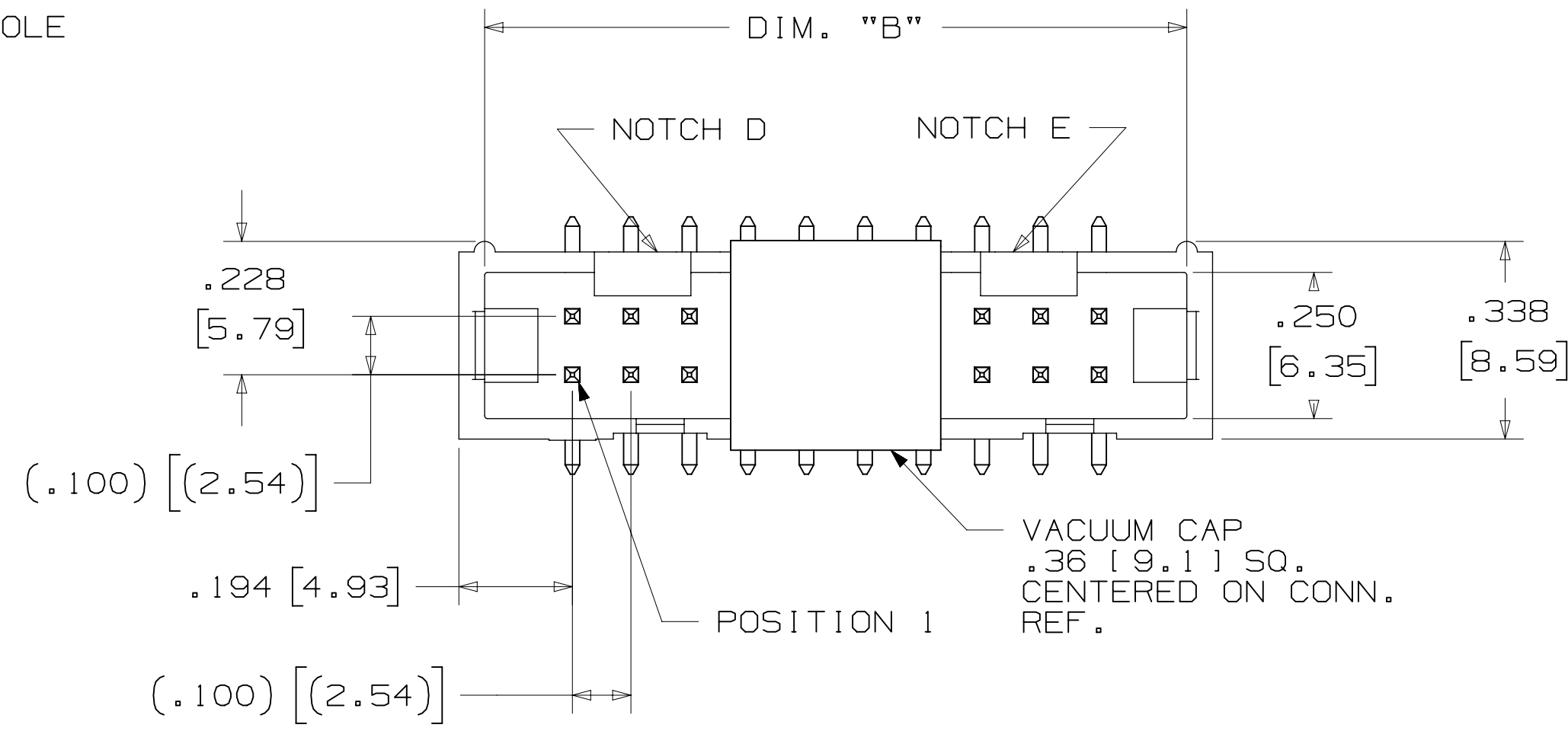
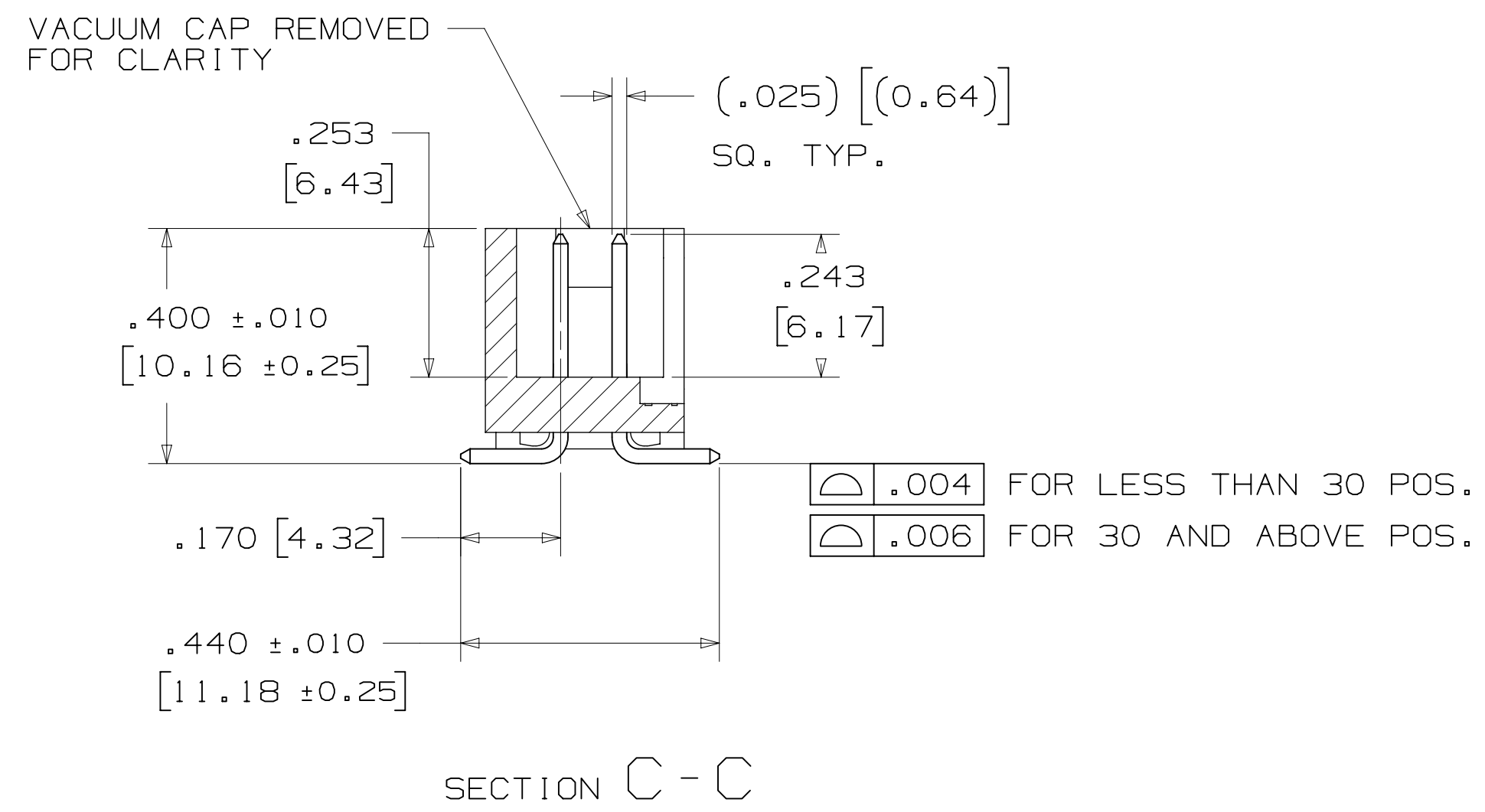
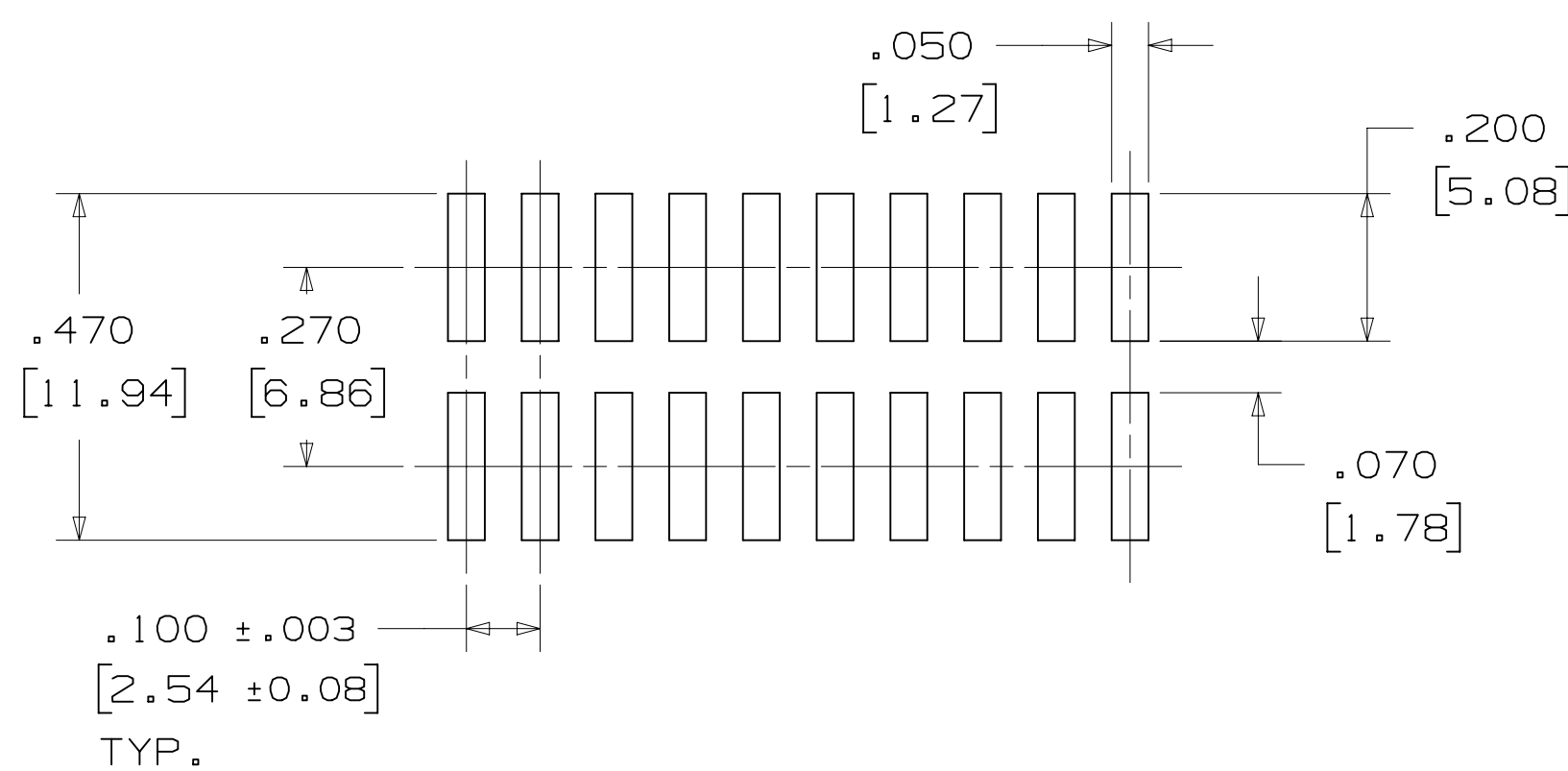
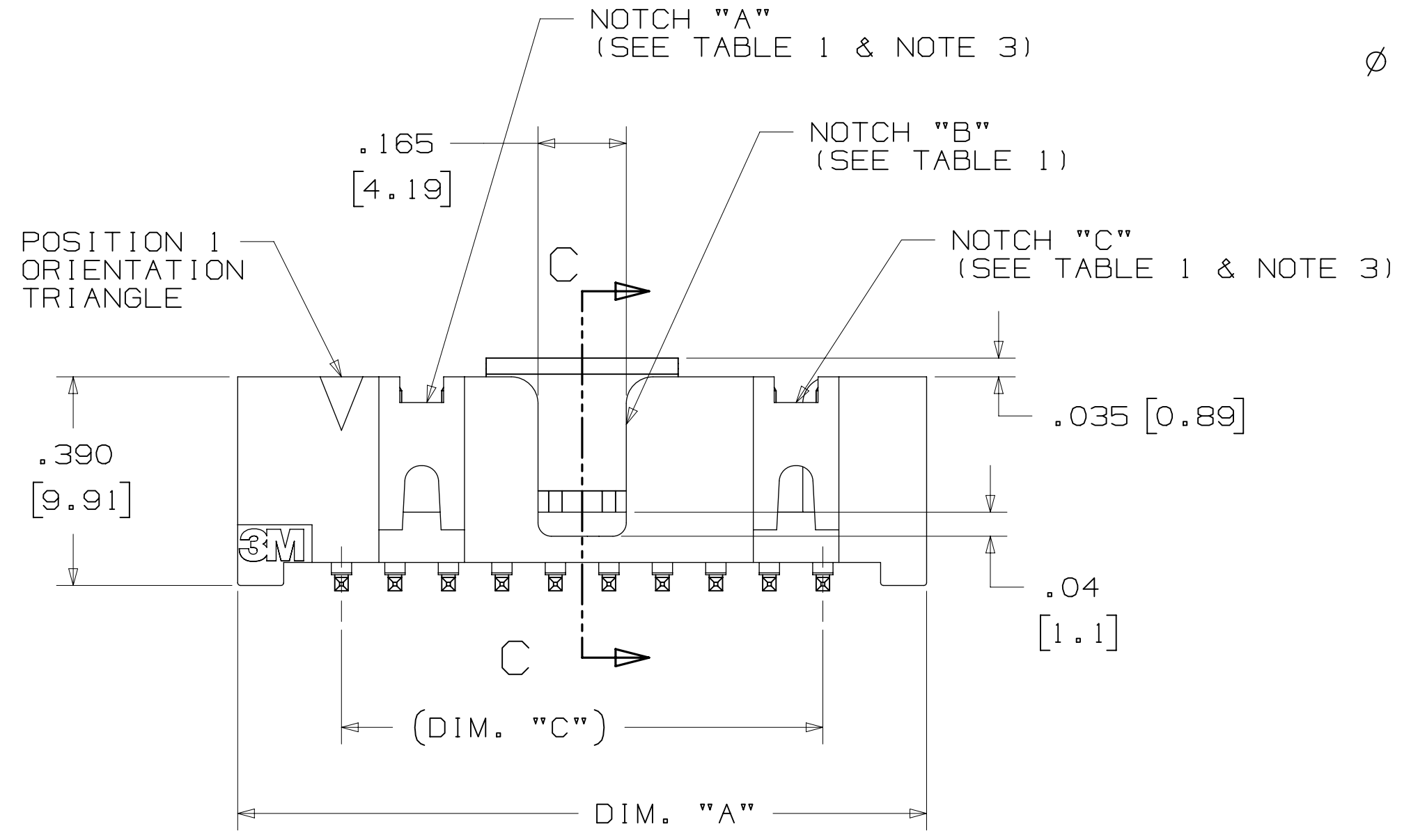

TABLE 1						
PIN QTY.	DIM. "A"	DIM. "B"	DIM. "C"	POLARIZING NOTCHES	TAPE AND REEL PKG CODE	PIN QTY.
06	.588 [14.94]	.508 [12.90]	.200 [5.08]	B	WD (44 MM)	06
08	.688 [17.48]	.608 [15.44]	.300 [7.62]	B	WD (44 MM)	08
10	.788 [20.02]	.708 [17.98]	.400 [10.16]	BC	WD (44 MM)	10
14	.988 [25.10]	.908 [23.06]	.600 [15.24]	BCDE	WD (44 MM)	14
16	1.088 [27.64]	1.008 [25.60]	.700 [17.78]	ABCDE	WD (44 MM)	16
20	1.288 [32.72]	1.208 [30.68]	.900 [22.86]	ABCDE	WE (56 MM)	20
24	1.488 [37.80]	1.408 [35.76]	1.100 [27.94]	ABCDE	WE (56 MM)	24
26	1.588 [40.34]	1.508 [38.30]	1.200 [30.48]	ABCDE	WE (56 MM)	26
30	1.788 [45.42]	1.708 [43.38]	1.400 [35.56]	ABCDE	WF (72 MM)	30
34	1.988 [50.50]	1.908 [48.46]	1.600 [40.64]	ABCDE	WF (72 MM)	34
36	2.088 [53.04]	2.008 [51.00]	1.700 [43.18]	ABCDE	WG (88 MM)	36
40	2.288 [58.12]	2.208 [56.08]	1.900 [48.26]	ABCDE	WG (88 MM)	40
50	2.788 [70.82]	2.708 [68.78]	2.400 [60.96]	ABCDE	WG (88 MM)	50
60	3.288 [83.52]	3.208 [81.48]	2.900 [73.66]	ABCDE	WH (120 MM)	60
64	3.488 [88.60]	3.408 [86.56]	3.100 [78.74]	ABCDE	WH (120 MM)	64



ORDERING INFORMATION SURFACE MOUNT VERSION

X25XX-6VOC-XX-XX

N = RB PLATING REQ'D
D = AR PLATING REQ'D

PIN QUANTITY:
(SEE TABLE 1)

PACKAGING OPTIONS:
WX = TAPE & REEL PACKAGING (SEE TABLE 1)

PLATING:
AR = 10µ" [0.25µm] GOLD AVG.
50µ-150µ [1.27µm-3.81µm] NICKEL UNDERPLATE
40µ-120µ" [1.02µm-3.05µm] MATTE TIN (RIA, E1 & C1 APPLY)
RB = 30µ" [0.76µm] GOLD AVG.
50µ-150µ [1.27µm-3.81µm] NICKEL UNDERPLATE
25µ-200µ" [0.63µm-5.08µm] MATTE TIN (RIA, E1 & C1 APPLY)

RECOMMENDED PAD LAYOUT

DESIGN REFERENCE	NEXT ASSEMBLY	REV	ECO	ISSUE DATE AND DESCRIPTION	DRFT	CHKD
				AUG 11, 2014		
DIVISION: Interconnect Solutions		DIVISION CODE: EMSD		DATE: SEP 05, 2014		
DO NOT SCALE DRAWING	SCALE: 4-1	TOLERANCES EXCEPT AS NOTED		DATE: AUG 11, 2014		
THIRD ANGLE PROJECTION	INTERPRET PER ASME Y14.5 - 2018	MILLIMETERS		DATE: SEP 05, 2014		
MAX SURFACE ROUGHNESS	MARKED ONLY	INCHES		DATE: SEP 05, 2014		
		.00 ± .01		DATE: SEP 05, 2014		
		.000 ± .005		DATE: SEP 05, 2014		
		.0000 ± .0002		DATE: SEP 05, 2014		
		.0 ± .2		DATE: SEP 05, 2014		
		.00 ± .13		DATE: SEP 05, 2014		
		.000 ± .005		DATE: SEP 05, 2014		
		ANGLES		DATE: SEP 05, 2014		

P	89702	JUL 08, 2020	JNC	SN
N	68908	AUG 02, 2016	JNC	SC
M	56068	AUG 11, 2014	JNC	RS

3M Center St. Paul, MN 55144

© 3M COPYR [GHT] 2020
This document and the information it contains are 3M property and may not be reproduced or further distributed without 3M permission, or used or disclosed other than for 3M authorized purposes. All rights reserved.

TITLE: HEADER, 4-WALL, LO-PRO, .100 X .100, SMT, STRAIGHT & RA

CAGE NUMBER: D78-5100-0770-7

MODEL: 2500 SERIES

REV. P

DET: [] SHT 4 OF 6

Imaged: Central Standard Time 9/14/2020 -- UTC Drf-set (hrs) 6

3M™ FOUR-WALL HEADER, 2500 SERIES
 .100" X .100" LOW PROFILE, SURFACE MOUNT, STRAIGHT AND RIGHT ANGLE THROUGH-HOLE

PART CUSTOMIZATION

THIS SPEC SHEET DETAILS OUR STANDARD OFFERING.
 3M HAS SEVERAL CAPABILITIES THAT CAN PROVIDE A PART TAILORED TO YOUR SPECIFIC NEEDS. ASK YOUR 3M SALES REPRESENTATIVE OR CUSTOMER SERVICE FOR MORE DETAILS.
 * SELECTIVE PIN REMOVAL (FOR BOARD ASSEMBLY POLARIZATION).
 * DIFFERENT PIN LENGTHS.

POLARIZING KEY

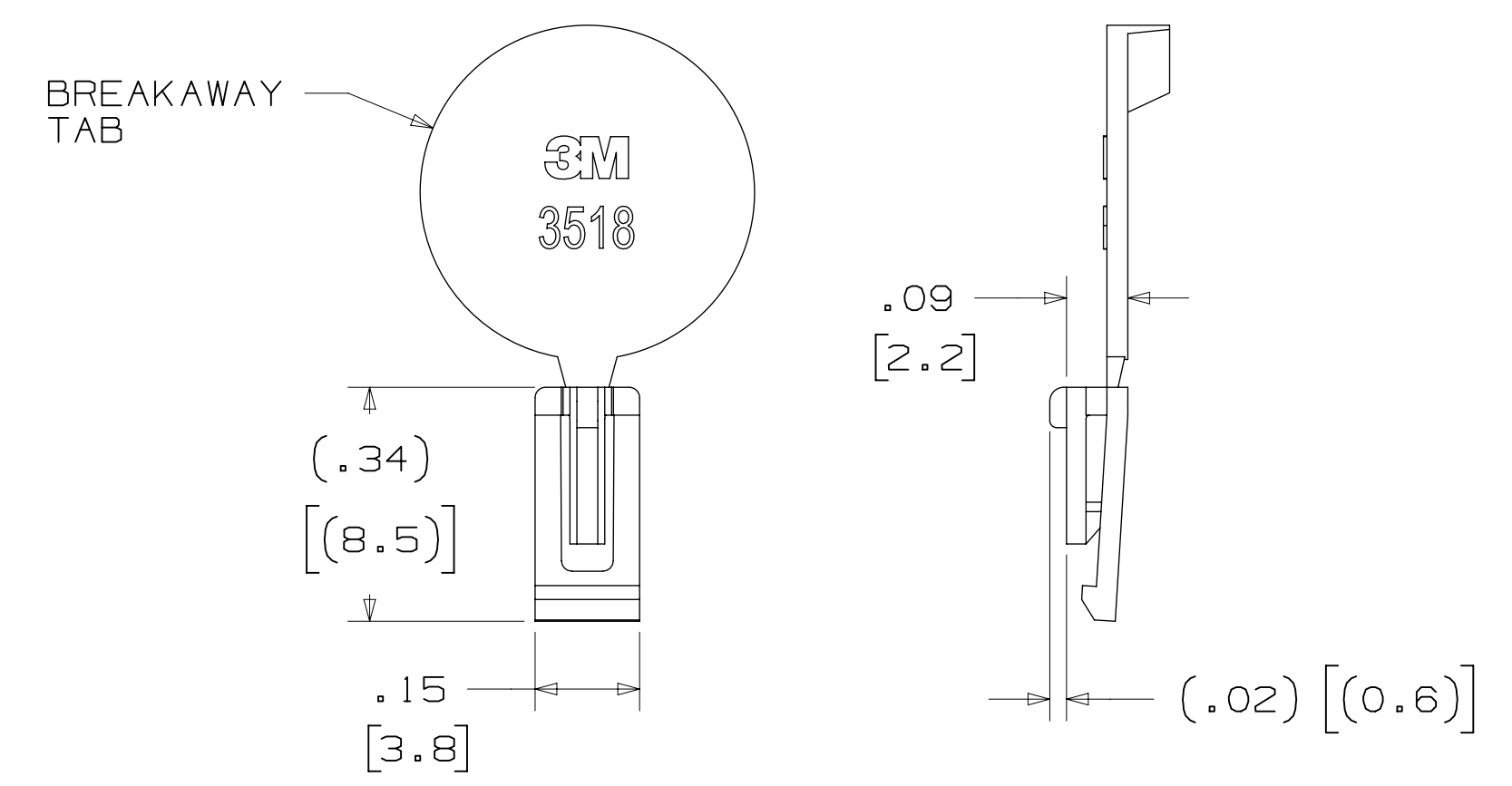

3M PART NO.	MATERIAL	COLOR
3518	PBT	GRAY
N3518	LCP	BLACK
D3518	PBT	BLACK

NOTE:
 1) #2216 B/A SCOTCHWELD CAN BE USED TO ADHERE KEYS.
 2) SEE INSTRUCTION SHEET 78-9100-7795-3 FOR ASSEMBLY.

LOW PROFILE LATCH

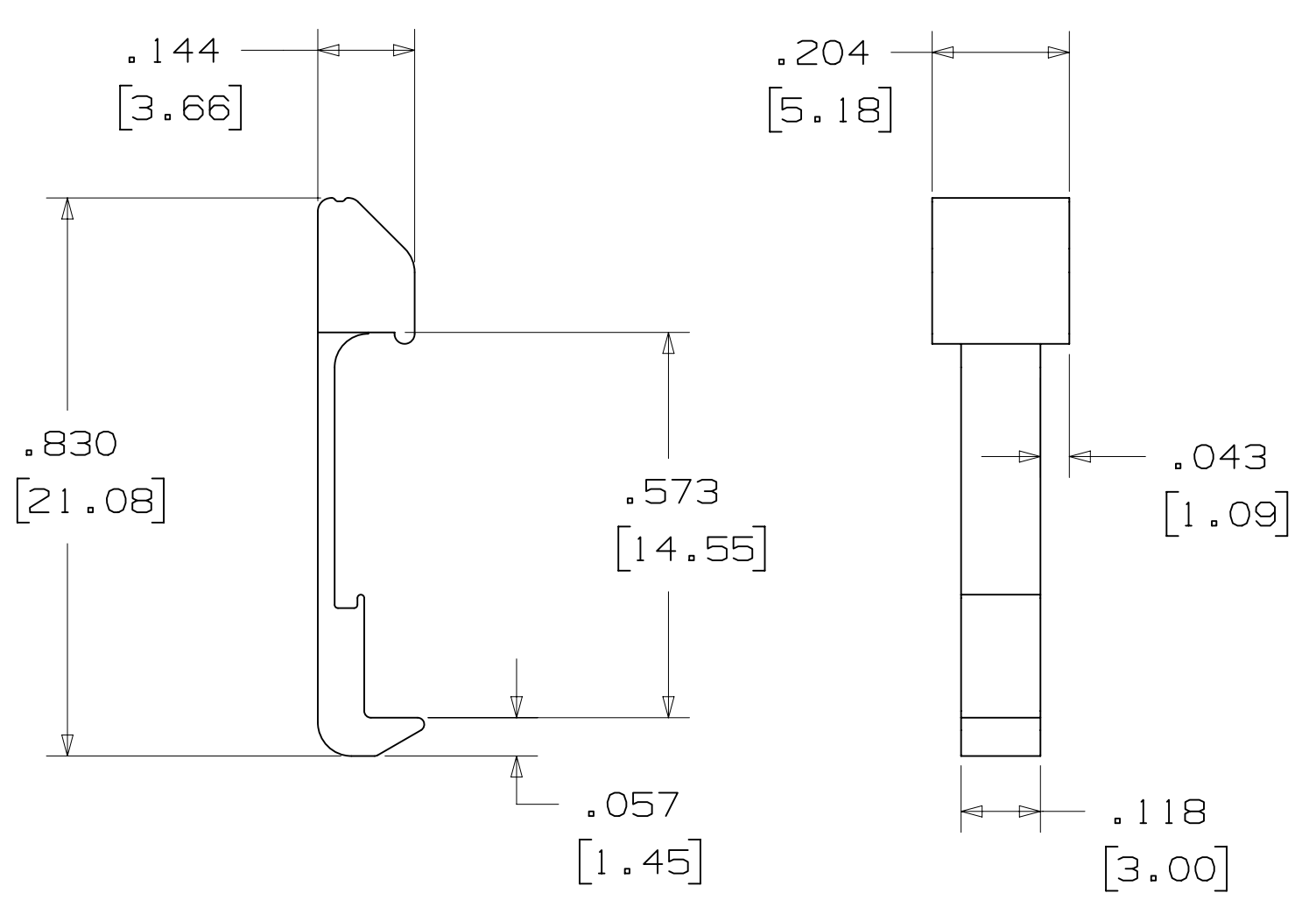

PART NO.	MATERIAL	COLOR
3505-33B	NYLON	BLACK

NOTE:
 1. LATCHES NOT COMPATIBLE WITH REFLOW SOLDERING. ATTACH LATCHES AFTER SOLDERING.
 2. LATCHES ARE MEANT FOR RETENTION ONLY.
 3. SEE LAST SHEET FOR ASSEMBLY.

POLARIZING POST

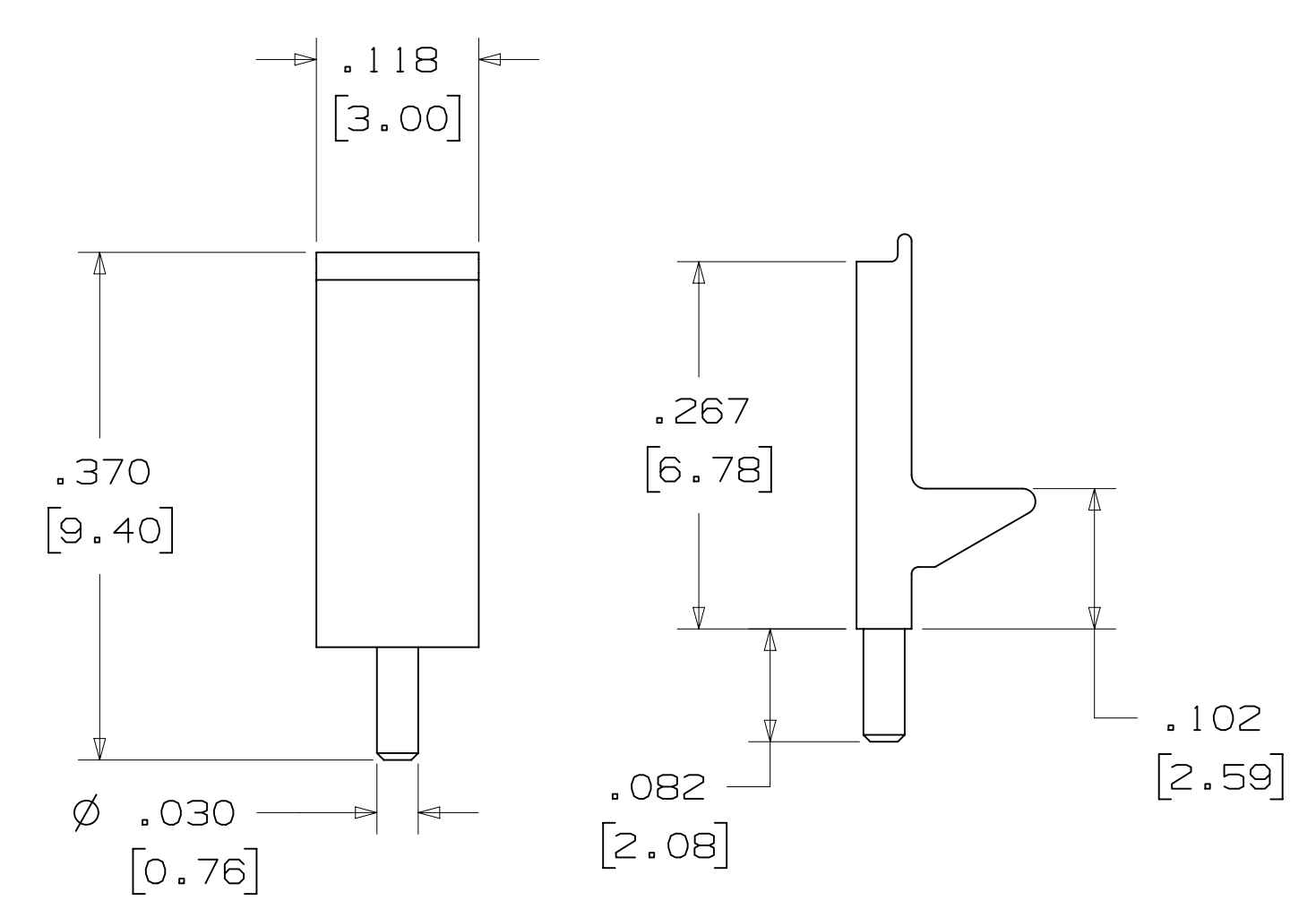

PART NO.	MATERIAL	COLOR
3201-3	PCT	BLACK

SHORT/LONG SOCKET RETAINER CLIP

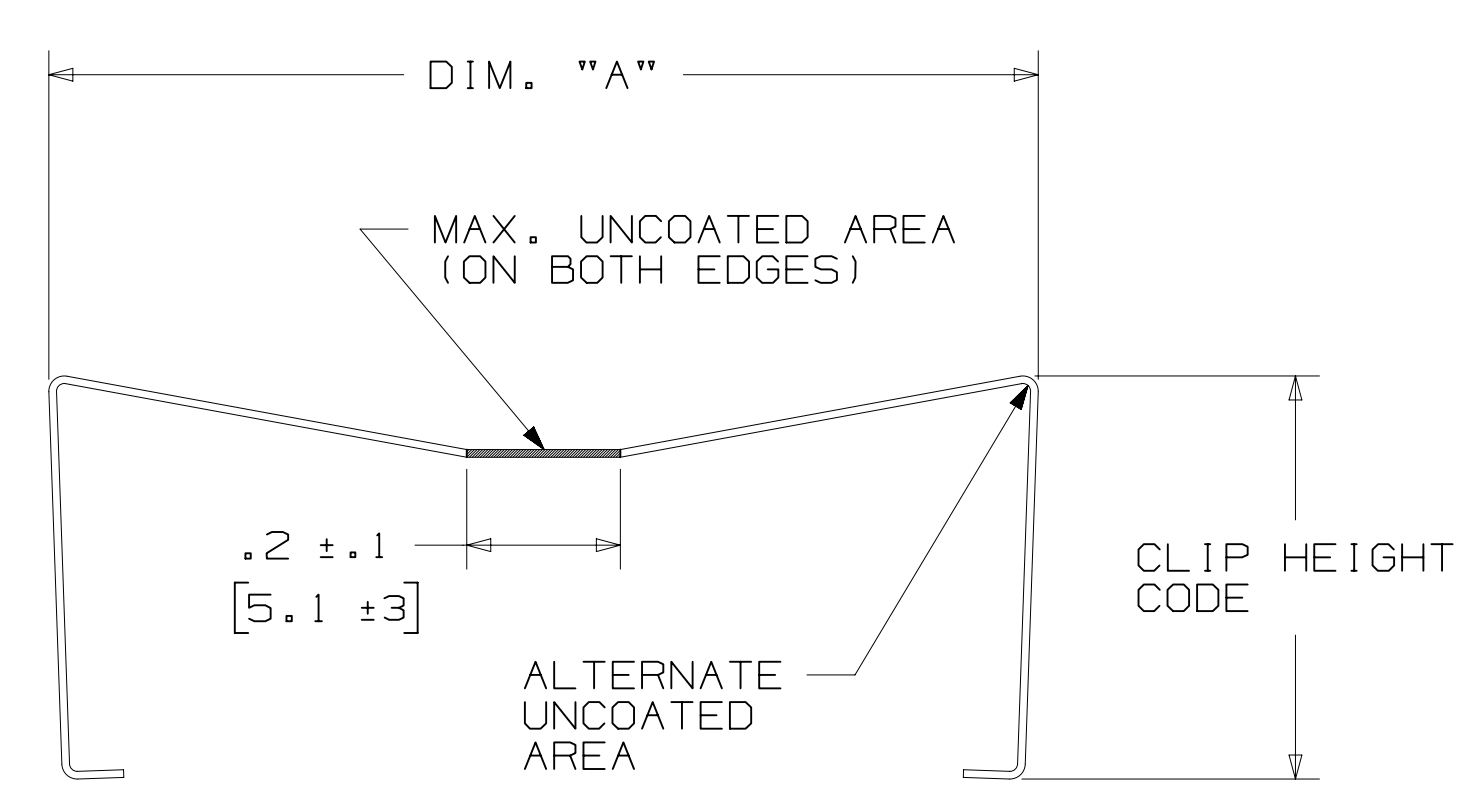

PIN QTY.	DIM. "A"
06	N/A
08	N/A
10	.81 [20.6]
14	1.02 [25.9]
16	1.12 [28.4]
20	1.32 [33.5]
24	1.52 [38.7]
26	1.63 [41.4]
30	1.83 [46.4]
34	2.03 [51.6]
36	N/A
40	2.33 [59.2]
50	2.83 [71.9]
60	3.33 [84.6]
64	3.53 [89.7]

NOTE:
 STAINLESS STEEL WITH GRAY POLYURETHANE COATING.

3505-8XXX

CLIP HEIGHT CODE _____ PIN COUNT (SEE TABLE)
 0 = .31 [7.9] FOR SOCKETS WITHOUT STRAIN RELIEF
 1 = .53 [13.5] FOR SOCKETS WITH STRAIN RELIEF

NOTE:
 1) THE FOLLOWING RETAINER CLIPS HAVE BEEN DISCONTINUED:
 3505-8064
 3505-8124
 3505-8150

DESIGN REFERENCE	NEXT ASSEMBLY	REV	ECO	ISSUE DATE AND DESCRIPTION	DRFT	CHKD
ACROSS CODES		CASTIGLIONE	AUG 11, 2014	MFG DATE		
DIVISION	DIVISION CODE	APPR	DATE	DATE		
Interconnect Solutions	EMSD	R. SCHERER	SEP 05, 2014			
DO NOT SCALE DRAWING	SCALE 4/1	TOLERANCES EXCEPT AS NOTED		© 3M COPYR [GHT] 2020 This document and the information it contains are 3M property and may not be reproduced or further distributed without 3M permission, or used or disclosed other than for 3M authorized purposes. All rights reserved.		
THIRD ANGLE PROJECTION	INTERPRET PER ASME Y14.5 - 2018	INCHES .00 ± .01 .000 ± .005 .0000 ± .0002		TITLE HEADER, 4-WALL, LO-PRO, .100 X .100, SMT, STRAIGHT & RA		
MAX SURFACE ROUGHNESS	MARKED ONLY	MILLIMETERS 0 ± .2 .00 ± .13 .000 ± .005		CAGE NUMBER D78-5100-0770-7		
		ANGLE ±		MODEL 2500 SERIES		

P REVISION
 78-5100-0770-7
 DRAWING NUMBER
 B
 6
 Drr-set (hrs)
 9/14/2020
 Time
 -- UTC
 6
 A

3M™ FOUR-WALL HEADER, 2500 SERIES

.100" X .100" LOW PROFILE, SURFACE MOUNT, STRAIGHT AND RIGHT ANGLE THROUGH-HOLE

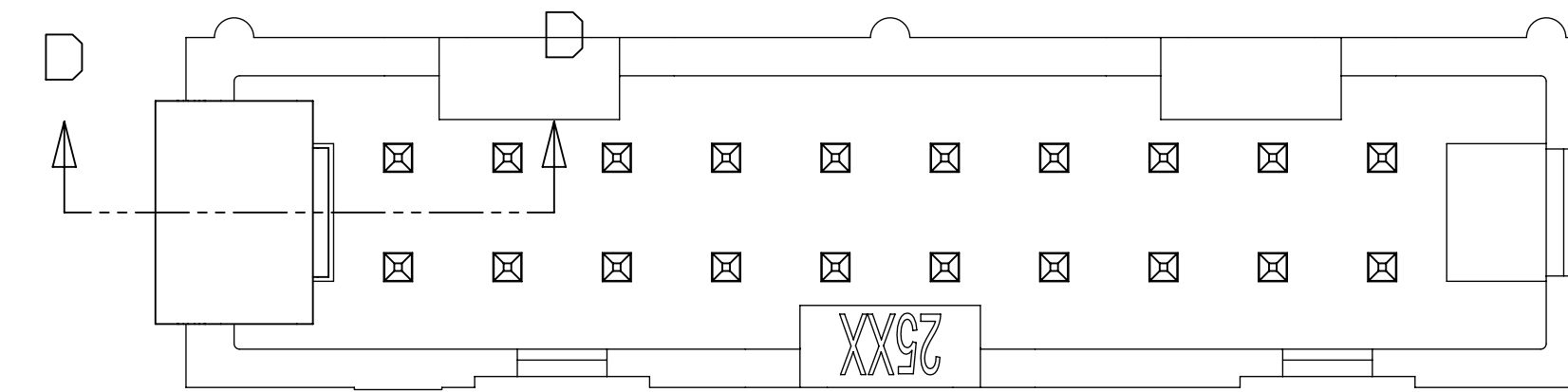

Regulatory: For regulatory information about this product, visit 3M.com/regs or contact your 3M representative.

Technical Information: The technical information, recommendations and other statements contained in this document are based upon tests or experience that 3M believes are reliable, but the accuracy or completeness of such information is not guaranteed.

Product Use: Many factors beyond 3M's control and uniquely within user's control can affect the use and performance of a 3M product in a particular application. Given the variety of factors that can affect the use and performance of a 3M product, user is solely responsible for evaluating the 3M product and determining whether it is fit for a particular purpose and suitable for user's method of application.

Warranty, Limited Remedy, and Disclaimer: Unless an additional warranty is specifically stated on the applicable 3M product packaging or product literature, 3M warrants that each 3M product meets the applicable 3M product specification at the time 3M ships the product. 3M MAKES NO OTHER WARRANTIES OR CONDITIONS, EXPRESS OR IMPLIED, INCLUDING, BUT NOT LIMITED TO, ANY IMPLIED WARRANTY OR CONDITION OF MERCHANTABILITY OR FITNESS FOR A PARTICULAR PURPOSE OR ANY IMPLIED WARRANTY OR CONDITION ARISING OUT OF A COURSE OF DEALING, CUSTOM OR USAGE OR TRADE. If the 3M product does not conform to this warranty, then the sole and exclusive remedy is, at 3M's option, replacement of the 3M product or refund of the purchase price.

Limitation of Liability: Except where prohibited by law, 3M will not be liable for any loss or damage arising from the 3M product, whether direct, indirect, special, incidental or consequential, regardless of the legal theory asserted, including warranty, contract, negligence or strict liability.

3M Company
 Electronics Materials Solutions Division
 13011 McCallen Pass, Bldg. C
 Austin, TX 78753-5380
 1-800-225-5373
www.3M.com/interconnect

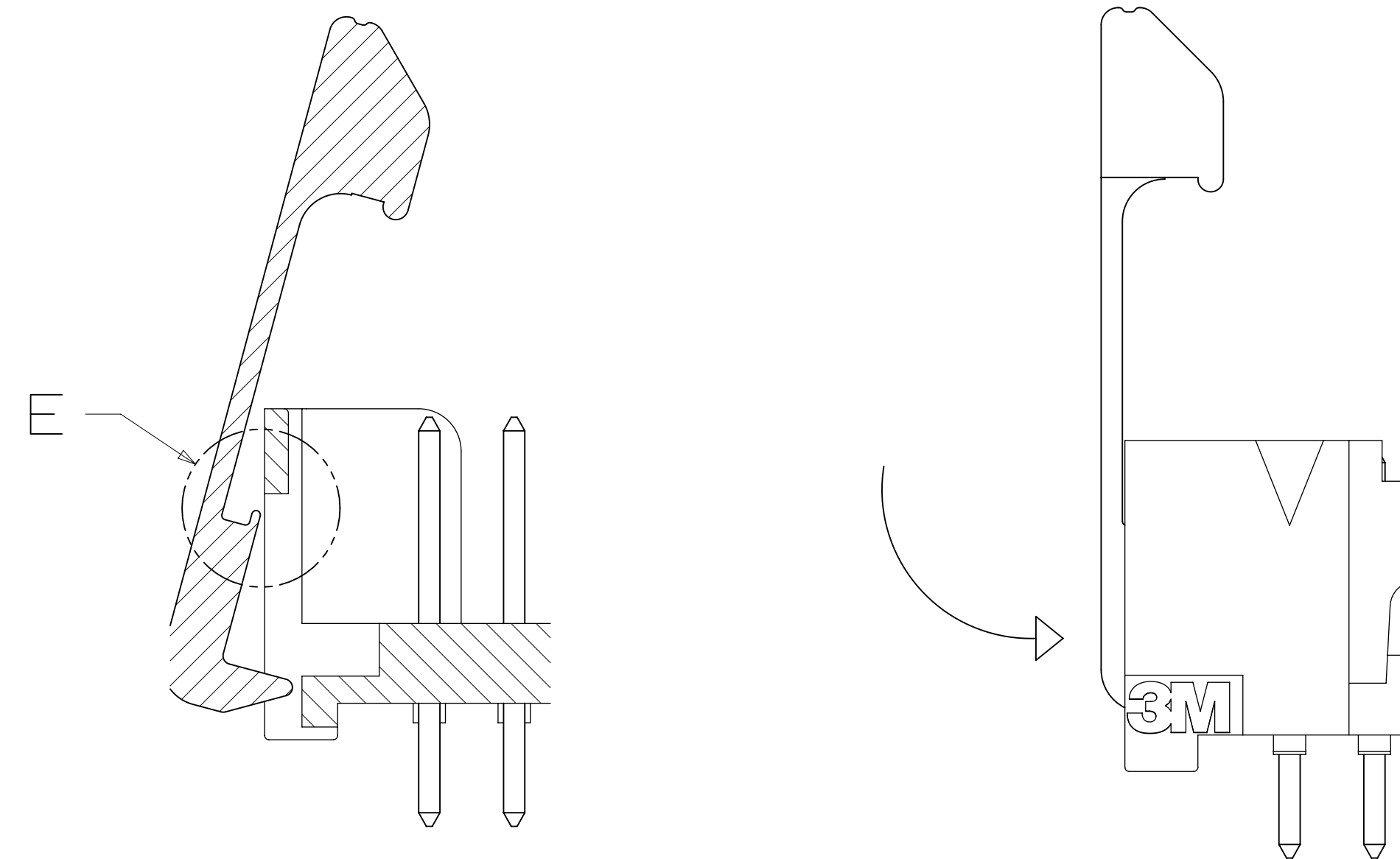

SECTION D-D
 SCALE 6x

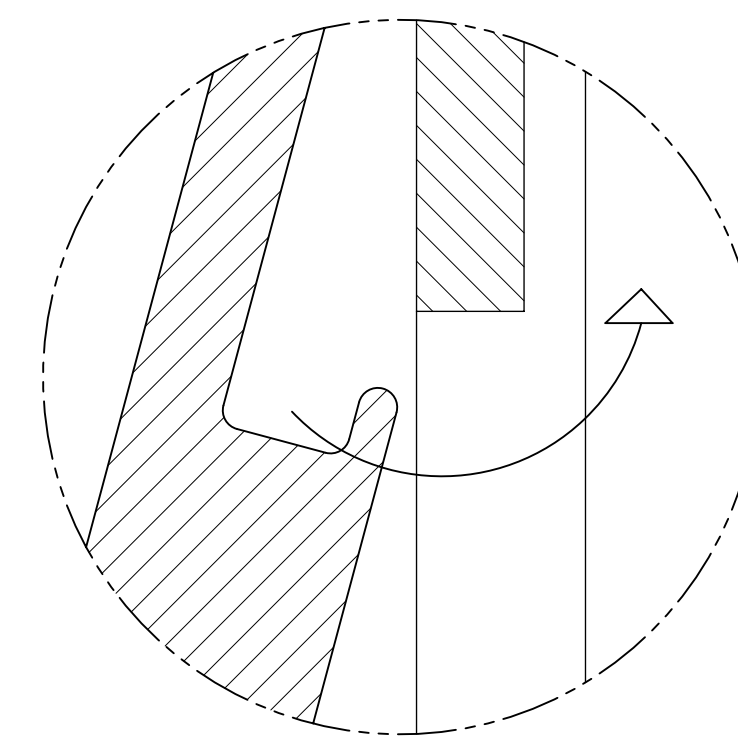

Detail E
 SCALE 20x

TO ASSEMBLE LATCH:
 PLACE LIP UNDER OPENING IN END WALL.
 PRESS INTO END WALL UNTIL LATCH CLICKS.

REV	ECO	ISSUE DATE AND DESCRIPTION	DRFT	CHKD
P	89702	JUL 08, 2020 REVISE DRAWING PER NEW HEADER MODEL	JNC	SN
N	68908	AUG 02, 2016 REVISE DIM ON SHT2 & CLIP CHART ON SHT5	JNC	SC
M	56068	AUG 11, 2014 REVISED AND REDRAWN	JNC	RS
CHKD	CASTIGLIONE	DATE AUG 11, 2014	APPRV R. SCHERER	DATE SEP 05, 2014

DESIGN REFERENCE	NEXT ASSEMBLY
DO NOT SCALE DRAWING	SCALE 6/1
THIRD ANGLE PROJECTION	INTERPRET PER ASME Y14.5 - 2018
MAX SURFACE ROUGHNESS	MARKED SURFACES
MARKED ONLY	

DIVISION	Interconnect Solutions	DIVISION CODE	EMSD
TOLERANCES EXCEPT AS NOTED	INCHES: .0 ± .1 .00 ± .01 .000 ± .005 .0000 ± .0002 MILLIMETERS: 0 ± 2 .0 ± .3 .00 ± .13 .000 ± .005		
TITLE	HEADER, 4-WALL, LO-PRO, .100 X .100, SMT, STRAIGHT & RA		
CAGE NUMBER	D78-5100-0770-7	REV.	P
MODEL	2500 SERIES	DET	IS1s YES XNO SHT 6 OF 6

P REVISION
 78-5100-0770-7 DRAWING NUMBER
 B
 C
 D
 A
 Time 9/14/2020 -- UTC
 Drf-set (hrs) 6
 Imaged: Central Standard

Mouser Electronics

Authorized Distributor

Click to View Pricing, Inventory, Delivery & Lifecycle Information:

3M:

[2534-6003UB](#) [2520-5003UG](#) [2526-5003UB](#) [2560-5003UB](#) [2564-6003UB](#) [N2520-6003UB](#) [N2516-5002UB](#) [N2520-6002UG](#) [N2520-60K2UG](#) [N2530-6002UB](#) [N2534-6003UB](#) [N2550-6002UG](#) [N2510-50K2RB](#) [N2510-5002UB](#) [N2510-6002UB](#) [N2510-6002UG](#) [N2510-7003UG](#) [N2514-5002UB](#) [N2514-5003RB](#) [N2516-50K2RB](#) [N2520-50K2RB](#) [N2520-6003RB](#) [N2524-6002UB](#) [N2526-50K2RB](#) [N2526-6002UB](#) [N2530-5003RB](#) [N2530-60K2RB](#) [N2530-6003RB](#) [N2530-6003UB](#) [N2534-5003RB](#) [N2534-6002UB](#) [N2540-5002UB](#) [N2540-5003RB](#) [N2540-60K2RB](#) [N2550-60K2RB](#) [N2550-6002UB](#) [N2550-6003RB](#) [N2564-60K2RB](#) [2540-60K2UB](#) [N2530-50K2RB](#) [N2526-6V0C-RB-WF](#) [2540-6002UG](#) [N2514-6002RB](#) [N2540-6002RB](#) [N2534-5002RB](#) [N2550-6002RB](#) [N2514-5002RB](#) [N2560-6002RB](#) [2510-6003UG](#) [N2526-7002UB](#) [2560-5002UB](#) [2530-5002UB](#) [2520-6002UG](#) [2526-6002UG](#) [2534-6002UG](#) [2514-6002UG](#) [2524-5002UB](#) [2516-5002UG](#) [2560-6003UB](#) [2526-6003RB](#) [2516-6005EB](#) [N2520-5003UB](#) [2526-5002UG](#) [N2510-6003UB](#) [N2514-6002UB](#) [N2526-6003RB](#) [N2534-60K2RB](#) [N2564-6003RB](#) [2510-5002UB](#) [2510-5003UB](#) [2510-60K2UB](#) [2510-6002UB](#) [2510-6002UG](#) [2514-5002UB](#) [2514-5002UG](#) [2514-5003UB](#) [2514-6002UB](#) [2514-6003UB](#) [2514-6003UG](#) [2516-5003UB](#) [2516-5003UG](#) [2516-6002UG](#) [2516-6003UG](#) [2520-5002UG](#) [2520-5003UB](#) [2520-6003UG](#) [2524-6002UG](#) [2524-6003UB](#) [2526-6002UB](#) [2526-6003UG](#) [2530-5003UB](#) [2530-6002UB](#) [2530-6002UG](#) [2534-5002UB](#) [2534-5002UG](#) [2534-5003UB](#) [2540-5002UG](#) [2540-6003UB](#) [2550-5002UG](#) [2550-5003UB](#)