

NOTES:

1. $\text{\textcircled{C}}$ REPRESENTS A CRITICAL DIMENSION.
2. MINIMUM PUSHOUT FORCE TO BE 12 OZ RETENTION FOR CONTACTS AND WELD TABS.
3. MAXIMUM TERMINAL BURR: .003[0.08]
4. MAXIMUM HEIGHT VARIATION BETWEEN ANY TWO PINS: .005[0.13]
5. PARTS SHALL BE PACKAGED IN TUBES UNLESS OTHERWISE SPECIFIED. SEE SHEET 2.
6. NOTE DELETED.
7. NOTE DELETED.
8. ORDERS WILL BE PACKAGED ACCORDING TO THE SAMTEC PACKAGING EFFICIENCY STANDARDS (SPES) FOUND ON WWW.SAMTEC.COM
9. ATTACH LABEL TO EACH REEL.

DO NOT SCALE FROM THIS PRINT

TFM-1XX-XX-X-DH-XX

No OF POSITIONS

-02 THRU -50
(PER ROW)

LEAD STYLE

-02

PACKAGING

BLANK: TUBES (SEE NOTE 5)
-TR: TAPE & REEL PACKAGING (SEE NOTES 8 & 9)
-FR: FULL REEL QTY. TAPE & REEL (SEE NOTES 8 & 9)

ROW SPECIFICATION

-DH: DOUBLE HORIZONTAL

PLATING SPECIFICATION

-S: 30 μ " SELECTIVE GOLD IN CONTACT AREA, MATTE TIN ON TAIL
-L: 10 μ " LIGHT SELECTIVE GOLD IN CONTACT AREA, MATTE TIN ON TAIL
-F: 3 μ " FLASHED SELECTIVE GOLD IN CONTACT AREA, MATTE TIN ON TAIL

TABLE 2

POS	"A"
-02 THRU -30	.004 [0.10]
-31 THRU -50	.006 [0.15]

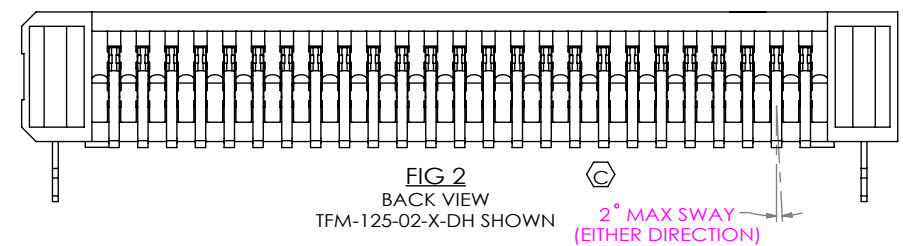
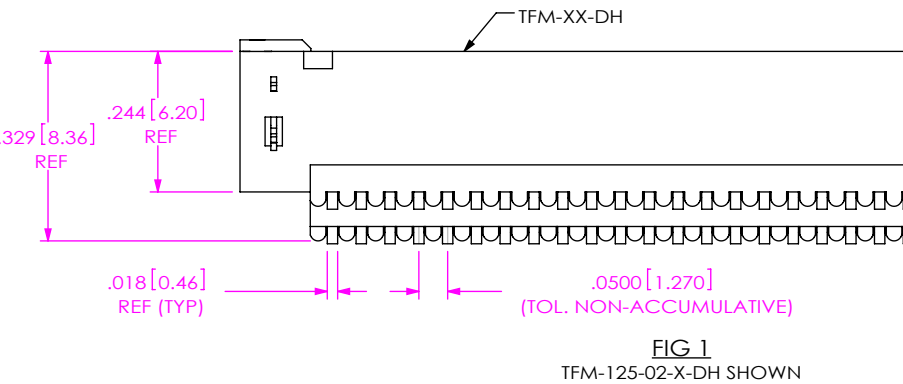
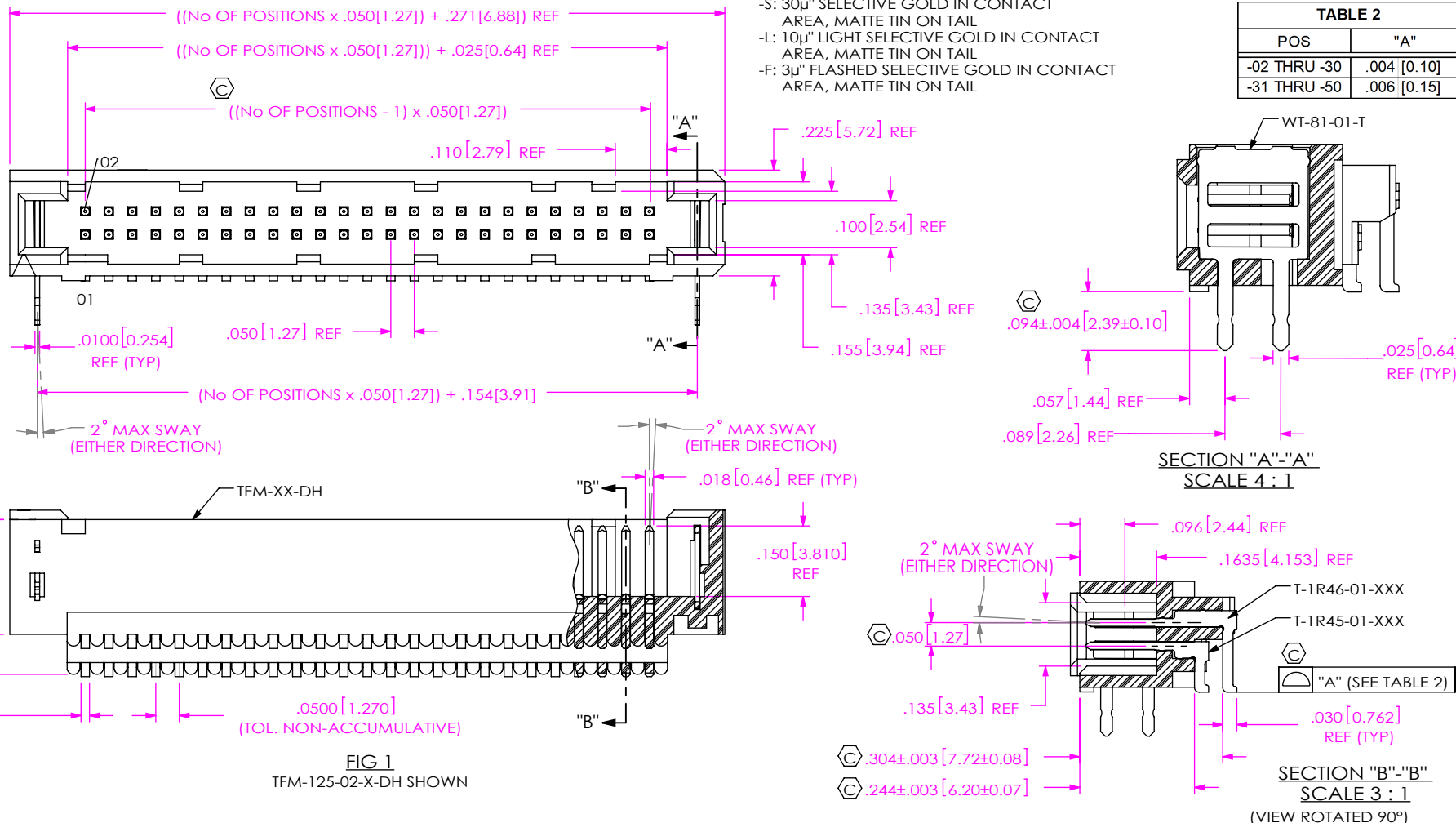

UNLESS OTHERWISE SPECIFIED, DIMENSIONS ARE IN INCHES.
TOLERANCES ARE:
DECIMALS ANGLES
.XX: \pm .01 [0.3] 2°
.XXX: \pm .005 [0.13]
.XXXX: \pm .0020 [0.051]

PROPRIETARY NOTE
THIS DOCUMENT CONTAINS CONFIDENTIAL AND PROPRIETARY INFORMATION AND ALL DESIGN, MANUFACTURING, REPRODUCTION, USE, PATENT RIGHTS AND SALES RIGHTS ARE EXPRESSLY RESERVED BY SAMTEC, INC. THIS DOCUMENT SHALL NOT BE DISCLOSED, IN WHOLE OR PART, TO ANY UNAUTHORIZED PERSON OR ENTITY NOR REPRODUCED, TRANSFERRED OR INCORPORATED IN ANY OTHER PROJECT IN ANY MANNER WITHOUT THE EXPRESS WRITTEN CONSENT OF SAMTEC, INC.



520 PARK EAST BLVD., NEW ALBANY, IN 47150
PHONE: 812-944-6733 FAX: 812-948-5047
e-Mail: info@SAMTEC.com code 55322

MATERIAL: DO NOT SCALE DRAWING SHEET SCALE: 3:1
INSULATOR: LCP, UL 94-VO
COLOR: BLACK
TERMINAL: COPPER ALLOY
F:\DWG\MISC\MKTG\TFM-1XX-XX-X-DH-XX-MKT.SLDDRW

DESCRIPTION: .050 X .050 DOUBLE HORIZONTAL TERMINAL STRIP
DWG. NO. TFM-1XX-XX-X-DH-XX
BY: J. BROWNING 04/12/2010 **SHEET 1 OF 2**

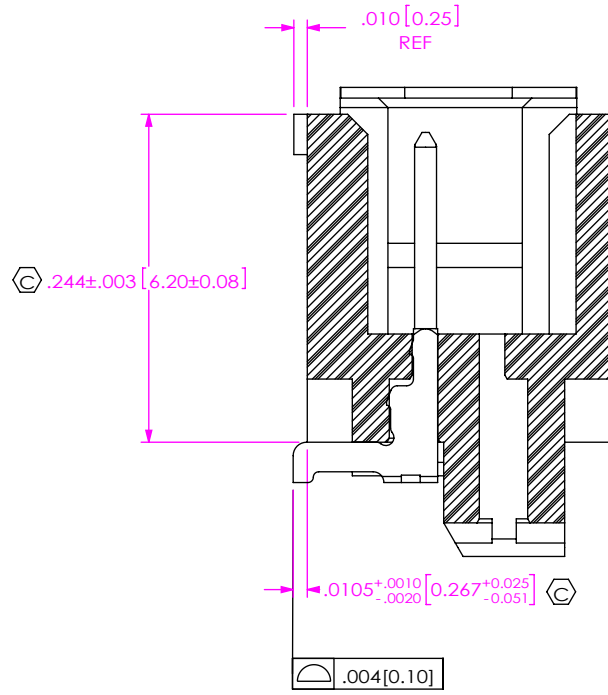

IN-PROCESS 1
FILL T-1R45-01-XXX

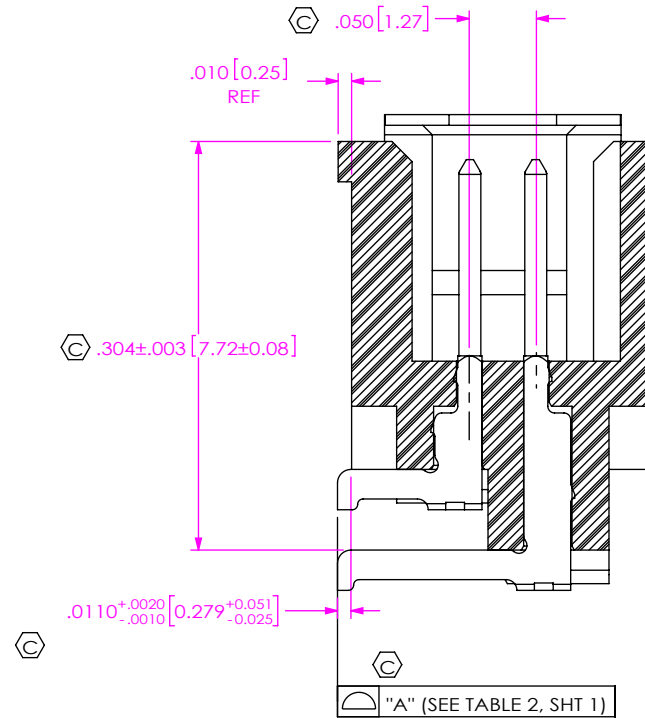

IN-PROCESS 2
FILL T-1R46-01-XXX

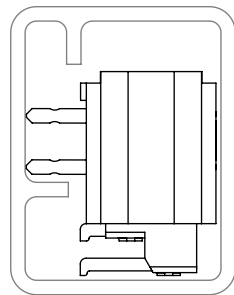

TUBE VIEW
PT-1-24-01-124
TP-07

F:\DWG\MISC\MKTG\TFM-1XX-XX-X-DH-XX-MKT.SLDDRW

PROPRIETARY NOTE
THIS DOCUMENT CONTAINS CONFIDENTIAL AND PROPRIETARY INFORMATION AND ALL DESIGN, MANUFACTURING, REPRODUCTION, USE, PATENT RIGHTS AND SALES RIGHTS ARE EXPRESSLY RESERVED BY SAMTEC, INC. THIS DOCUMENT SHALL NOT BE DISCLOSED, IN WHOLE OR PART, TO ANY UNAUTHORIZED PERSON OR ENTITY NOR REPRODUCED, TRANSFERRED OR INCORPORATED IN ANY OTHER PROJECT IN ANY MANNER WITHOUT THE EXPRESS WRITTEN CONSENT OF SAMTEC, INC.

DO NOT SCALE DRAWING

SHEET SCALE: 3:1



520 PARK EAST BLVD, NEW ALBANY, IN 47150
PHONE: 812-944-6733 FAX: 812-948-5047
e-Mail info@SAMTEC.com code 55322

DESCRIPTION:
.050 X .050 DOUBLE HORIZONTAL TERMINAL STRIP

DWG. NO.
TFM-1XX-XX-X-DH-XX

BY: J. BROWNING 04/12/2010 SHEET 2 OF 2