

ITEM NUMBER	CKT. SIZE	DIM. 'A'	DIM. 'B'	DIM. 'C'	TERMINAL PLATING	CLIP PLATING
42820-2212	2	.138/(3.50)	.823/(20.90)	.071/(1.80)		
42820-2219	2	.136/(3.50)	.823/(20.90)	.071/(1.80)		
42820-2222	2	.201/(5.10)	.823/(20.90)	.102/(2.60)		
42820-2232	2	.201/(5.10)	.823/(20.90)	.134/(3.40)		
42820-2239	2	.201/(5.10)	.823/(20.90)	.134/(3.40)		
42820-2242	2	.327/(8.30)	.823/(20.90)	.259/(6.58)		
42820-3212	3	.138/(3.50)	1.217/(30.90)	.071/(1.80)		
42820-3222	3	.201/(5.10)	1.217/(30.90)	.102/(2.60)		
42820-3229	3	.201/(5.10)	1.217/(30.90)	.102/(2.60)		
42820-3232	3	.201/(5.10)	1.217/(30.90)	.134/(3.40)		
42820-3242	3	.327/(8.30)	1.217/(30.90)	.259/(6.58)		
42820-4212	4	.138/(3.50)	1.610/(40.90)	.071/(1.80)	OVERALL BRIGHT TIN	
42820-4222	4	.201/(5.10)	1.610/(40.90)	.102/(2.60)		
42820-4232	4	.201/(5.10)	1.610/(40.90)	.134/(3.40)		
42820-4242	4	.327/(8.30)	1.610/(40.90)	.259/(6.58)		
42820-5212	5	.138/(3.50)	2.004/(50.90)	.071/(1.80)		
42820-5222	5	.201/(5.10)	2.004/(50.90)	.102/(2.60)		
42820-5232	5	.201/(5.10)	2.004/(50.90)	.134/(3.40)		
42820-5242	5	.327/(8.30)	2.004/(50.90)	.259/(6.58)		
42820-6212	6	.138/(3.50)	2.389/(60.90)	.071/(1.80)		
42820-6222	6	.201/(5.10)	2.389/(60.90)	.102/(2.60)		
42820-6229	6	.201/(5.10)	2.389/(60.90)	.102/(2.60)		
42820-6232	6	.201/(5.10)	2.389/(60.90)	.134/(3.40)		
42820-6242	6	.327/(8.30)	2.389/(60.90)	.259/(6.58)		
42820-2332	2	.201/(5.10)	.823/(20.90)	N/A	NONE	
42820-2342	2	.327/(8.30)	.823/(20.90)	N/A		
42820-2213	2	.138/(3.50)	.823/(20.90)	.071/(1.80)		
42820-2223	2	.201/(5.10)	.823/(20.90)	.102/(2.60)		
42820-2233	2	.201/(5.10)	.823/(20.90)	.134/(3.40)		
42820-2243	2	.327/(8.30)	.823/(20.90)	.259/(6.58)		
42820-3213	3	.138/(3.50)	1.217/(30.90)	.071/(1.80)		
42820-3228	3	.138/(3.50)	1.217/(30.90)	.102/(2.60)		
42820-3223	3	.201/(5.10)	1.217/(30.90)	.102/(2.60)		
42820-3233	3	.201/(5.10)	1.217/(30.90)	.134/(3.40)		
42820-3243	3	.327/(8.30)	1.217/(30.90)	.259/(6.58)		
42820-4213	4	.138/(3.50)	1.610/(40.90)	.071/(1.80)	SELECT GOLD IN CONTACT AREA	
42820-4223	4	.201/(5.10)	1.610/(40.90)	.102/(2.60)	SELECT MATTE TIN ON SOLDER TAILS	
42820-4233	4	.201/(5.10)	1.610/(40.90)	.134/(3.40)		
42820-4243	4	.327/(8.30)	1.610/(40.90)	.259/(6.58)		
42820-5213	5	.138/(3.50)	2.004/(50.90)	.071/(1.80)		
42820-5223	5	.201/(5.10)	2.004/(50.90)	.102/(2.60)		
42820-5233	5	.201/(5.10)	2.004/(50.90)	.134/(3.40)		
42820-5243	5	.327/(8.30)	2.004/(50.90)	.259/(6.58)		
42820-6213	6	.138/(3.50)	2.389/(60.90)	.071/(1.80)		
42820-6223	6	.201/(5.10)	2.389/(60.90)	.102/(2.60)		
42820-6233	6	.201/(5.10)	2.389/(60.90)	.134/(3.40)		
42820-6243	6	.327/(8.30)	2.389/(60.90)	.259/(6.58)		

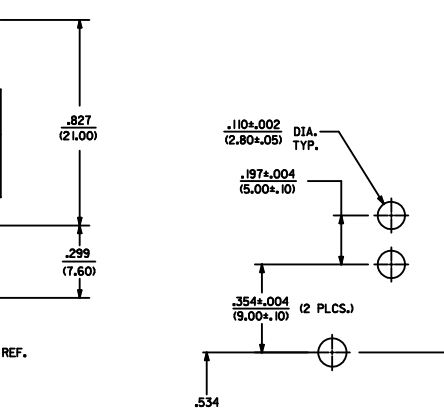

- NOTES:**
- MATERIAL:
HOUSING MATERIAL: 30% GLASS-FILLED NYLON 4/6, U.L. 94V-0, COLOR: BLACK.
TERMINAL MATERIAL: ALLOY 151
 - FINISH: 2= .000100/(.00254) MIN. TIN OVER .000050/(.00127) MIN. NICKEL.
3= .000030/(.00076) MIN. SELECT GOLD IN CONTACT AREA.
.000100/(.00254) MIN. SELECT TIN ON SOLDER TAILS OVER .000050/(.00127) MIN. NICKEL.
 - PRODUCT SPECIFICATION: PS-42815-001
 - PACKAGING INFORMATION: SEE MOLEX PACKAGING SPEC. PK-42820-910
 - PART MATES WITH MOLEX RECEPTACLE *42816-***2 WITH TPA.
 - PART IS DESIGNED IN METRIC.
 - AN 'X' IN FRONT OF THE ITEM NUMBER INDICATES THE PART IS NOT TOOLED.
 - PARTS ARE NOT TO BE MATED OR UNMATED WHILE CIRCUITS ARE LIVE.
 - WHEN USING OVERALL TIN PLATED TERMINALS:
FOR APPLICATIONS INVOLVING VIBRATION AND/OR THERMAL CYCLING, MOLEX STRONGLY RECOMMENDS THE USE OF NYE LUBRICANT (NYGEL 760G) ON THE MATING SURFACES OF THE TERMINAL.
 - PARTS CONFORMS TO CLASS 'B' REQUIREMENTS OF COSMETIC SPECIFICATION PS-45499-002
 - FOR TAPE AND REEL PACKAGING REFER TO PK-45986-004
- △ BOARD CLIP HOLE MAY OR MAY NOT BE PLATED. REFER TO CHART FOR PLATED / UNPLATED CLIPS.

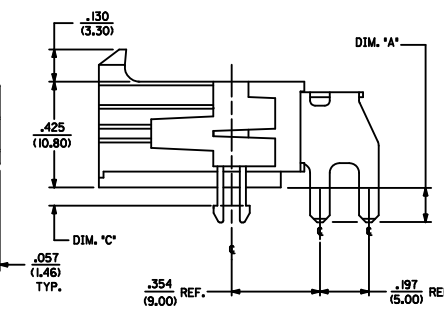
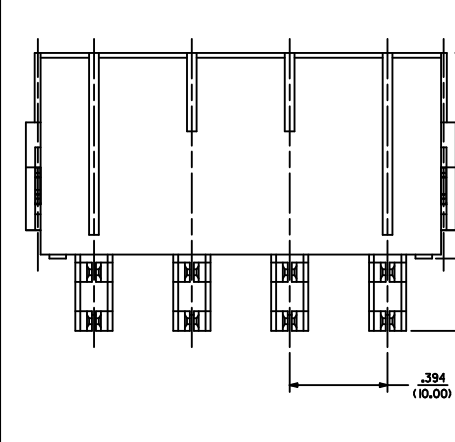
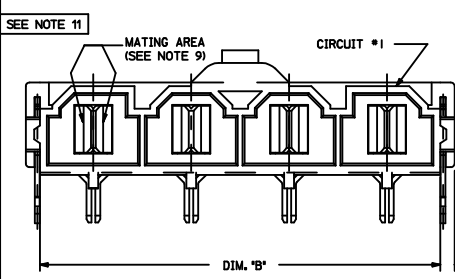
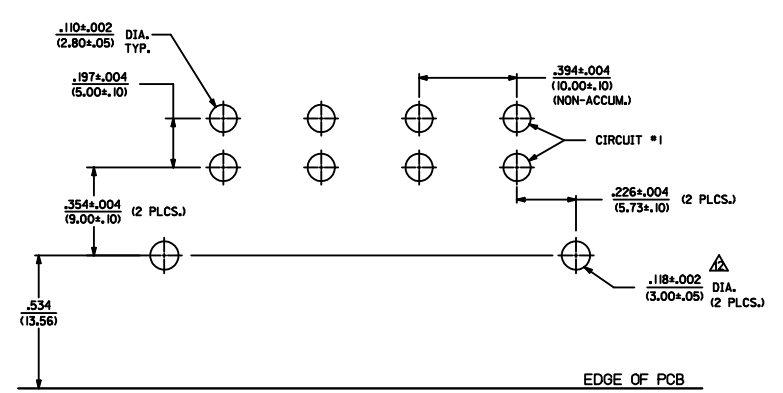

RECOMMENDED P.C. BOARD PLATED-THRU HOLE LAYOUT
(4 CKT. SHOWN FOR REF.)

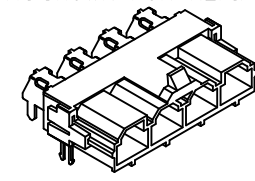

HEADER WITH RT. ANGLE TERMINAL & CLIP
ISO VIEW

LEGEND:
A-42820 - - - -
CIRCUIT SIZE (2-6)

MOUNTING OPTION
1 = FLANGES (SEE DWG. SDA-42820-**) **
2 = RETENTION CLIP
3 = NO RETENTION CLIP

P.C. BOARD THICKNESS
1 = .062/(1.57) NOMINAL
2 = .093/(2.36) NOMINAL
3 = .125/(3.18) NOMINAL
4 = .250/(6.35) NOMINAL

PLATING
2 OR 9= OVERALL BRIGHT TIN OVER NICKEL
3 OR 8= SELECT GOLD IN CONTACT AREA
SELECT MATTE TIN ON SOLDER TAILS OVER NICKEL

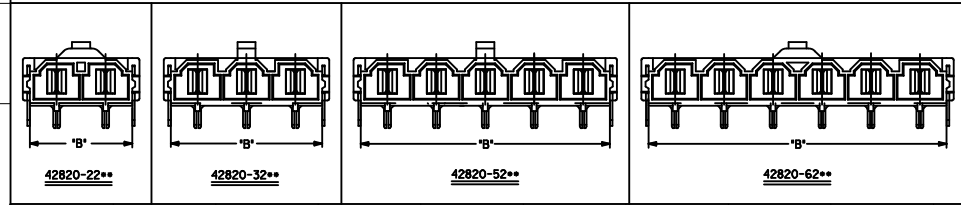

ADD NOTE #12 EC NO. UCP2011-0329 DRAWN: AELHAG 2010/08/05 CHYK: J.BELL 2010/08/05 APPROV: F.S.MITH 2010/08/17	QUALITY SYMBOLS ▽=0 ▽=0	GENERAL TOLERANCES (UNLESS SPECIFIED)		DIMENSION STYLE IN/MM		SCALE 4:1	DESIGN UNITS METRIC	THIRD ANGLE PROJECTION
		4 PLACES ±.005 3 PLACES ±.005 2 PLACES ±0.25 1 PLACE ±0.40	mm INCH	DATE 2010/08/05	DATE 2010/08/05	DATE 2010/08/16	MOLEX MOLEX INCORPORATED	RIGHT ANGLE HEADER ASSEMBLY MINIFIT SR. SERIES
DRAFT WHERE APPLICABLE MUST REMAIN WITHIN DIMENSIONS	SEE CHART	DOCUMENT NO. SDA-42820-0002	THIS DRAWING CONTAINS INFORMATION THAT IS PROPRIETARY TO MOLEX INCORPORATED AND SHOULD NOT BE USED WITHOUT WRITTEN PERMISSION					