

# 74LVQ04

## Low Voltage Hex Inverter

### General Description

The LVQ04 contains six inverters.

### Features

- Ideal for low power/low noise 3.3V applications
- Guaranteed simultaneous switching noise level and dynamic threshold performance
- Guaranteed pin-to-pin skew AC performance
- Guaranteed incident wave switching into 75Ω
- MIL-STD-883 54AC Products are available for Military/Aerospace Applications

### Logic Symbol

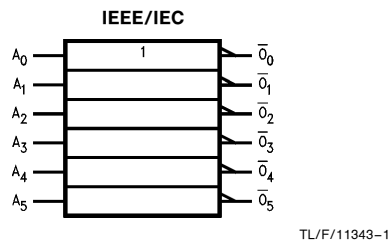

### Connection Diagram

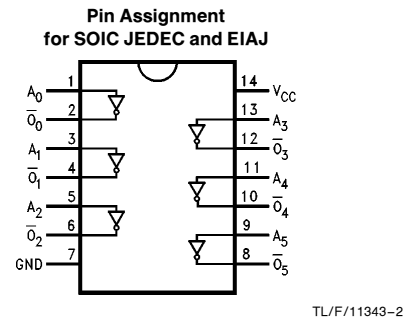

Pin Names	Description
$A_n$	Inputs
$\bar{O}_n$	Outputs

	SOIC JEDEC	SOIC EIAJ
Order Number	74LVQ04SC 74LVQ04SCX	74LVQ04SJ 74LVQ04SJX
See NS Package Number	M14A	M14D

## Absolute Maximum Ratings (Note)

If Military/Aerospace specified devices are required, please contact the National Semiconductor Sales Office/Distributors for availability and specifications.

Supply Voltage ( $V_{CC}$ )	-0.5V to +7.0V
DC Input Diode Current ( $I_{IK}$ )	
$V_I = -0.5V$	-20 mA
$V_I = V_{CC} + 0.5V$	+20 mA
DC Input Voltage ( $V_I$ )	-0.5V to $V_{CC} + 0.5V$
DC Output Diode Current ( $I_{OK}$ )	
$V_O = -0.5V$	-20 mA
$V_O = V_{CC} + 0.5V$	+20 mA
DC Output Voltage ( $V_O$ )	-0.5V to $V_{CC} + 0.5V$
DC Output Source or Sink Current ( $I_O$ )	±50 mA
DC $V_{CC}$ or Ground Current ( $I_{CC}$ or $I_{GND}$ )	±200 mA
Storage Temperature ( $T_{STG}$ )	-65°C to +150°C
DC Latch-Up Source or Sink Current	±100 mA

Note: The "Absolute Maximum Ratings" are those values beyond which the safety of the device cannot be guaranteed. The device should not be operated at these limits. The parametric values defined in the "Electrical Characteristics" table are not guaranteed at the absolute maximum ratings. The "Recommended Operating Conditions" table will define the conditions for actual device operation.

## Recommended Operating Conditions

Supply Voltage ( $V_{CC}$ )	2.0V to 3.6V
LVQ	
Input Voltage ( $V_I$ )	0V to $V_{CC}$
Output Voltage ( $V_O$ )	0V to $V_{CC}$
Operating Temperature ( $T_A$ )	
74LVQ	-40°C to +85°C
Minimum Input Edge Rate ( $\Delta V/\Delta t$ )	
$V_{IN}$ from 0.8V to 2.0V	
$V_{CC}$ @ 3.0V	125 mV/ns

## DC Characteristics

Symbol	Parameter	$V_{CC}$ (V)	74LVQ04		Units	Conditions	
			$T_A = +25^\circ\text{C}$				
			Typ	Guaranteed Limits			
$V_{IH}$	Minimum High Level Input Voltage	3.0	1.5	2.0	2.0	V	$V_{OUT} = 0.1V$ or $V_{CC} - 0.1V$
$V_{IL}$	Maximum Low Level Input Voltage	3.0	1.5	0.8	0.8	V	$V_{OUT} = 0.1V$ or $V_{CC} - 0.1V$
$V_{OH}$	Minimum High Level Output Voltage	3.0	2.99	2.9	2.9	V	$I_{OUT} = -50 \mu\text{A}$
		3.0		2.58	2.48	V	* $V_{IN} = V_{IL}$ or $V_{IH}$ $I_{OH} = -12 \text{ mA}$
$V_{OL}$	Maximum Low Level Output Voltage	3.0	0.002	0.1	0.1	V	$I_{OUT} = 50 \mu\text{A}$
		3.0		0.36	0.44	V	* $V_{IN} = V_{IL}$ or $V_{IH}$ $I_{OL} = 12 \text{ mA}$
$I_{IN}$	Maximum Input Leakage Current	3.6		±0.1	±1.0	μA	$V_I = V_{CC}, \text{ GND}$

\*All outputs loaded; thresholds on input associated with output under test.

## DC Characteristics (Continued)

Symbol	Parameter	V <sub>CC</sub> (V)	74LVQ04		74LVQ04		Units	Conditions
			T <sub>A</sub> = +25°C		T <sub>A</sub> = −40°C to +85°C			
			Typ	Guaranteed Limits				
I <sub>OLD</sub>	† Minimum Dynamic Output Current	3.6			36		mA	V <sub>OLD</sub> = 0.8V Max (Note 1)
I <sub>OHD</sub>		3.6			−25		mA	V <sub>OHD</sub> = 2.0V Min (Note 1)
I <sub>CC</sub>	Maximum Quiescent Supply Current	3.6		2.0	20.0		μA	V <sub>IN</sub> = V <sub>CC</sub> or GND
V <sub>OLP</sub>	Quiet Output Maximum Dynamic V <sub>OL</sub>	3.3	0.8	1.1			V	(Notes 2 & 3)
V <sub>OLV</sub>	Quiet Output Minimum Dynamic V <sub>OL</sub>	3.3	−0.8	−1.1			V	(Notes 2 & 3)
V <sub>IHD</sub>	Maximum High Level Dynamic Input Voltage	3.3	1.7	2.0			V	(Notes 2 & 4)
V <sub>ILD</sub>	Maximum Low Level Dynamic Input Voltage	3.3	1.6	0.8			V	(Notes 2 & 4)

† Maximum test duration 2.0 ms, one output loaded at a time.

**Note 1:** Incident wave switching on transmission lines with impedances as low as 75Ω for commercial temperature range is guaranteed for 74LVQ.

**Note 2:** Worst case package.

**Note 3:** Max number of outputs defined as (n). Data inputs are driven 0V to 3.3V; one output at GND.

**Note 4:** Max number of Data Inputs (n) switching. (n − 1) inputs switching 0V to 3.3V. Input-under-test switching: 3.3V to threshold (V<sub>ILD</sub>) 0V to threshold (V<sub>IHD</sub>) f = 1 MHz.

## AC Electrical Characteristics

Symbol	Parameter	V <sub>CC</sub> (V)	74LVQ04			74LVQ04		Units
			T <sub>A</sub> = +25°C C <sub>L</sub> = 50 pF			T <sub>A</sub> = −40°C to +85°C C <sub>L</sub> = 50 pF		
			Min	Typ	Max	Min	Max	
t <sub>PLH</sub>	Propagation Delay	2.7	1.5	5.4	12.7	1.0	14.0	ns
		3.3 ± 0.3	1.5	4.5	9.0	1.0	10.0	
t <sub>PHL</sub>	Propagation Delay	2.7	1.5	5.4	12.0	1.0	12.0	ns
		3.3 ± 0.3	1.5	4.5	8.5	1.0	9.5	
t <sub>OSHL</sub> , t <sub>OSLH</sub>	Output to Output Skew* Data to Output	2.7 3.3 ± 0.3		1.0 1.0	1.5 1.5		1.5 1.5	ns

\*Skew is defined as the absolute value of the difference between the actual propagation delay for any two separate outputs of the same device. The specification applies to any outputs switching in the same direction, either HIGH to LOW (t<sub>OSHL</sub>) or LOW to HIGH (t<sub>OSLH</sub>). Parameter guaranteed by design.

## Capacitance

Symbol	Parameter	Typ	Units	Conditions
C <sub>IN</sub>	Input Capacitance	4.5	pF	V <sub>CC</sub> = Open
C <sub>PD</sub> (Note 1)	Power Dissipation Capacitance	17	pF	V <sub>CC</sub> = 3.3V

**Note 1:** C<sub>PD</sub> is measured at 10 MHz.

## 74LVQ04 Ordering Information

The device number is used to form part of a simplified purchasing code where the package type and temperature range are defined as follows:

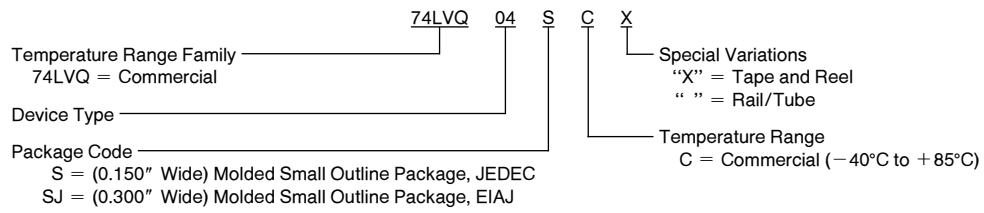

**Physical Dimensions** inches (millimeters) unless otherwise noted

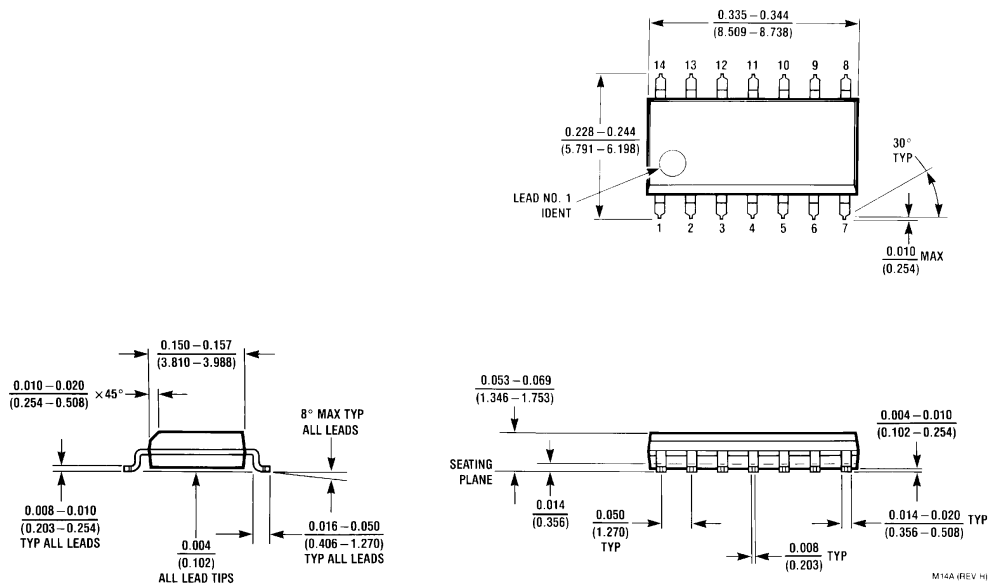

**14-Lead Small Outline Integrated Circuit (S)**  
**Order Number 74LVQ04SC or 74LVQ04SCX**  
**NS Package Number M14A**

**Physical Dimensions** inches (millimeters) unless otherwise noted (Continued)

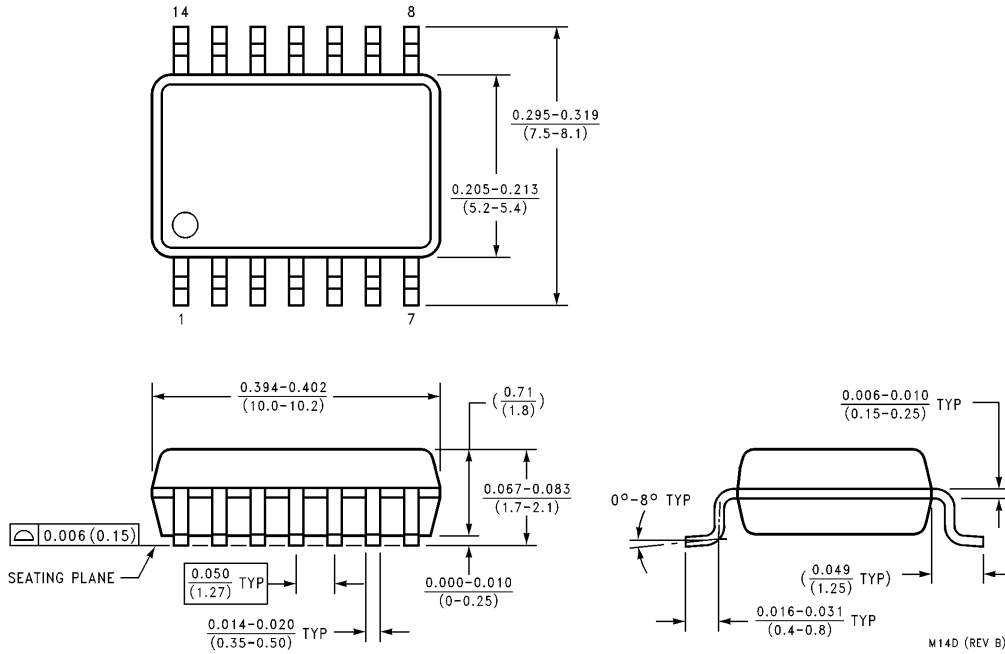

**14-Lead (0.300" Wide) Molded Small Outline Package, EIAJ (SJ)  
Order Number 74LVQ04SJ or 74LVQ04SJX  
NS Package Number M14D**

**LIFE SUPPORT POLICY**

NATIONAL'S PRODUCTS ARE NOT AUTHORIZED FOR USE AS CRITICAL COMPONENTS IN LIFE SUPPORT DEVICES OR SYSTEMS WITHOUT THE EXPRESS WRITTEN APPROVAL OF THE PRESIDENT OF NATIONAL SEMICONDUCTOR CORPORATION. As used herein:

1. Life support devices or systems are devices or systems which, (a) are intended for surgical implant into the body, or (b) support or sustain life, and whose failure to perform, when properly used in accordance with instructions for use provided in the labeling, can be reasonably expected to result in a significant injury to the user.
2. A critical component is any component of a life support device or system whose failure to perform can be reasonably expected to cause the failure of the life support device or system, or to affect its safety or effectiveness.

	<b>National Semiconductor Corporation</b> <b>Americas</b> Tel: 1(800) 272-9959 Fax: 1(800) 737-7018 Email: support@nsc.com	<b>National Semiconductor Europe</b> Fax: +49 (0) 180-530 85 86 Email: europe.support@nsc.com Deutsch Tel: +49 (0) 180-530 85 85 English Tel: +49 (0) 180-532 78 32 Français Tel: +49 (0) 180-532 93 58 Italiano Tel: +49 (0) 180-534 16 80	<b>National Semiconductor Southeast Asia</b> Fax: (852) 2376 3901 Email: sea.support@nsc.com	<b>National Semiconductor Japan Ltd.</b> Tel: 81-3-5620-7561 Fax: 81-3-5620-6179
	<a href="http://www.national.com">http://www.national.com</a>			
	National does not assume any responsibility for use of any circuitry described, no circuit patent licenses are implied and National reserves the right at any time without notice to change said circuitry and specifications.			

This datasheet has been download from:

[www.datasheetcatalog.com](http://www.datasheetcatalog.com)

Datasheets for electronics components.