

74LS244, S244 Buffers

Octal Buffers (3-State)
Product Specification

Logic Products

FUNCTION TABLE

INPUTS				OUTPUTS	
\overline{OE}_a	I_a	\overline{OE}_b	I_b	Y_a	Y_b
L	L	L	L	L	L
L	H	L	H	H	H
H	X	H	X	(Z)	(Z)

H = HIGH voltage level
L = LOW voltage level
X = Don't care
(Z) = HIGH impedance (off) state

TYPE	TYPICAL PROPAGATION DELAY	TYPICAL SUPPLY CURRENT (TOTAL)
74LS244	12ns	25mA
74S244	6ns	112mA

ORDERING CODE

PACKAGES	COMMERCIAL RANGE $V_{CC} = 5V \pm 5\%$; $T_A = 0^\circ C$ to $+70^\circ C$
Plastic DIP	N74LS244N, 74S244N
Plastic SOL-20	74LS244D

NOTE:

For information regarding devices processed to Military Specifications, see the Signetics Military Products Data Manual.

INPUT AND OUTPUT LOADING AND FAN-OUT TABLE

PINS	DESCRIPTION	74S	74LS
All	Inputs	1Sul	1LSul
All	Outputs	24Sul	30LSul

NOTE:

A 74S unit load (Sul) is $50\mu A$ I_{IH} and $-2.0mA$ I_{IL} , and a 74LS unit load (LSul) is $20\mu A$ I_{IH} and $-0.4mA$ I_{IL} .

PIN CONFIGURATION

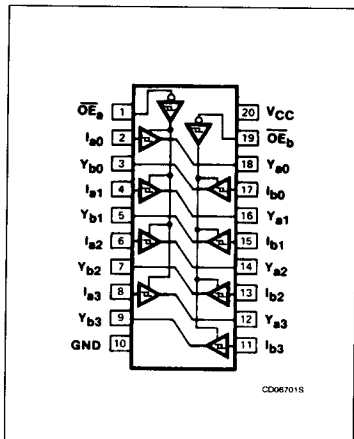

December 4, 1985

LOGIC SYMBOL

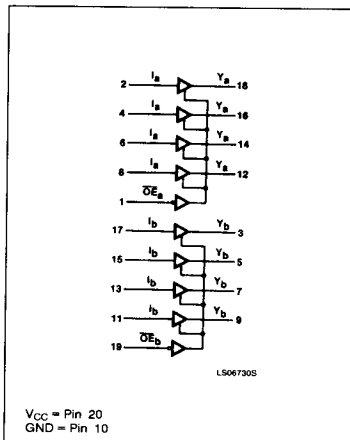

5-420

LOGIC SYMBOL (IEEE/IEC)

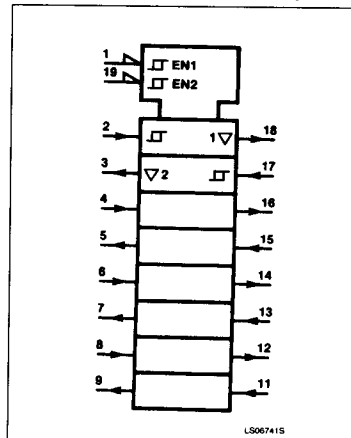

853-0461 81500

Buffers

74LS244, S244

ABSOLUTE MAXIMUM RATINGS (Over operating free-air temperature range unless otherwise noted.)

PARAMETER	74LS	74S	UNIT
V _{CC} Supply voltage	7.0	7.0	V
V _{IN} Input voltage	-0.5 to +7.0	-0.5 to +5.5	V
I _{IN} Input current	-30 to +1	-30 to +5	mA
V _{OUT} Voltage applied to output in HIGH output state	-0.5 to +V _{CC}	-0.5 to +V _{CC}	V
T _A Operating free-air temperature range	0 to 70		°C

RECOMMENDED OPERATING CONDITIONS

PARAMETER	74LS			74S			UNIT
	Min	Nom	Max	Min	Nom	Max	
V _{CC} Supply voltage	4.75	5.0	5.25	4.75	5.0	5.25	V
V _{IH} HIGH-level input voltage	2.0			2.0			V
V _{IL} LOW-level input voltage			+0.8			+0.8	V
I _{IK} Input clamp current			-18			-18	mA
I _{OH} HIGH-level output current			-15			-15	mA
I _{OL} LOW-level output current			24			64	mA
T _A Operating free-air temperature	0		70	0		70	°C

TEST CIRCUITS AND WAVEFORMS

Test Circuit For 3-State Outputs

Input Pulse Definition

$V_M = 1.3V$ for 74LS; $V_M = 1.5V$ for all other TTL families.

SWITCH POSITION

TEST	SWITCH 1	SWITCH 2
t _{PZH}	Open	Closed
t _{PZL}	Closed	Open
t _{PHZ}	Closed	Closed
t _{PLZ}	Closed	Closed

DEFINITIONS
R_L = Load resistor to V_{CC}; see AC CHARACTERISTICS for value.
C_L = Load capacitance includes jig and probe capacitance; see AC CHARACTERISTICS for value.
R_T = Termination resistance should be equal to Z_{OUT} of Pulse Generators.
D = Diodes are 1N916, 1N3064, or equivalent.
R_X = 1kΩ for 74, 74S, R_X = 5kΩ for 74LS.
t_{TLH}, t_{THL} Values should be less than or equal to the table entries.

FAMILY	INPUT PULSE REQUIREMENTS				
	Amplitude	Rep. Rate	Pulse Width	t _{TLH}	t _{THL}
74	3.0V	1MHz	500ns	7ns	7ns
74LS	3.0V	1MHz	500ns	15ns	6ns
74S	3.0V	1MHz	500ns	2.5ns	2.5ns

Buffers

74LS244, S244

DC ELECTRICAL CHARACTERISTICS (Over recommended operating free-air temperature range unless otherwise noted.)

PARAMETER	TEST CONDITIONS ¹	74LS244			74S244			UNIT
		Min	Typ ²	Max	Min	Typ ²	Max	
ΔV_T Hysteresis ($V_{T+} - V_{T-}$)	$V_{CC} = \text{MIN}$	0.2	0.4		0.2	0.4		V
V_{OH} HIGH-level output voltage	$V_{CC} = \text{MIN}, V_{IH} = \text{MIN}, V_{IL} = 0.5V, I_{OH} = \text{MAX}$	2.0			2.0			V
	$V_{CC} = \text{MIN}, V_{IH} = \text{MIN}, V_{IL} = \text{MAX}, I_{OH} = \text{MAX}$	2.4	3.4		2.4			V
V_{OL} LOW-level output voltage	$V_{CC} = \text{MIN}, V_{IH} = \text{MIN}, V_{IL} = \text{MAX}$			0.5			0.55	V
	$I_{OL} = \text{MAX}$ $I_{OL} = 12\text{mA}$ (74LS)			0.4				V
V_{IK} Input clamp voltage	$V_{CC} = \text{MIN}, I_I = I_{IK}$			-1.5			-1.2	V
I_{OZH} Off-state output current, HIGH-level voltage applied	$V_{CC} = \text{MAX}, V_{IH} = \text{MIN}, V_{IL} = \text{MAX}$			20				μA
	$V_O = 2.7V$ $V_O = 2.4V$						50	μA
I_{OZL} Off-state output current, LOW-level voltage applied	$V_{CC} = \text{MAX}, V_{IH} = \text{MIN}, V_{IL} = \text{MAX}$			-20				μA
	$V_O = 0.4V$ $V_O = 0.5V$						-50	μA
I_I Input current at maximum input voltage	$V_{CC} = \text{MAX}$						1.0	mA
	$V_I = 5.5V$ $V_I = 7.0V$			0.1				mA
I_{IH} HIGH-level input current	$V_{CC} = \text{MAX}, V_I = 2.7V$			20			50	μA
I_{IL} LOW-level input current	$V_{CC} = \text{MAX}$			-0.2				mA
	$V_I = 0.5V$						-2.0	mA
I_{OS} Short-circuit output current ³	$V_{CC} = \text{MAX}$			-40	-130	-80	-180	mA
	$V_{CC} = \text{MAX}$							mA
I_{CC} Supply current ⁴ (total)	I_{CCH} Outputs HIGH		17	27		95	160	mA
	I_{CCL} Outputs LOW		27	46		120	180	mA
	I_{CCZ} Outputs OFF		32	54		120	180	mA

NOTES:

- For conditions shown as MIN or MAX, use the appropriate value specified under recommended operating conditions for the applicable type.
- All typical values are at $V_{CC} = 5V, T_A = 25^\circ\text{C}$.
- I_{OS} is tested with $V_{OUT} = +0.5V$ and $V_{CC} = V_{CC} \text{ MAX} + 0.5V$. Not more than one output should be shorted at a time and duration of the short circuit should not exceed one second.
- I_{CC} is measured with outputs open.

AC ELECTRICAL CHARACTERISTICS $T_A = 25^\circ\text{C}, V_{CC} = 5.0V$

PARAMETER	TEST CONDITIONS	74LS		74S		UNIT
		$C_L = 45\text{pF}, R_L = 667\Omega$		$C_L = 50\text{pF}, R_L = 90\Omega$		
		Min	Max	Min	Max	
t_{PLH} Propagation delay	Waveform 1		18		9	ns
t_{PHL} Propagation delay	Waveform 1		18		9	ns
t_{PZH} Enable to HIGH	Waveform 2		23		12	ns
t_{PZL} Enable to LOW	Waveform 3		30		15	ns
t_{PHZ} Disable from HIGH	Waveform 2, $C_L = 5\text{pF}$		18		9	ns
t_{PLZ} Disable from LOW	Waveform 3, $C_L = 5\text{pF}$		25		15	ns

Buffers

74LS244, S244

AC WAVEFORMS

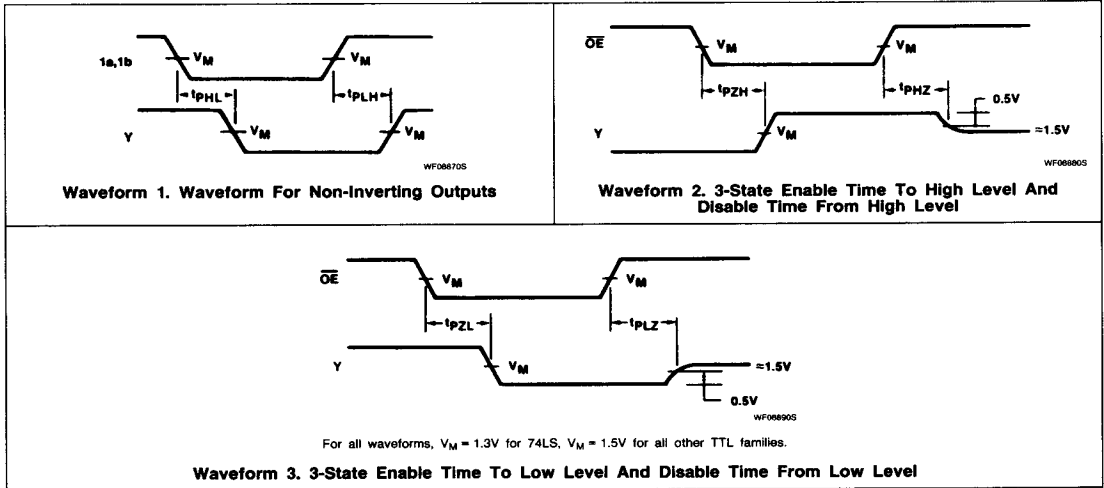

5