



# BCM3116 PRODUCT Brief



## BCM3116 QAMLINK™ DOCSIS RECEIVER

### BCM3116 FEATURES

- **Downstream QAM Receiver for North American set-top box and DOCSIS cable modem applications.**
- **Integrated QAMLink receiver with forward error correction (FEC)**
  - 5.059641/5.360537 MBaud variable symbol rate
  - Supports 64 and 256-QAM
  - Digital demodulator, Nyquist filters, tracking loops, and 32-tap adaptive decision feedback equalizer
  - Digital derotator for wideband carrier phase tracking
- **ITU-T J.83 Annex B-compliant FEC decoder**
  - 16-state trellis decoder
  - Reed-Solomon (n,k) = (128,122); t = 3
  - Programmable convolutional deinterleaver, I\*J < 128 with internal RAM, I\*J > 128 with external RAM
- **IC or SPI-compatible microcontroller interface**
- **On-chip generation of all clock and control signals**
- **3.3V operation**
- **JTAG Test Interface**
- **100-pin PQFP**

### SUMMARY OF BENEFITS

- **Fully-integrated, DOCSIS-compliant solution for cable modems and cable-TV set-top boxes**
  - Enables the industry's lowest cost, least complex system
  - Simplifies system, board and software design through the integration of analog components
  - Reduces power consumption
- **Enhanced digital adaptive equalization**
  - Robust performance in the presence of multipath at high order QAM constellations
  - Superior echo cancellation capability for both wired and wireless applications
- **Seamless integration with key subscriber cable modem components:**
  - BCM3037: QAMLink QPSK/16-QAM Burst Modulator
  - BCM3220: QAMLink Media Access Controller (MAC)

DOCSIS-compliant Cable Modem Block Diagram

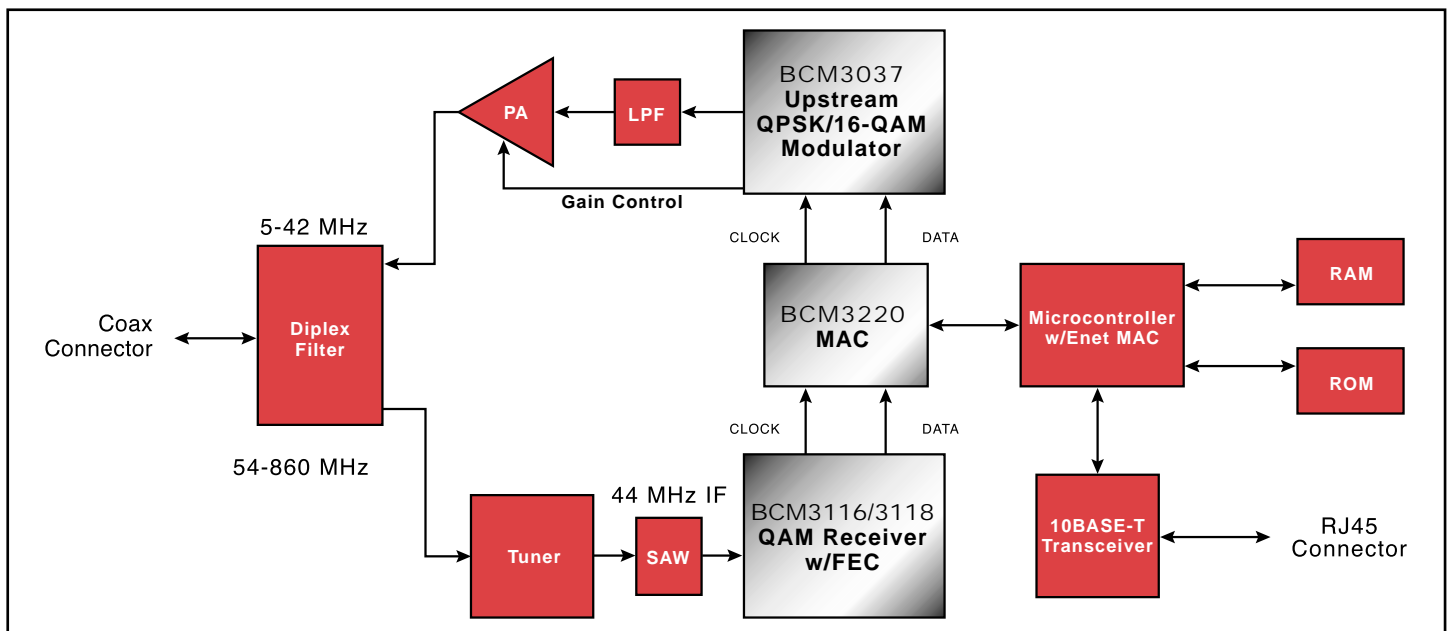

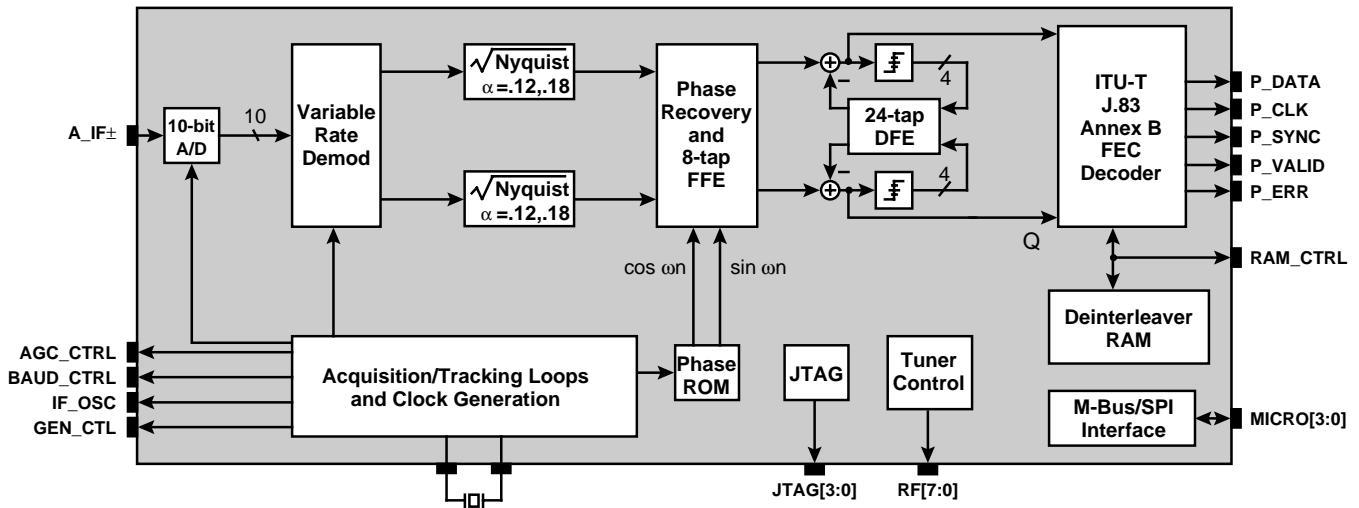

The **BCM3116** QAMLink Receiver is a fully asynchronous design with an integrated FEC and 10-bit analog-to-digital converter. It provides a complete digital transmission solution for cable modems, cable-TV set-top boxes and digital microwave radios. Its bandwidth-efficient feature set expands the existing potential bandwidth of a standard analog network and provides operators with reliable, error-free transmission.

The **BCM3116** accepts a modulated data stream at up to 38.8 Mbps and delivers a demodulated, equalized and error-corrected output data stream. The receiver integrates a 10-bit A/D converter, a 256-QAM demodulator with square-root raised-cosine receive filters, a 32-tap adaptive equalizer with an embedded phase recovery derotator, acquisition and tracking loops, and a forward error correction (FEC) decoder. The FEC is ITU-T J.83 Annex B, DOCSIS, DigiCipher II®, IEEE 802.14, and SCTE DVS-031-compliant.

The analog IF waveform is fed into the chip, where it is sampled by the integrated A/D converter, digitally mixed to baseband and filtered by dual square-root Nyquist filters. Inter-symbol interference is then removed by the adaptive decision feedback equalizer (DFE). A decision slicer, which supports constellations up to 256-QAM, formats the equalized data which is then fed into a trellis decoder, derandomizer, deinterleaver, and Reed-Solomon decoder. The final error-corrected output is delivered in non-MPEG or in MPEG-2 transport format.

Optimized for high-volume manufacturing, the **BCM3116** represents a highly integrated solution that reduces the system-level chip count, the cost and the complexity associated with manufacturing RF receivers. When combined with the BCM3037 QAMLink QPSK/16-QAM Burst Modulator and the BCM3220 QAMLink Cable Modem MAC, the **BCM3116** is an ideal solution for two-way RF cable set-top boxes and cable modems.

Broadcom® and the pulse logo are registered trademarks of Broadcom Corporation.  
 QAMLink is a trademark of Broadcom Corporation.  
 DigiCipherII is a registered trademark of General Instrument Corporation.

For more information please contact us at:  
 Phone: 949-450-8700, FAX: 949-450-8710  
 Email: info@broadcom.com



Visit our web site at: [www.broadcom.com](http://www.broadcom.com)

© 2000 BROADCOM CORPORATION

3116-PB02-R-04.24.01

BROADCOM CORPORATION  
 16215 Alton Parkway, P.O. Box 57013  
 Irvine, California 92619-7013