

REVISIONS			
REV	DESCRIPTION	DATE	APPROVED

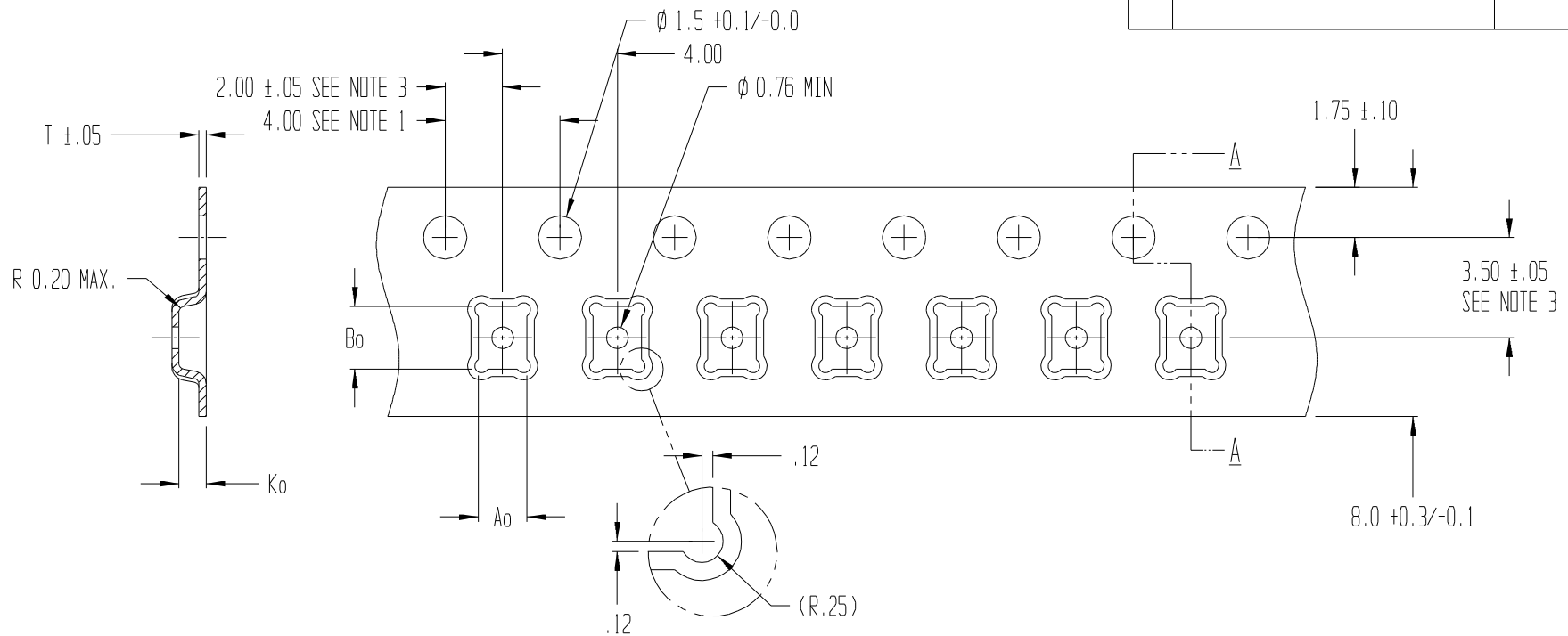

SECTION A - A

$A_o = 1.70$
 $B_o = 2.20$
 $K_o = 0.95$

PART #	T	MATERIAL	DWG #
ABA029-BC	0.30	PS+C	T106596BT
ABA029-BI	0.25	PS+C	T108690BT

NOTES:

1. 10 SPROCKET HOLE PITCH CUMULATIVE TOLERANCE ± 0.2
2. CAMBER IN COMPLIANCE WITH EIA 481
3. POCKET POSITION RELATIVE TO SPROCKET HOLE MEASURED AS TRUE POSITION OF POCKET, NOT POCKET HOLE
4. A_o AND B_o ARE CALCULATED ON A PLANE AT A DISTANCE "R" ABOVE THE BOTTOM OF THE POCKET.



TITLE ADVANTEK PART DRAWING NUMBER ABA029-B CARRIER TAPE			
TOLERANCES - UNLESS NOTED 1PL ± 0.2 2PL ± 0.10	MATERIAL SEE TABLE	DWG SIZE B	
ALL DIMS IN MILLIMETERS PER ASME Y14.5M			
DRAWN BY BTH/ AVF	DATE 01/11/2011	SCALE 6:1	SHEET 1 OF 1
CK'D BY	PROJECT NO. 3489.02	DWG NO. SEE TABLE	REV