

DM74AS573 Octal D-Type Transparent Latch with TRI-STATE® Outputs

General Description

These 8-bit registers feature totem-pole TRI-STATE outputs designed specifically for driving highly-capacitive or relatively low-impedance loads. The high-impedance state and increased high-logic-level drive provide these registers with the capability of being connected directly to and driving the bus lines in a bus-organized system without need for interface or pull-up components. They are particularly attractive for implementing buffer registers, I/O ports, bidirectional bus drivers, and working registers.

The eight latches of the AS573 are transparent D-type latches, meaning that while the enable (G) is high the Q outputs will follow the data (D) inputs. When the enable is taken low the output will be latched at the level of the data that was set up.

A buffered output control input can be used to place the eight outputs in either a normal logic state (high or low logic levels) or a high-impedance state. In the high-impedance state the outputs neither load nor drive the bus lines significantly.

The output control does not affect the internal operation of the latches. That is, the old data can be retained or new data can be entered even while the outputs are off.

The pin-out is arranged to ease printed circuit board layout. All data inputs are on one side of the package while all the outputs are on the other side.

Features

- Switching specifications at 50 pF
- Switching specifications guaranteed over full temperature and V_{CC} range
- Advanced oxide-isolated, ion-implanted Schottky TTL process
- Functionally equivalent with S373
- Improved AC performance over S373 at approximately half the power
- TRI-STATE buffer-type outputs drive bus lines directly
- Bus structured pinout

Connection Diagram

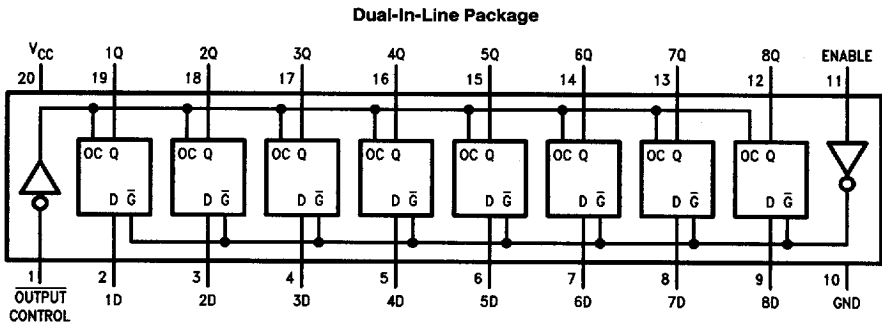

TL/F/6313-1

Absolute Maximum Ratings

Supply Voltage	7V
Input Voltage	7V
Voltage Applied to Disabled Output	5.5V
Operating Free Air Temperature Range	0°C to +70°C
Storage Temperature Range	-65°C to +150°C
Typical θ_{JA}	
N Package	52.0°C/W
M Package	70.0°C/W

Note: The "Absolute Maximum Ratings" are those values beyond which the safety of the device cannot be guaranteed. The device should not be operated at these limits. The parametric values defined in the "Electrical Characteristics" table are not guaranteed at the absolute maximum ratings. The "Recommended Operating Conditions" table will define the conditions for actual device operation.

Recommended Operating Conditions

Symbol	Parameter	Min	Nom	Max	Units
V_{CC}	Supply Voltage	4.5	5	5.5	V
V_{IH}	High Level Input Voltage	2			V
V_{IL}	Low Level Input Voltage			0.8	V
I_{OH}	High Level Output Current			-15	mA
I_{OL}	Low Level Output Current			48	mA
t_w	Width of Enable Pulse	High	4.5		ns
		Low	5.5		
t_{SU}	Data Setup Time	2 \uparrow			ns
t_H	Data Hold Time	3 \uparrow			ns
T_A	Free Air Operating Temperature	0		70	°C

The (\uparrow) arrow indicates the positive edge of the Clock is used for reference.

Electrical Characteristics

over recommended operating free air temperature range. All typical values are measured at $V_{CC} = 5V$, $T_A = 25^\circ C$.

Symbol	Parameter	Conditions	Min	Typ	Max	Units
V_{IK}	Input Clamp Voltage	$V_{CC} = 4.5V$, $I_I = -18 mA$			-1.2	V
V_{OH}	High Level Output Voltage	$V_{CC} = 4.5V$, $V_{IL} = \text{Max}$, $I_{OH} = \text{Max}$	2.4	3.3		V
		$V_{CC} = 4.5V$ to $5.5V$, $I_{OH} = -2 mA$	$V_{CC} - 2$			
V_{OL}	Low Level Output Voltage	$V_{CC} = 4.5V$, $V_{IH} = 2V$ $I_{OL} = \text{Max}$		0.35	0.5	V
I_I	Input Current @ Max Input Voltage	$V_{CC} = 5.5V$, $V_{IH} = 7V$			0.1	mA
I_{IH}	High Level Input Current	$V_{CC} = 5.5V$, $V_{IH} = 2.7V$			20	μA
I_{IL}	Low Level Input Current	$V_{CC} = 5.5V$, $V_{IL} = 0.4V$			-0.5	mA
I_O (Note 1)	Output Drive Current	$V_{CC} = 5.5V$, $V_O = 2.25V$	-30		-112	mA
I_{OZH}	Off-State Output Current, High Level Voltage Applied	$V_{CC} = 5.5V$, $V_{IH} = 2V$, $V_O = 2.7V$			50	μA
I_{OZL}	Off-State Output Current, Low Level Voltage Applied	$V_{CC} = 5.5V$, $V_{IH} = 2V$, $V_O = 0.4V$			-50	μA
I_{CC}	Supply Current	$V_{CC} = 5.5V$ Outputs Open	Outputs High	56	93	mA
			Outputs Low	55	90	
			Outputs Disabled	65	106	

Note 1: The output conditions have been chosen to produce a current that approximates one half of the true short-circuit output current, I_{OS} .

Switching Characteristics over recommended operating free air temperature range (Note 1)

Symbol	Parameter	Conditions	From	To	Min	Max	Units
t _{PLH}	Propagation Delay Time Low to High Level Output	V _{CC} = 4.5V to 5.5V R _L = 500Ω C _L = 50 pF	Data	Any Q	3	6	ns
t _{PHL}	Propagation Delay Time High to Low Level Output		Data	Any Q	3	6	ns
t _{PLH}	Propagation Delay Time Low to High Level Output		Enable	Any Q	6	11.5	ns
t _{PHL}	Propagation Delay Time High to Low Level Output		Enable	Any Q	4	7.5	ns
t _{PZH}	Output Enable Time to High Level Output		$\overline{\text{Output Control}}$	Any Q	2	6.5	ns
t _{PZL}	Output Enable Time to Low Level Output		$\overline{\text{Output Control}}$	Any Q	4	9.5	ns
t _{PHZ}	Output Disable Time from High Level Output		$\overline{\text{Output Control}}$	Any Q	2	6.5	ns
t _{PLZ}	Output Disable Time from Low Level Output		$\overline{\text{Output Control}}$	Any Q	2	7	ns

Note 1: See Section 5 for test waveforms and output load.

Function Table

Output Control	Enable G	D	Output Q
L	H	H	H
L	H	L	L
L	L	X	Q ₀
H	X	X	Z

L = Low State, H = High State, X = Don't Care

Z = High Impedance State

Q₀ = Previous Condition of Q

Logic Diagram

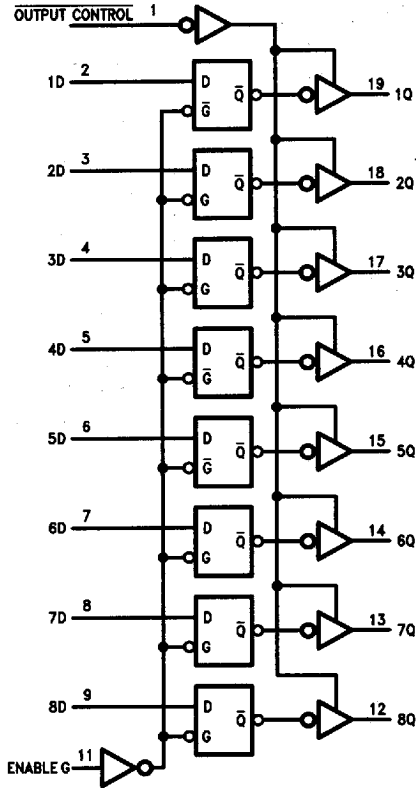

TL/F/6313-2