

GD54/74HC04, GD54/74HCT04

HEX INVERTERS

General Description

These devices are identical in pinout to the 54/74LS04. They contain six independent inverters. These devices are characterized for operation over wide temperature ranges to meet industry and military specifications.

Features

- Low Power consumption characteristic of CMOS devices
- Output drive capability: 10 LS TTL Loads Min.
- Operating speed superior to LS TTL
- Wide operating voltage range: for HC 2 to 6 volts
for HCT 4.5 to 5.5 volts
- Low input current: 1 μ A Max.
- Low quiescent current: 20 μ A Max. (74HC)
- High noise immunity characteristic of CMOS
- Diode protection on all inputs

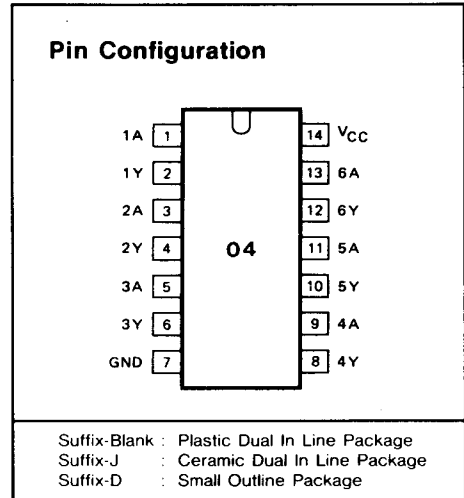

Logic Diagram

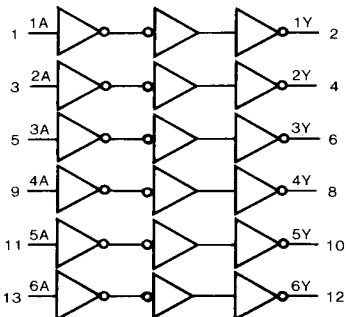

Fig. 1 Logic diagram

Function Table

INPUT	OUTPUT
nA	nY
L	H
H	L

H=HIGH Voltage level
 L=LOW Voltage level

Absolute Maximum Ratings

SYMBOL	PARAMETER	CONDITIONS	MIN.	MAX.	UNIT
V_{CC}	DC Supply voltage		-0.5	+7	V
I_{IK}, I_{OK}	DC input or output diode current	for $V_I < -0.5$ or $V_I > V_{CC} + 0.5V$		20	mA
I_O	DC output source or sink current	for $-0.5V < V_O < V_{CC} + 0.5V$		25	mA
I_{CC}	DC V_{CC} or GND current			50	mA
T_{stg}	Storage temperature range		-65	150	°C
P_D	Power dissipation per package	above +70°C: derate linearly with 8mW/K		500	mW
T_L	Lead temperature	At distance 1/16 ± 1/32 in. from case for 60 sec(CERAMIC) 10 sec(PLASTIC)		300 260	°C

Recommended Operating Conditions

CHARACTERISTIC	LIMITS		UNITS
	MIN.	MAX.	
Supply-Voltage Range V_{CC} : GD54/74HC Types GD54/74HCT Types	2 4.5	6 5.5	V
DC Input or Output Voltage V_I, V_O	0	V_{CC}	V
Operating Temperature T_A : GD74 Types GD54 Types	-40 -55	+85 +125	°C
Input Rise and Fall times t_r, t_f : GD54/74HC Types at 2V at 4.5V at 6V GD54/74HCT Types at 4.5V		1000 500 400 500	ns

DC Electrical Characteristics for HC

SYMBOL	PARAMETER	TEST CONDITION	V _{CC} (V)	T _A =25°C			GD74HC04		GD54HC04		UNIT	
				MIN.	TYP.	MAX.	MIN.	MAX.	MIN.	MAX.		
V _{IH}	HIGH level input Voltage		2.0	1.5			1.5		1.5		V	
			4.5	3.15			3.15		3.15			
			6.0	4.2			4.2		4.2			
V _{IL}	LOW level input voltage		2.0			0.3		0.3		0.3	V	
			4.5			0.9		0.9		0.9		
			6.0			1.2		1.2		1.2		
V _{OH}	HIGH level output voltage	V _{IN} =V _{IH}	I _{OH} =-20μA	2.0	1.9	2.0		1.9		1.9	V	
				4.5	4.4	4.5		4.4		4.4		
				6.0	5.9	6.0		5.9		5.9		
		or V _{IL}	I _{OH} =-4mA I _{OH} =-5.2mA	4.5	3.98	4.3		3.84		3.7		
				6.0	5.48	5.2		5.34		5.2		
V _{OL}	LOW level output voltage	V _{IN} =V _{IH}	I _{OL} =20μA	2.0			0.1		0.1		V	
				4.5			0.1		0.1			0.1
				6.0			0.1		0.1			0.1
		or V _{IL}	I _{OL} =4mA I _{OL} =5.2mA	4.5		0.17	0.26		0.33			0.4
				6.0		0.15	0.26		0.33			0.4
I _{IN}	Input leakage Current	V _{IN} =V _{CC} or GND	6.0			0.1		1.0		1.0	μA	
I _{CC}	Quiescent Supply Current	V _{IN} =V _{CC} or GND I _{out} =0μA	6.0			2		20		40	μA	

DC Electrical Characteristics for HCT

SYMBOL	PARAMETER	TEST CONDITION	V _{CC} (V)	T _A =25°C			GD74HCT04		GD54HCT04		UNIT	
				MIN.	TYP.	MAX.	MIN.	MAX.	MIN.	MAX.		
V _{IH}	HIGH level input Voltage		4.5	2.0			2.0		2.0		V	
			to 5.5									
V _{IL}	LOW level input voltage		4.5			0.8		0.8		0.8	V	
			to 5.5									
V _{OH}	HIGH level output voltage	V _{IN} =V _{IH}	I _{OH} =-20μA	4.5	4.4	4.5		4.4		4.4	V	
				or V _{IL}	I _{OH} =-4mA	4.5	3.98	4.3		3.84		
		or V _{IL}	I _{OH} =-4mA	4.5			0.1		0.1			0.1
				4.5		0.17	0.26		0.33			0.4
I _{IN}	Input leakage Current	V _{IN} =V _{CC} or GND	5.5			0.1		1.0		1.0	μA	
I _{CC}	Quiescent Supply Current	V _{IN} =V _{CC} or GND I _{out} =0μA	5.5			2		20		40	μA	

AC Characteristics for HC: $t_r=t_f=6ns$ $C_L=50pF$

SYMBOL	PARAMETER	V _{CC} (V)	T _A =25°C			GD74HC04		GD54HC04		UNIT
			MIN.	TYP.	MAX.	MIN.	MAX.	MIN.	MAX.	
t _{PLH} / t _{PHL}	Propagation delay time nA nY	2.0		25	80		105		125	ns
		4.5		8	16		21		26	
		6.0		7	14		18		23	
t _{TLH} / t _{THL}	Output transition time	2.0		25	70		85		100	ns
		4.5		8	15		18		22	
		6.0		7	13		16		19	

AC Characteristics for HCT: $t_r=t_f=6ns$ $C_L=50pF$

SYMBOL	PARAMETER	V _{CC} (V)	T _A =25°C			GD74HCT04		GD54HCT04		UNIT
			MIN.	TYP.	MAX.	MIN.	MAX.	MIN.	MAX.	
t _{PLH} / t _{PHL}	Propagation delay time nA to nY	4.5		10	20		24		29	ns
t _{TLH} / t _{THL}	Output transition time	4.5		8	15		19		22	ns

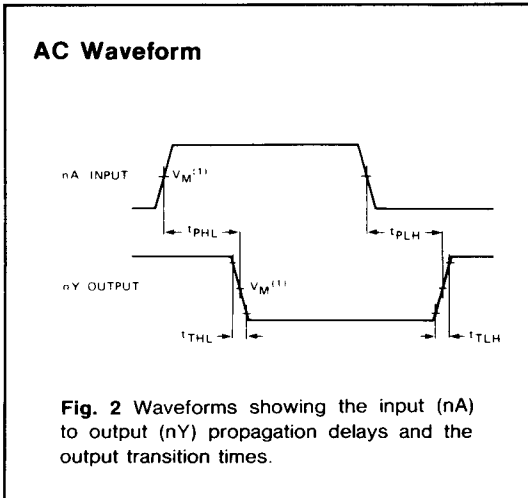

Note to AC waveform

- (1) HC : V_M=50%, V_L=GND to V_{CC}
- HCT: V_M=1.3V; V_L=GND to 3V.