

REVISION Y

DO NOT SCALE FROM THIS PRINT

END TO END	"L"
DV TO DV	950[24.131]
DV TO EM (-TX)	835[21.211]
DV TO EM (-SXX)	805[20.481]
EM (-TX) TO EM (-TX)	720[18.291]
EM (-TX) TO EM (-SXX)	691[17.551]
EM (-SXX) TO EM (-SXX)	662[16.811]
DV-N TO DV-N	840[21.341]
DV-N TO EM-N (-TX)	730[18.511]
DV-N TO EM-N (-SXX)	711[17.921]

FIG. 1
VERTICAL
(EQCD-040-XX.XX-STR-STR-1 SHOWN)

EQCD-XXX-XX.XX-XXX-XXX-X-X

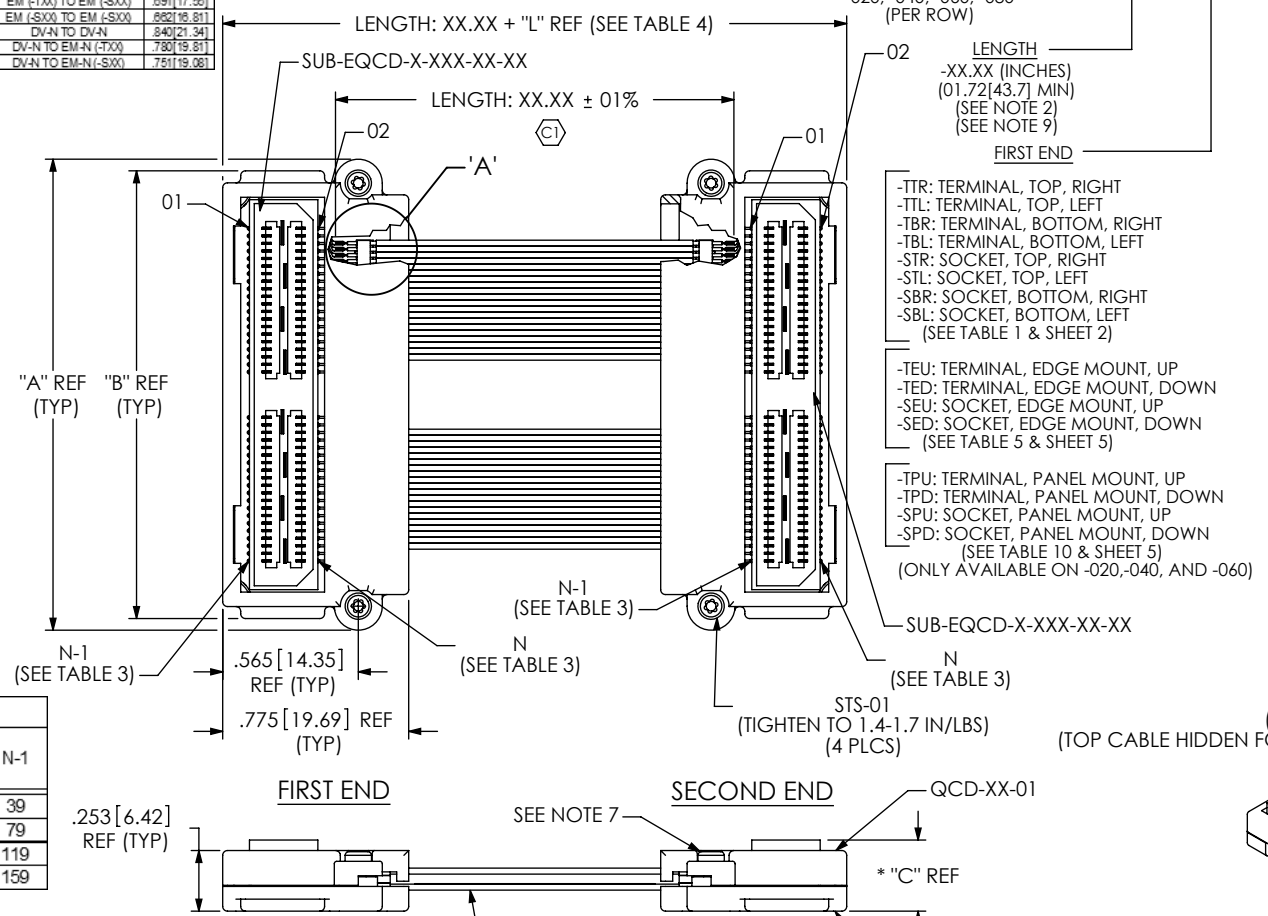

- END OPTION**
- F: SCREW OPTION FIRST END ONLY (NOT AVAILABLE WITH XPX OPTIONS)
 - S: SCREW OPTION SECOND END ONLY
 - B: SCREW OPTION BOTH ENDS (NOT AVAILABLE WITH XPX OPTIONS)
 - L: FIRST END RT1 OPTION (SEE NOTE 10 & 11)
 - R: SECOND END RT1 OPTION (SEE NOTE 10 & 11)
 - D: BOTH ENDS RT1 OPTION (SEE NOTE 10 & 11)
 - 1: FIRST END SCREW OPTION, SECOND END RT1 OPTION (SEE NOTE 10 & 11)
 - 2: FIRST END RT1 OPTION, SECOND END SCREW OPTION (SEE NOTE 10 & 11)
 - N: NO CAPS (LEAVE BLANK FOR STANDARD CAPS BOTH ENDS) (SEE FIG. 3, SHEET 5 FOR EDGE MOUNT END OPTIONS) (SEE FIG. 4, SHEET 5 FOR DOUBLE VERTICAL END OPTIONS) (RT1 OPTIONS NOT AVAILABLE WITH XPX OR XEX OPTIONS) (RT1 OPTIONS NOT AVAILABLE FOR 080 POSITION) (SEE SHEET 6 FOR RT1 AND NO CAP OPTIONS)

- WIRING OPTION**
- 1: PIN 1 TO PIN 1
 - 2: PIN 1 TO PIN 2
 - 3: PIN 1 TO PIN N-1
 - 4: PIN 1 TO PIN N (SEE TABLE 9, SHEET 7)
- SECOND END**
- TTR: TERMINAL, TOP, RIGHT
 - TTL: TERMINAL, TOP, LEFT
 - TBR: TERMINAL, BOTTOM, RIGHT
 - TBL: TERMINAL, BOTTOM, LEFT
 - STR: SOCKET, TOP, RIGHT
 - STL: SOCKET, TOP, LEFT
 - SBR: SOCKET, BOTTOM, RIGHT
 - SBL: SOCKET, BOTTOM, LEFT (SEE TABLE 1 & SHEET 3)
 - TEU: TERMINAL, EDGE MOUNT, UP
 - TED: TERMINAL, EDGE MOUNT, DOWN
 - SEU: SOCKET, EDGE MOUNT, UP
 - SED: SOCKET, EDGE MOUNT, DOWN (SEE TABLE 5 & SHEET 5)

- TERMINAL AND SOCKET OPTIONS**
- TR: TERMINAL, TOP, RIGHT
 - TL: TERMINAL, TOP, LEFT
 - BR: TERMINAL, BOTTOM, RIGHT
 - BL: TERMINAL, BOTTOM, LEFT
 - SR: SOCKET, TOP, RIGHT
 - SL: SOCKET, TOP, LEFT
 - SR: SOCKET, BOTTOM, RIGHT
 - SL: SOCKET, BOTTOM, LEFT (SEE TABLE 1 & SHEET 2)
 - TEU: TERMINAL, EDGE MOUNT, UP
 - TED: TERMINAL, EDGE MOUNT, DOWN
 - SEU: SOCKET, EDGE MOUNT, UP
 - SED: SOCKET, EDGE MOUNT, DOWN (SEE TABLE 5 & SHEET 5)
 - TPU: TERMINAL, PANEL MOUNT, UP
 - TPD: TERMINAL, PANEL MOUNT, DOWN
 - SPU: SOCKET, PANEL MOUNT, UP
 - SPD: SOCKET, PANEL MOUNT, DOWN (SEE TABLE 10 & SHEET 5) (ONLY AVAILABLE ON -020, -040, AND -060)

No. OF POSITIONS	N	N-1
-020	40	39
-040	80	79
-060	120	119
-080	160	159

- NOTES:**
- ⊙ REPRESENTS A CRITICAL DIMENSION.
 - SUB-TCF LENGTH IS EQUAL TO EQCD LENGTH.
 - ALL ASSEMBLIES TO BE 100% ELECTRICALLY TESTED FOR SHORTS AND OPENS.
 - ALL ASSEMBLIES TO BE 100% HI-POT TESTED AT 300V.
 - TOP SUB-TCF NOT SHOWN IN THIS VIEW FOR CLARITY; HDRL-11 TO BE CENTERED ON LOWER SUB-TCF AS SHOWN; HDRL-11 IS TO CONTAIN PART NUMBER, SHOP ORDER & DATE CODE.
 - PACKAGE ASSEMBLIES IN ANTI-STATIC & STATIC DISSIPATIVE BAGS.
 - TOP SURFACE OF SCREW TO BE FLUSH OR BELOW TOP SURFACE OF CAP.
 - PARTS TO BE PROCESSED PER SAMTEC ACCEPTABILITY REQUIREMENTS: HDR-PI-01 "CABLE ASSEMBLY WORKMANSHIP STANDARDS".
 - CABLE LENGTHS LONGER THAN 40.00 INCHES ARE NOT SUPPORTED BY S.I. TEST DATA.
 - RT1 OPTION IS NOT AVAILABLE WITH EDGEMOUNT OR PANEL MOUNT END OPTIONS.
 - RT1 OPTION IS NOT AVAILABLE WITH -080 POSITIONS.
 - ALL POSITIONS ARE TRANSMITTED AS SIGNALS ACROSS COAX CENTER CONDUCTORS. CONNECTOR GROUND BLADES ARE TIED TO THE COAX SHIELD. FOR MULTIPLE BANK ASSEMBLIES, EACH BANK IS GROUND INDEPENDENT OF THE OTHERS.

THIS PRODUCT MANUFACTURED WITH LEAD-FREE PROCESSING

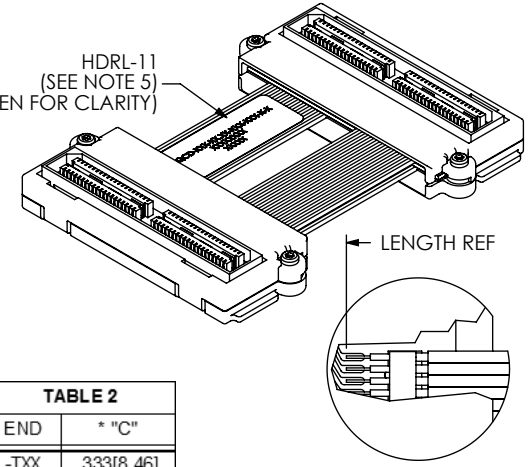

END	* "C"
-TX	.333[8.46]
-SXX	.296[7.52]

* -DV END OPTIONS ONLY

DETAIL 'A'
SCALE 2.5: 1

No. OF POSITIONS	"A"	"B"	QCD-XX-01	QCD-XX-02	QTY OF SUB-TCF	SUB-E QCD-X-XXX-XX-XX
-020	1.175[29.85]	1.078[27.38]	QCD-01-01	QCD-01-02	2	SUB-E QCD-X-020-XX-XX
-040	1.963[49.85]	1.866[47.40]	QCD-02-01	QCD-02-02	4	SUB-E QCD-X-040-XX-XX
-060	2.750[69.85]	2.653[67.39]	QCD-03-01	QCD-03-02	6	SUB-E QCD-X-060-XX-XX
-080	3.538[89.85]	3.441[87.39]	QCD-04-01	QCD-04-02	8	SUB-E QCD-X-080-XX-XX

UNLESS OTHERWISE SPECIFIED, DIMENSIONS ARE IN INCHES. TOLERANCES ARE:

DECIMALS ANGLES

.XX: ±.01 [.3]

.XXX: ±.005 [.13]

.XXXX: ±.0020 [.051]

2°

MATERIAL: DO NOT SCALE DRAWING SHEET SCALE: 1:0.8

PROPRIETARY NOTE
THIS DOCUMENT CONTAINS INFORMATION CONFIDENTIAL AND PROPRIETARY TO SAMTEC, INC. AND SHALL NOT BE REPRODUCED OR TRANSFERRED TO OTHER DOCUMENTS OR DISCLOSED TO OTHERS OR USED FOR ANY PURPOSE OTHER THAN THAT WHICH IT WAS OBTAINED WITHOUT THE EXPRESSED WRITTEN CONSENT OF SAMTEC, INC.

samtec

520 PARK EAST BLVD, NEW ALBANY, IN 47150
PHONE: 812-944-6733 FAX: 812-948-5047
e-Mail: info@SAMTEC.com code: 55322

DESCRIPTION:
0.8mm HIGH-SPEED COAX CABLE ASSEMBLY

DWG. NO.
EQCD-XXX-XX.XX-XXX-XXX-X-X

BY: KEVIN B 02/19/03 SHEET 1 OF 7

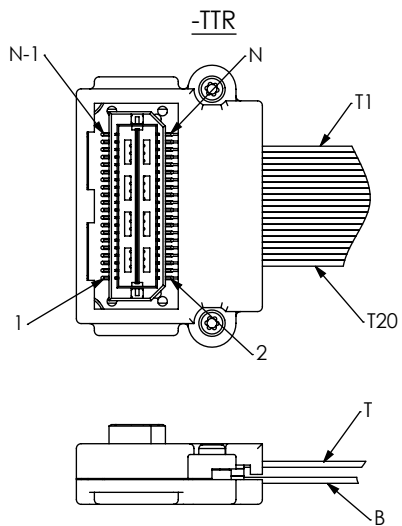

WIRING OPTION	FIRST END PIN #	SECOND END PIN #	WIRE NUMBER
1	1	1	B20
2	1	2	B20
3	1	N-1	B20
4	1	N	B20

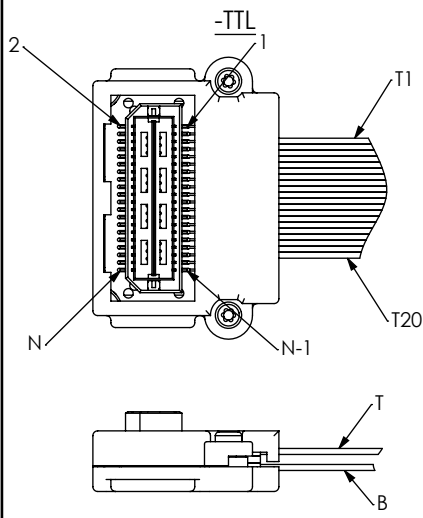

WIRING OPTION	FIRST END PIN #	SECOND END PIN #	WIRE NUMBER
1	1	1	T1
2	1	2	T1
3	1	N-1	T1
4	1	N	T1

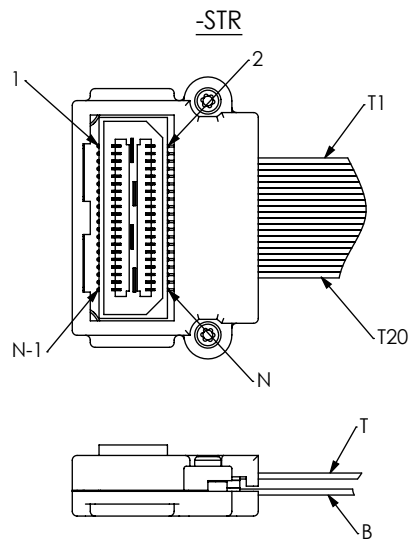

WIRING OPTION	FIRST END PIN #	SECOND END PIN #	WIRE NUMBER
1	1	1	B1
2	1	2	B1
3	1	N-1	B1
4	1	N	B1

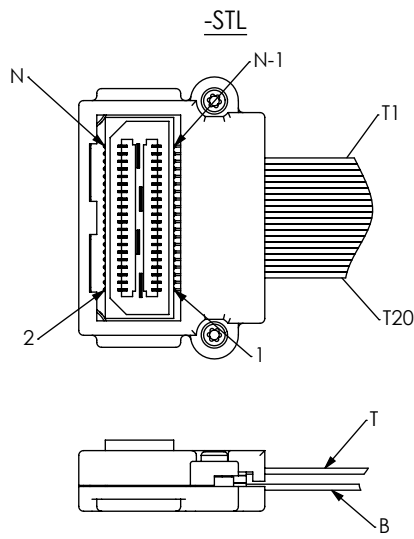

WIRING OPTION	FIRST END PIN #	SECOND END PIN #	WIRE NUMBER
1	1	1	T20
2	1	2	T20
3	1	N-1	T20
4	1	N	T20

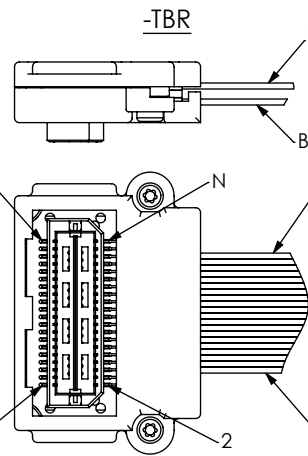

WIRING OPTION	FIRST END PIN #	SECOND END PIN #	WIRE NUMBER
1	1	1	T1
2	1	2	T1
3	1	N-1	T1
4	1	N	T1

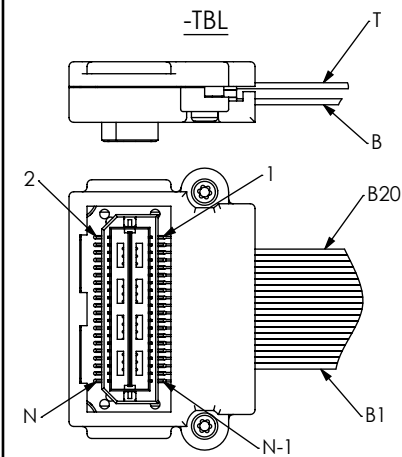

WIRING OPTION	FIRST END PIN #	SECOND END PIN #	WIRE NUMBER
1	1	1	B20
2	1	2	B20
3	1	N-1	B20
4	1	N	B20

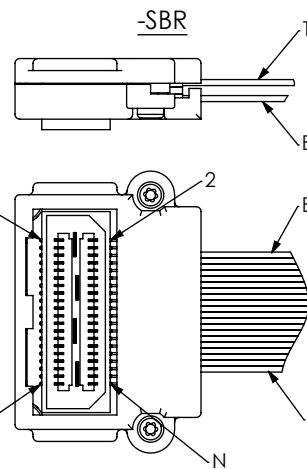

WIRING OPTION	FIRST END PIN #	SECOND END PIN #	WIRE NUMBER
1	1	1	T20
2	1	2	T20
3	1	N-1	T20
4	1	N	T20

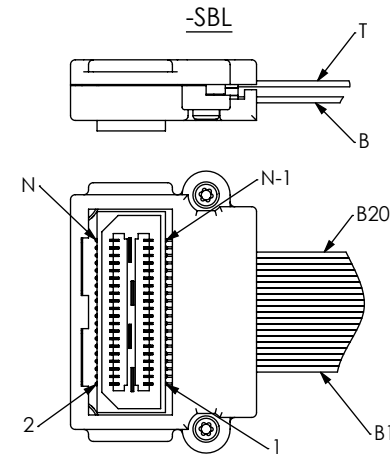

WIRING OPTION	FIRST END PIN #	SECOND END PIN #	WIRE NUMBER
1	1	1	B1
2	1	2	B1
3	1	N-1	B1
4	1	N	B1

PROPRIETARY NOTE
 THIS DOCUMENT CONTAINS INFORMATION CONFIDENTIAL AND PROPRIETARY TO SAMTEC, INC. AND SHALL NOT BE REPRODUCED OR TRANSFERRED TO OTHER DOCUMENTS OR DISCLOSED TO OTHERS OR USED FOR ANY PURPOSE OTHER THAN THAT WHICH IT WAS OBTAINED WITHOUT THE EXPRESSED WRITTEN CONSENT OF SAMTEC, INC.

DO NOT SCALE DRAWING

SHEET SCALE: 1:25:1



520 PARK EAST BLVD, NEW ALBANY, IN 47150
 PHONE: 812-944-6733 FAX: 812-948-5047
 e-Mail: info@SAMTEC.com code: 55322

DESCRIPTION:
 0.8mm HIGH-SPEED COAX CABLE ASSEMBLY

DWG. NO.
 EQCD-XXX-XX.XX-XXX-XXX-X-X

BY: KEVIN B 02/19/03 SHEET 2 OF 7

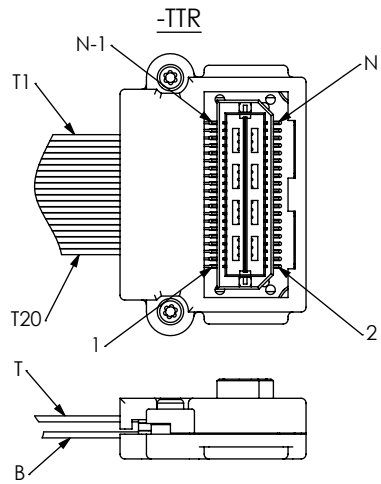

WIRING OPTION	FIRST END PIN #	SECOND END PIN #
1	1	1
2	1	2
3	1	N-1
4	1	N

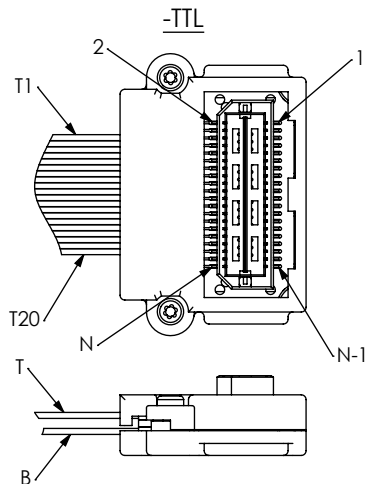

WIRING OPTION	FIRST END PIN #	SECOND END PIN #
1	1	1
2	1	2
3	1	N-1
4	1	N

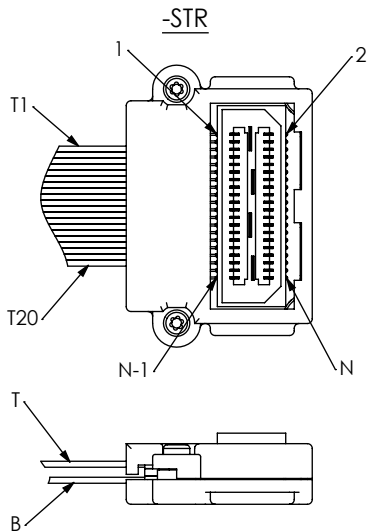

WIRING OPTION	FIRST END PIN #	SECOND END PIN #
1	1	1
2	1	2
3	1	N-1
4	1	N

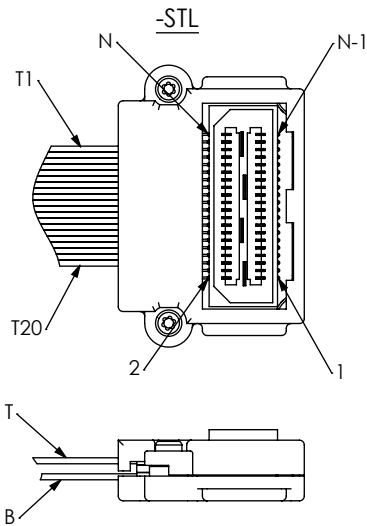

WIRING OPTION	FIRST END PIN #	SECOND END PIN #
1	1	1
2	1	2
3	1	N-1
4	1	N

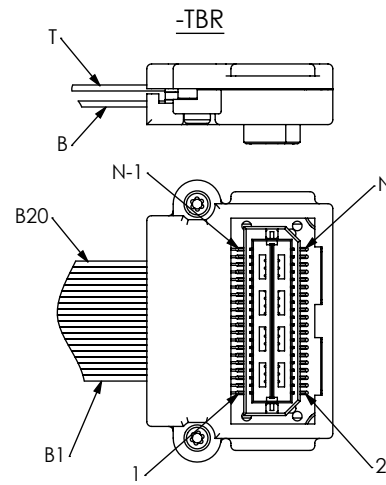

WIRING OPTION	FIRST END PIN #	SECOND END PIN #
1	1	1
2	1	2
3	1	N-1
4	1	N

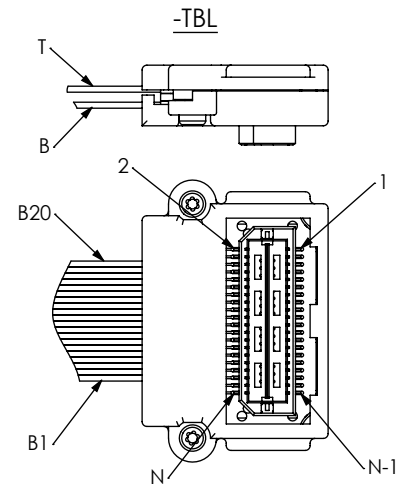

WIRING OPTION	FIRST END PIN #	SECOND END PIN #
1	1	1
2	1	2
3	1	N-1
4	1	N

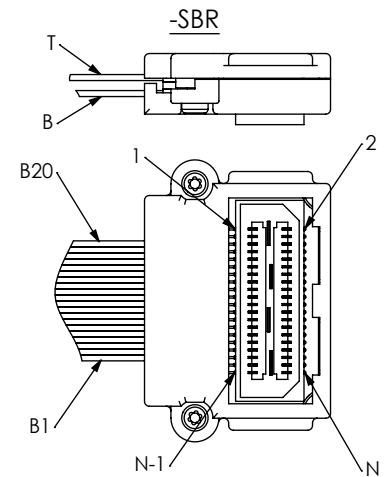

WIRING OPTION	FIRST END PIN #	SECOND END PIN #
1	1	1
2	1	2
3	1	N-1
4	1	N

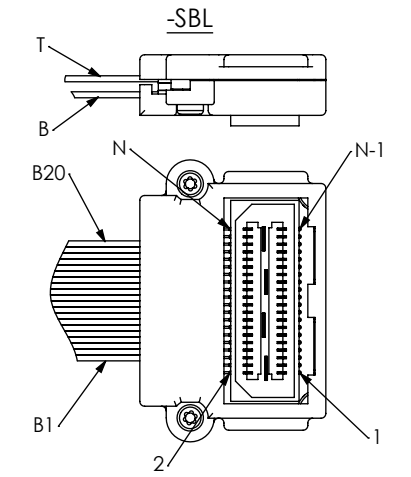

WIRING OPTION	FIRST END PIN #	SECOND END PIN #
1	1	1
2	1	2
3	1	N-1
4	1	N

PROPRIETARY NOTE
 THIS DOCUMENT CONTAINS INFORMATION CONFIDENTIAL AND PROPRIETARY TO SAMTEC, INC. AND SHALL NOT BE REPRODUCED OR TRANSFERRED TO OTHER DOCUMENTS OR DISCLOSED TO OTHERS OR USED FOR ANY PURPOSE OTHER THAN THAT WHICH IT WAS OBTAINED WITHOUT THE EXPRESSED WRITTEN CONSENT OF SAMTEC, INC.

DO NOT SCALE DRAWING

SHEET SCALE: 1:25:1



520 PARK EAST BLVD. NEW ALBANY, IN 47150
 PHONE: 812-944-6733 FAX: 812-948-5047
 e-Mail: info@SAMTEC.com code: 55322

DESCRIPTION:
 0.8mm HIGH-SPEED COAX CABLE ASSEMBLY

DWG. NO.
 EQCD-XXX-XX.XX-XXX-XXX-X-X

BY: KEVIN B 02/19/03 SHEET 3 OF 7

REVISION Y

FIRST END - EDGE MOUNT (SEE TABLE 9, SHEET 7)

-TEU

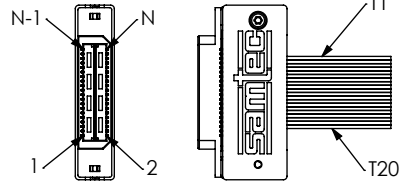

WIRING OPTION	FIRST END PIN #	SECOND END PIN #	WIRE #
1	1	1	T1
2	1	2	T1
3	1	N-1	T1
4	1	N	T1

-TED

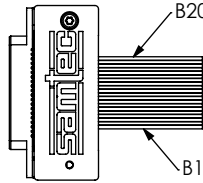
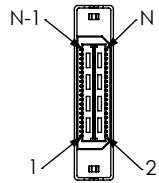
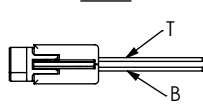

WIRING OPTION	FIRST END PIN #	SECOND END PIN #	WIRE #
1	1	1	B20
2	1	2	B20
3	1	N-1	B20
4	1	N	B20

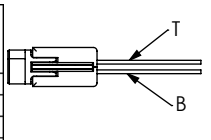

WIRING OPTION	FIRST END PIN #	SECOND END PIN #	WIRE #
1	1	1	T20
2	1	2	T20
3	1	N-1	T20
4	1	N	T20

-SED

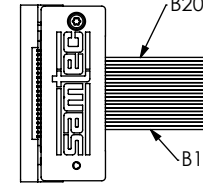
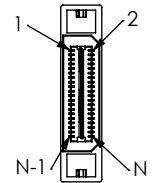
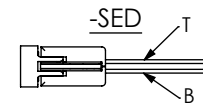

WIRING OPTION	FIRST END PIN #	SECOND END PIN #	WIRE #
1	1	1	B1
2	1	2	B1
3	1	N-1	B1
4	1	N	B1

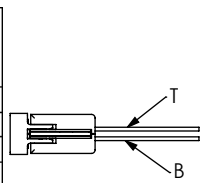

-SEU

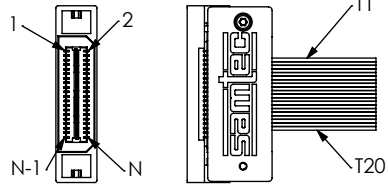

FIRST END - PANEL MOUNT (SEE TABLE 9, SHEET 6)

-SPU

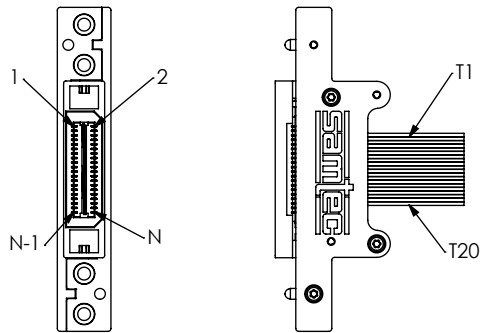

WIRING OPTION	FIRST END PIN #	SECOND END PIN #	WIRE #
1	1	1	B1
2	1	2	B1
3	1	N-1	B1
4	1	N	B1

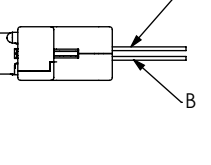

-SPD

WIRING OPTION	FIRST END PIN #	SECOND END PIN #	WIRE #
1	1	1	T20
2	1	2	T20
3	1	N-1	T20
4	1	N	T20

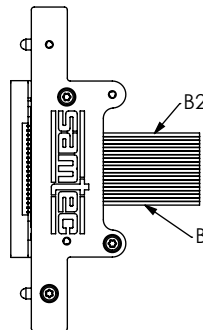
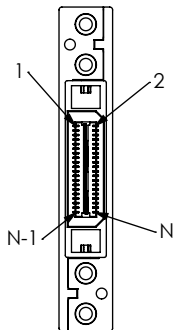
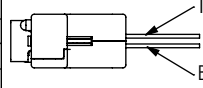

SECOND END - EDGE MOUNT (SEE TABLE 9, SHEET 7)

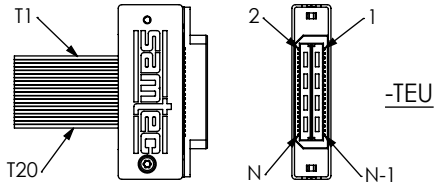

WIRING OPTION	FIRST END PIN #	SECOND END PIN #
1	1	1
2	1	2
3	1	N-1
4	1	N

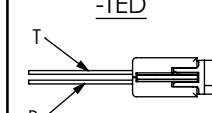

WIRING OPTION	FIRST END PIN #	SECOND END PIN #
1	1	1
2	1	2
3	1	N-1
4	1	N

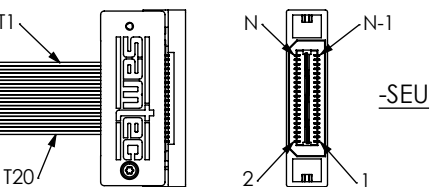
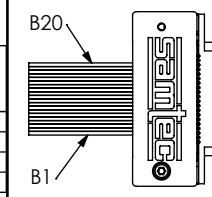

WIRING OPTION	FIRST END PIN #	SECOND END PIN #
1	1	1
2	1	2
3	1	N-1
4	1	N

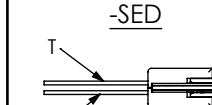

WIRING OPTION	FIRST END PIN #	SECOND END PIN #
1	1	1
2	1	2
3	1	N-1
4	1	N

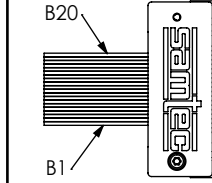

FIRST END - PANEL MOUNT (SEE TABLE 9, SHEET 6)

-TPU

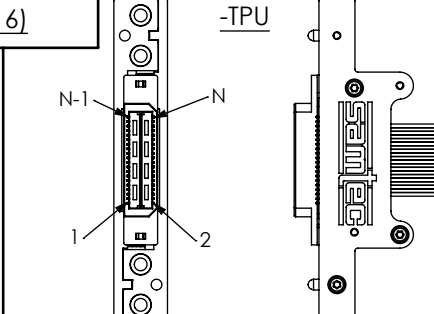

WIRING OPTION	FIRST END PIN #	SECOND END PIN #	WIRE #
1	1	1	B20
2	1	2	B20
3	1	N-1	B20
4	1	N	B20

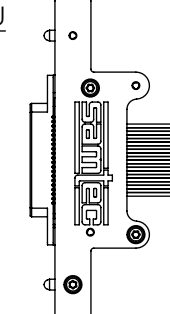

WIRING OPTION	FIRST END PIN #	SECOND END PIN #	WIRE #
1	1	1	T1
2	1	2	T1
3	1	N-1	T1
4	1	N	T1

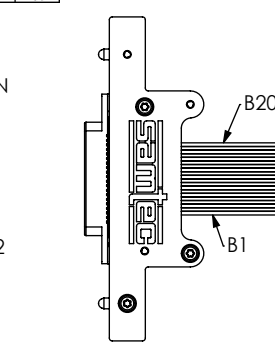
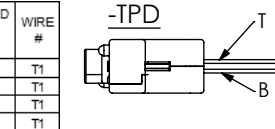
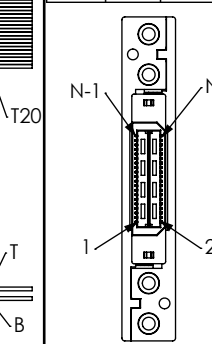

PROPRIETARY NOTE

THIS DOCUMENT CONTAINS INFORMATION CONFIDENTIAL AND PROPRIETARY TO SAMTEC, INC. AND SHALL NOT BE REPRODUCED OR TRANSFERRED TO OTHER DOCUMENTS OR DISCLOSED TO OTHERS OR USED FOR ANY PURPOSE OTHER THAN THAT WHICH IT WAS OBTAINED WITHOUT THE EXPRESSED WRITTEN CONSENT OF SAMTEC, INC.

DO NOT SCALE DRAWING

SHEET SCALE: 1:1



520 PARK EAST BLVD, NEW ALBANY, IN 47150
PHONE: 812-944-6733 FAX: 812-948-5047
e-Mail: info@SAMTEC.com code: 53322

DESCRIPTION:
0.8mm HIGH-SPEED COAX CABLE ASSEMBLY

DWG. NO.
EQCD-XXX-XX.XX-XXX-XXX-X-X

BY: KEVIN B 02/19/03 SHEET 4 OF 7

FIG 3
EDGE MOUNT (WITH CAPTIVE PANEL SCREWS)
(EQCD-020-XX.XX-SEU-XXX-1-F SHOWN)
(SAME AS FIG. 2, UNLESS OTHERWISE STATED)

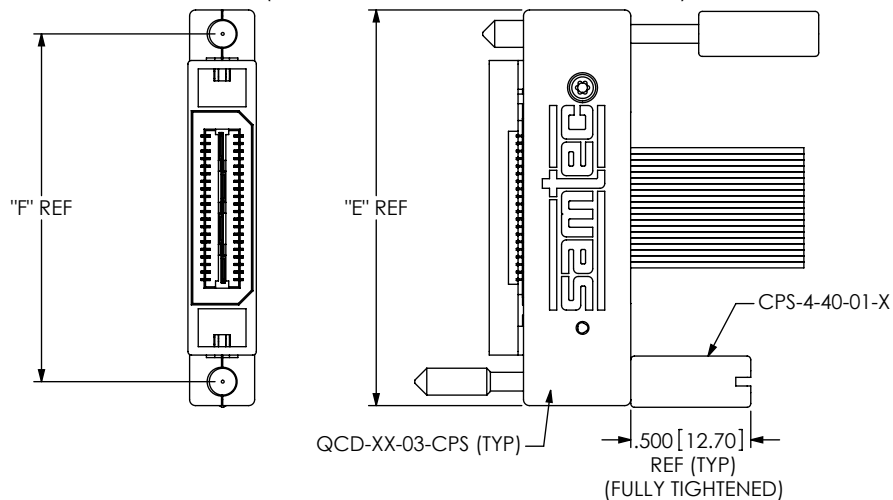

TABLE 6

No. OF POSITIONS	"E"	"F"	QCD-XX-03-CPS
-020	1.649[41.87]	1.449[36.80]	QCD-01-03-CPS
-040	2.436[61.87]	2.237[56.80]	QCD-02-03-CPS
-060	3.224[81.87]	3.024[76.80]	QCD-03-03-CPS
-080	4.011[101.87]	3.812[96.80]	QCD-04-03-CPS

FIG 2
EDGE MOUNT (NO CAPTIVE PANEL SCREWS)
(EQCD-020-XX.XX-TEU-STR-X SHOWN)
(SAME AS FIG. 1, UNLESS OTHERWISE STATED)

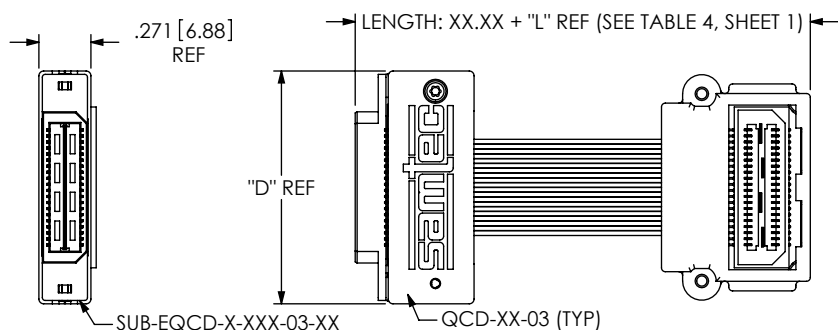

TABLE 5

No. OF POSITIONS	"D"	QCD-XXX-03	SUB-EQCD-X-XXX-XX-XX
-020	1.213[30.80]	QCD-01-03	SUB-EQCD-X-020-03-XX
-040	2.000[50.80]	QCD-02-03	SUB-EQCD-X-040-03-XX
-060	2.788[70.80]	QCD-03-03	SUB-EQCD-X-060-03-XX
-080	3.575[90.80]	QCD-04-03	SUB-EQCD-X-080-03-XX

FIG 4
DOUBLE VERTICAL (WITH SCREW DOWN OPTION)
(EQCD-020-XX.XX-TTR-XXX-1-F SHOWN)
(SAME AS FIG. 1, UNLESS OTHERWISE STATED)

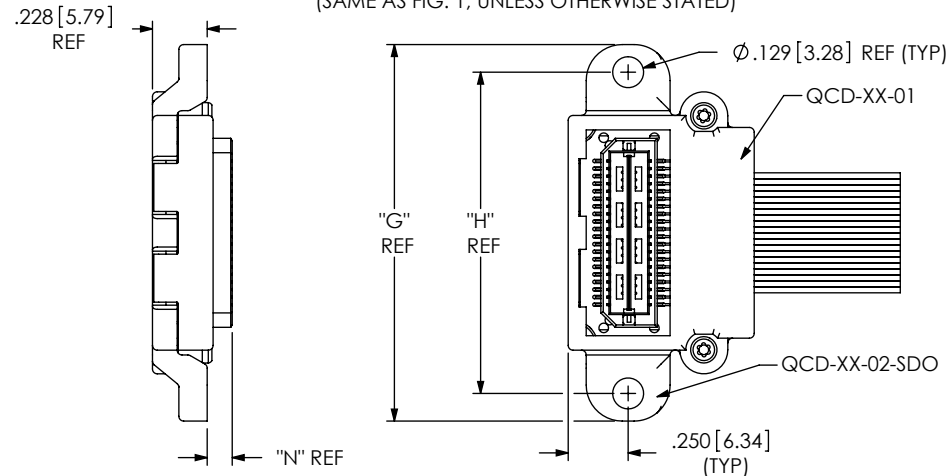

TABLE 8

END	"N"
-TXX	.104[2.65]
-SXX	.068[1.73]

TABLE 7

No. OF POSITIONS	"G"	"H"	QCD-XX-02-SDO
-020	1.579[40.10]	1.339[34.00]	QCD-01-02-SDO
-040	2.366[60.10]	2.126[54.00]	QCD-02-02-SDO
-060	3.154[80.10]	2.913[74.00]	QCD-03-02-SDO
-080	3.941[100.10]	3.701[94.00]	QCD-04-02-SDO

FIG 5
PANEL MOUNT (BUCK HEAD SCREW INSERTS)
(EQCD-020-XX.XX-TPU-XXX-X SHOWN)
(SAME AS FIG. 2, UNLESS OTHERWISE STATED)

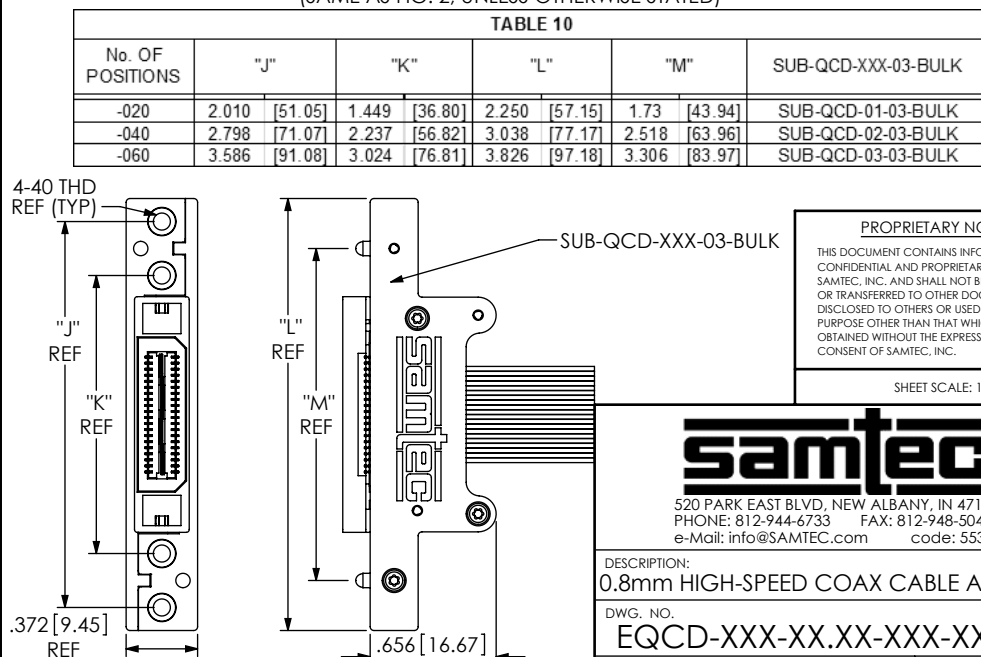

TABLE 10

No. OF POSITIONS	"J"	"K"	"L"	"M"	SUB-QCD-XXX-03-BULK
-020	2.010 [51.05]	1.449 [36.80]	2.250 [57.15]	1.73 [43.94]	SUB-QCD-01-03-BULK
-040	2.798 [71.07]	2.237 [56.82]	3.038 [77.17]	2.518 [63.96]	SUB-QCD-02-03-BULK
-060	3.586 [91.08]	3.024 [76.81]	3.826 [97.18]	3.306 [83.97]	SUB-QCD-03-03-BULK

PROPRIETARY NOTE

THIS DOCUMENT CONTAINS INFORMATION CONFIDENTIAL AND PROPRIETARY TO SAMTEC, INC. AND SHALL NOT BE REPRODUCED OR TRANSFERRED TO OTHER DOCUMENTS OR DISCLOSED TO OTHERS OR USED FOR ANY PURPOSE OTHER THAN THAT WHICH IT WAS OBTAINED WITHOUT THE EXPRESSED WRITTEN CONSENT OF SAMTEC, INC.

SHEET SCALE: 1.25:1



520 PARK EAST BLVD, NEW ALBANY, IN 47150
PHONE: 812-944-6733 FAX: 812-948-5047
e-Mail: info@SAMTEC.com code: 55322

DESCRIPTION:
0.8mm HIGH-SPEED COAX CABLE ASSEMBLY

DWG. NO.
EQCD-XXX-XX.XX-XXX-XXX-X-X

BY: KEVIN B 02/19/03 SHEET 5 OF 7

FIG 6
(EQCD-020-XX.X-STL-TTR-1-D SHOWN)
(SAME AS FIG 1, UNLESS OTHERWISE STATED)

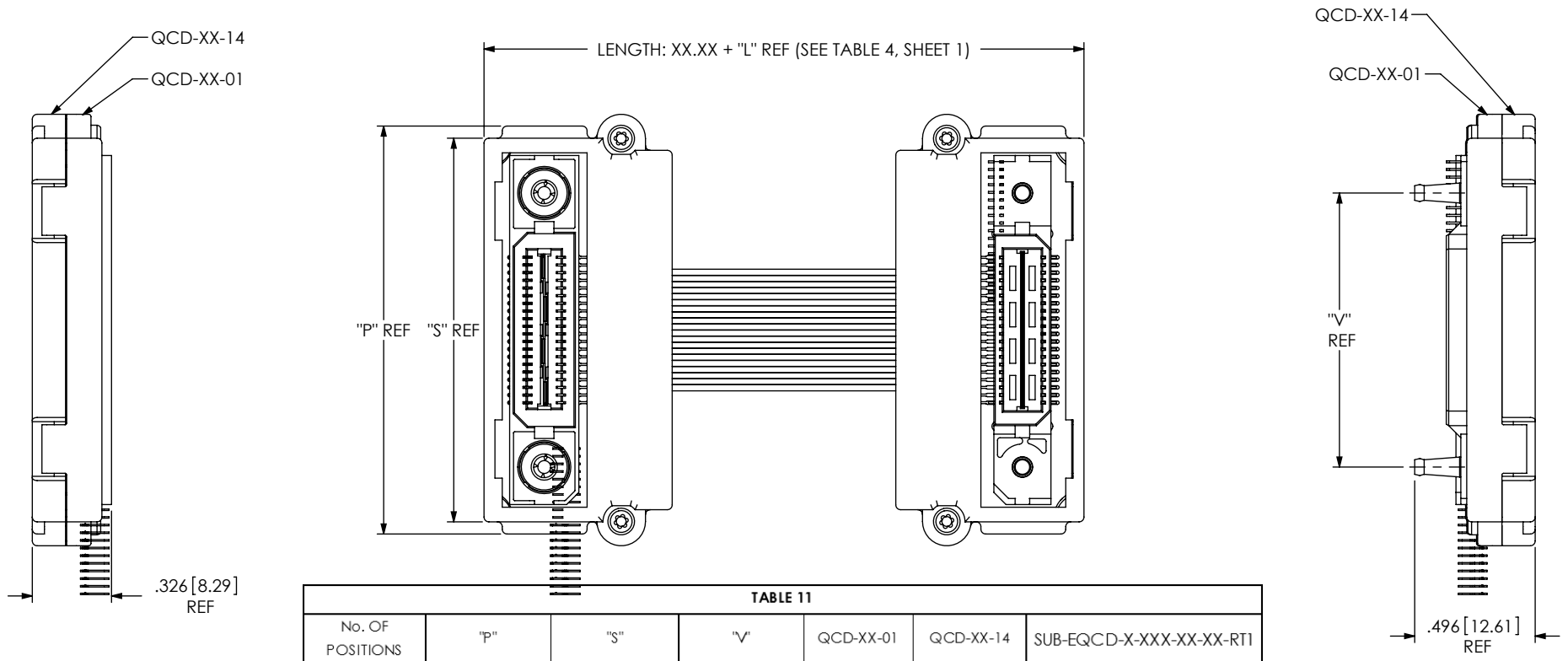

TABLE 11

No. OF POSITIONS	"p"	"s"	"v"	QCD-XX-01	QCD-XX-14	SUB-EQCD-X-XXX-XX-XX-RT1
-020	1.777 [45.14]	1.680 [42.67]	1.129 [28.66]	QCD-07-01	QCD-01-14	SUB-EQCD-X-020-XX-XX-RT1
-040	2.565 [65.15]	2.468 [62.69]	1.916 [48.67]	QCD-08-01	QCD-02-14	SUB-EQCD-X-040-XX-XX-RT1
-060	3.352 [85.14]	3.255 [82.68]	2.704 [68.67]	QCD-09-01	QCD-03-14	SUB-EQCD-X-060-XX-XX-RT1
-080	4.140 [105.16]	4.043 [102.69]	3.491 [88.67]	QCD-10-01	QCD-04-14	SUB-EQCD-X-080-XX-XX-RT1

FIG 7
(EQCD-XXX-XX.X-XXX-XXX-X-N)
(SAME AS FIG 1, UNLESS OTHERWISE STATED)

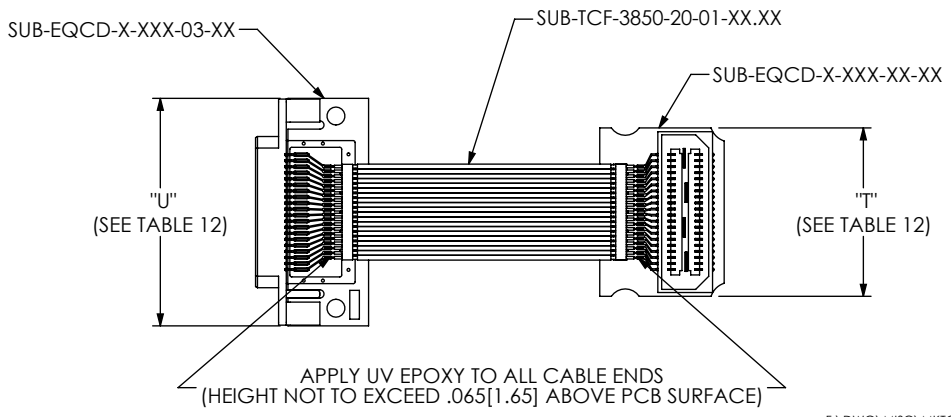

TABLE 12

No. OF POSITIONS	"T"	"U"
-20	0.877 [22.28]	1.185 [30.10]
-40	1.665 [42.29]	1.973 [50.11]
-60	2.453 [62.31]	2.760 [70.10]
-80	3.240 [82.30]	3.548 [90.12]

PROPRIETARY NOTE
THIS DOCUMENT CONTAINS INFORMATION CONFIDENTIAL AND PROPRIETARY TO SAMTEC, INC. AND SHALL NOT BE REPRODUCED OR TRANSFERRED TO OTHER DOCUMENTS OR DISCLOSED TO OTHERS OR USED FOR ANY PURPOSE OTHER THAN THAT WHICH IT WAS OBTAINED WITHOUT THE EXPRESSED WRITTEN CONSENT OF SAMTEC, INC.

SHEET SCALE: 1.5:1

520 PARK EAST BLVD, NEW ALBANY, IN 47150
PHONE: 812-944-6733 FAX: 812-948-5047
e-Mail: info@SAMTEC.com code: 55322

DESCRIPTION:
0.8mm HIGH-SPEED COAX CABLE ASSEMBLY

DWG. NO.
EQCD-XXX-XX.XX-XXX-XXX-X-X

BY: KEVIN B 02/19/03 SHEET 6 OF 7

FIRST END OPTION	FIRST END SUB-EQCD-X-XXX-XX-01	WIRING OPTION	FIRST END PIN #	SECOND END PIN #	WIRE #	TABLE 9 SECOND END OPTION (SUB-EQCD-X-XXX-XX-XX)												
						-TTR	-TTL	-TBR	-TBL	-STR	-STL	-SBR	-SBL	-TEU	-TED	-SEU	-SED	
-TTR	-T-XXX-01-01	1	1	1	B20	-T-XXX-02-02	N/A	N/A	-T-XXX-01-02	N/A	-S-XXX-01-01	-S-XXX-02-01	N/A	N/A	-T-XXX-03-02	-S-XXX-03-01	N/A	
		2	1	2	B20	-T-XXX-02-01	N/A	N/A	-T-XXX-01-01	N/A	-S-XXX-01-02	-S-XXX-02-02	N/A	N/A	-T-XXX-03-01	-S-XXX-03-02	N/A	
		3	1	N-1	B20	N/A	-T-XXX-01-01	-T-XXX-02-01	N/A	-S-XXX-02-02	N/A	N/A	-S-XXX-01-02	-T-XXX-03-01	N/A	N/A	-S-XXX-03-02	-S-XXX-03-01
		4	1	N	B20	N/A	-T-XXX-01-02	-T-XXX-02-02	N/A	-S-XXX-02-01	N/A	N/A	-S-XXX-01-01	-T-XXX-03-02	N/A	N/A	-S-XXX-03-01	-S-XXX-03-02
-TTL	-T-XXX-02-01	1	1	1	T1	N/A	-T-XXX-01-01	-T-XXX-02-01	N/A	-S-XXX-02-01	N/A	N/A	-S-XXX-01-02	-T-XXX-03-01	N/A	N/A	-S-XXX-03-02	
		2	1	2	T1	N/A	-T-XXX-01-01	-T-XXX-02-01	N/A	-S-XXX-02-02	N/A	N/A	-S-XXX-01-02	-T-XXX-03-01	N/A	N/A	-S-XXX-03-02	
		3	1	N-1	T1	-T-XXX-02-01	N/A	N/A	-T-XXX-01-01	N/A	-S-XXX-01-02	-S-XXX-02-02	N/A	N/A	-T-XXX-03-01	-S-XXX-03-02	N/A	
		4	1	N	T1	-T-XXX-02-02	N/A	N/A	-T-XXX-01-02	N/A	-S-XXX-01-01	-S-XXX-02-01	N/A	N/A	-T-XXX-03-02	-S-XXX-03-01	N/A	
-TBR	-T-XXX-01-01	1	1	1	T1	N/A	-T-XXX-01-02	-T-XXX-02-02	N/A	-S-XXX-02-01	N/A	N/A	-S-XXX-01-01	-T-XXX-03-02	N/A	N/A	-S-XXX-03-01	
		2	1	2	T1	N/A	-T-XXX-01-01	-T-XXX-02-01	N/A	-S-XXX-02-02	N/A	N/A	-S-XXX-01-02	-T-XXX-03-01	N/A	N/A	-S-XXX-03-02	
		3	1	N-1	T1	-T-XXX-02-01	N/A	N/A	-T-XXX-01-01	N/A	-S-XXX-01-02	-S-XXX-02-02	N/A	N/A	-T-XXX-03-01	-S-XXX-03-02	N/A	
		4	1	N	T1	-T-XXX-02-02	N/A	N/A	-T-XXX-01-02	N/A	-S-XXX-01-01	-S-XXX-02-01	N/A	N/A	-T-XXX-03-02	-S-XXX-03-01	N/A	
-TBL	-T-XXX-02-01	1	1	1	B20	-T-XXX-02-02	N/A	N/A	-T-XXX-01-02	N/A	-S-XXX-01-01	-S-XXX-02-01	N/A	N/A	-T-XXX-03-02	-S-XXX-03-01	N/A	
		2	1	2	B20	-T-XXX-02-01	N/A	N/A	-T-XXX-01-01	N/A	-S-XXX-01-02	-S-XXX-02-02	N/A	N/A	-T-XXX-03-01	-S-XXX-03-02	N/A	
		3	1	N-1	B20	N/A	-T-XXX-01-01	-T-XXX-02-01	N/A	-S-XXX-02-02	N/A	N/A	-S-XXX-01-02	-T-XXX-03-01	N/A	N/A	-S-XXX-03-02	
		4	1	N	B20	N/A	-T-XXX-01-02	-T-XXX-02-02	N/A	-S-XXX-02-01	N/A	N/A	-S-XXX-01-01	-T-XXX-03-02	N/A	N/A	-S-XXX-03-01	
-STR	-S-XXX-01-01	1	1	1	B1	N/A	-T-XXX-01-01	-T-XXX-02-01	N/A	-S-XXX-02-02	N/A	N/A	-S-XXX-01-02	-T-XXX-03-01	N/A	N/A	-S-XXX-03-02	
		2	1	2	B1	N/A	-T-XXX-01-02	-T-XXX-02-02	N/A	-S-XXX-02-01	N/A	N/A	-S-XXX-01-01	-T-XXX-03-02	N/A	N/A	-S-XXX-03-01	
		3	1	N-1	B1	-T-XXX-02-02	N/A	N/A	-T-XXX-01-02	N/A	-S-XXX-01-01	-S-XXX-02-01	N/A	N/A	-T-XXX-03-02	-S-XXX-03-01	N/A	
		4	1	N	B1	-T-XXX-02-01	N/A	N/A	-T-XXX-01-01	N/A	-S-XXX-01-02	-S-XXX-02-02	N/A	N/A	-T-XXX-03-01	-S-XXX-03-02	N/A	
-STL	-S-XXX-02-01	1	1	1	T20	-T-XXX-02-01	N/A	N/A	-T-XXX-01-01	N/A	-S-XXX-01-02	-S-XXX-02-02	N/A	N/A	-T-XXX-03-01	-S-XXX-03-02	N/A	
		2	1	2	T20	-T-XXX-02-02	N/A	N/A	-T-XXX-01-02	N/A	-S-XXX-01-01	-S-XXX-02-01	N/A	N/A	-T-XXX-03-02	-S-XXX-03-01	N/A	
		3	1	N-1	T20	N/A	-T-XXX-01-02	-T-XXX-02-02	N/A	-S-XXX-02-01	N/A	N/A	-S-XXX-01-01	-T-XXX-03-02	N/A	N/A	-S-XXX-03-01	
		4	1	N	T20	N/A	-T-XXX-01-01	-T-XXX-02-01	N/A	-S-XXX-02-02	N/A	N/A	-S-XXX-01-02	-T-XXX-03-01	N/A	N/A	-S-XXX-03-02	
-SBR	-S-XXX-01-01	1	1	1	T20	-T-XXX-02-01	N/A	N/A	-T-XXX-01-01	N/A	-S-XXX-01-02	-S-XXX-02-02	N/A	N/A	-T-XXX-03-01	-S-XXX-03-02	N/A	
		2	1	2	T20	-T-XXX-02-02	N/A	N/A	-T-XXX-01-02	N/A	-S-XXX-01-01	-S-XXX-02-01	N/A	N/A	-T-XXX-03-02	-S-XXX-03-01	N/A	
		3	1	N-1	T20	N/A	-T-XXX-01-02	-T-XXX-02-02	N/A	-S-XXX-02-01	N/A	N/A	-S-XXX-01-01	-T-XXX-03-02	N/A	N/A	-S-XXX-03-01	
		4	1	N	T20	N/A	-T-XXX-01-01	-T-XXX-02-01	N/A	-S-XXX-02-02	N/A	N/A	-S-XXX-01-02	-T-XXX-03-01	N/A	N/A	-S-XXX-03-02	
-SBL	-S-XXX-02-01	1	1	1	B1	N/A	-T-XXX-01-01	-T-XXX-02-01	N/A	-S-XXX-02-02	N/A	N/A	-S-XXX-01-02	-T-XXX-03-01	N/A	N/A	-S-XXX-03-02	
		2	1	2	B1	N/A	-T-XXX-01-02	-T-XXX-02-02	N/A	-S-XXX-02-01	N/A	N/A	-S-XXX-01-01	-T-XXX-03-02	N/A	N/A	-S-XXX-03-01	
		3	1	N-1	B1	-T-XXX-02-02	N/A	N/A	-T-XXX-01-02	N/A	-S-XXX-01-01	-S-XXX-02-01	N/A	N/A	-T-XXX-03-02	-S-XXX-03-01	N/A	
		4	1	N	B1	-T-XXX-02-01	N/A	N/A	-T-XXX-01-01	N/A	-S-XXX-01-02	-S-XXX-02-02	N/A	N/A	-T-XXX-03-01	-S-XXX-03-02	N/A	
-TEU	-T-XXX-03-01	1	1	1	B20	-T-XXX-02-02	N/A	N/A	-T-XXX-01-02	N/A	-S-XXX-01-01	-S-XXX-02-01	N/A	N/A	-T-XXX-03-02	-S-XXX-03-01	N/A	
		2	1	2	B20	-T-XXX-02-01	N/A	N/A	-T-XXX-01-01	N/A	-S-XXX-01-02	-S-XXX-02-02	N/A	N/A	-T-XXX-03-01	-S-XXX-03-02	N/A	
		3	1	N-1	B20	N/A	-T-XXX-01-01	-T-XXX-02-01	N/A	-S-XXX-02-02	N/A	N/A	-S-XXX-01-02	-T-XXX-03-01	N/A	N/A	-S-XXX-03-02	
		4	1	N	B20	N/A	-T-XXX-01-02	-T-XXX-02-02	N/A	-S-XXX-02-01	N/A	N/A	-S-XXX-01-01	-T-XXX-03-02	N/A	N/A	-S-XXX-03-01	
-TED	-T-XXX-03-01	1	1	1	T1	N/A	-T-XXX-01-02	-T-XXX-02-02	N/A	-S-XXX-02-01	N/A	N/A	-S-XXX-01-01	-T-XXX-03-02	N/A	N/A	-S-XXX-03-01	
		2	1	2	T1	N/A	-T-XXX-01-01	-T-XXX-02-01	N/A	-S-XXX-02-02	N/A	N/A	-S-XXX-01-02	-T-XXX-03-01	N/A	N/A	-S-XXX-03-02	
		3	1	N-1	T1	-T-XXX-02-01	N/A	N/A	-T-XXX-01-01	N/A	-S-XXX-01-02	-S-XXX-02-02	N/A	N/A	-T-XXX-03-01	-S-XXX-03-02	N/A	
		4	1	N	T1	-T-XXX-02-02	N/A	N/A	-T-XXX-01-02	N/A	-S-XXX-01-01	-S-XXX-02-01	N/A	N/A	-T-XXX-03-02	-S-XXX-03-01	N/A	
-SEU	-S-XXX-03-01	1	1	1	B1	N/A	-T-XXX-01-01	-T-XXX-02-01	N/A	-S-XXX-02-02	N/A	N/A	-S-XXX-01-02	-T-XXX-03-01	N/A	N/A	-S-XXX-03-02	
		2	1	2	B1	N/A	-T-XXX-01-02	-T-XXX-02-02	N/A	-S-XXX-02-01	N/A	N/A	-S-XXX-01-01	-T-XXX-03-02	N/A	N/A	-S-XXX-03-01	
		3	1	N-1	B1	-T-XXX-02-02	N/A	N/A	-T-XXX-01-02	N/A	-S-XXX-01-01	-S-XXX-02-01	N/A	N/A	-T-XXX-03-02	-S-XXX-03-01	N/A	
		4	1	N	B1	-T-XXX-02-01	N/A	N/A	-T-XXX-01-01	N/A	-S-XXX-01-02	-S-XXX-02-02	N/A	N/A	-T-XXX-03-01	-S-XXX-03-02	N/A	
-SED	-S-XXX-03-01	1	1	1	T20	-T-XXX-02-01	N/A	N/A	-T-XXX-01-01	N/A	-S-XXX-01-02	-S-XXX-02-02	N/A	N/A	-T-XXX-03-01	-S-XXX-03-02	N/A	
		2	1	2	T20	-T-XXX-02-02	N/A	N/A	-T-XXX-01-02	N/A	-S-XXX-01-01	-S-XXX-02-01	N/A	N/A	-T-XXX-03-02	-S-XXX-03-01	N/A	
		3	1	N-1	T20	N/A	-T-XXX-01-02	-T-XXX-02-02	N/A	-S-XXX-02-01	N/A	N/A	-S-XXX-01-01	-T-XXX-03-02	N/A	N/A	-S-XXX-03-01	
		4	1	N	T20	N/A	-T-XXX-01-01	-T-XXX-02-01	N/A	-S-XXX-02-02	N/A	N/A	-S-XXX-01-02	-T-XXX-03-01	N/A	N/A	-S-XXX-03-02	
-TPU	-T-XXX-03-01	1	1	1	B20	-T-XXX-02-02	N/A	N/A	-T-XXX-01-02	N/A	-S-XXX-01-01	-S-XXX-02-01	N/A	N/A	-T-XXX-03-02	-S-XXX-03-01	N/A	
		2	1	2	B20	-T-XXX-02-01	N/A	N/A	-T-XXX-01-01	N/A	-S-XXX-01-02	-S-XXX-02-02	N/A	N/A	-T-XXX-03-01	-S-XXX-03-02	N/A	
		3	1	N-1	B20	N/A	-T-XXX-01-01	-T-XXX-02-01	N/A	-S-XXX-02-02	N/A	N/A	-S-XXX-01-02	-T-XXX-03-01	N/A	N/A	-S-XXX-03-02	
		4	1	N	B20	N/A	-T-XXX-01-02	-T-XXX-02-02	N/A	-S-XXX-02-01	N/A	N/A	-S-XXX-01-01	-T-XXX-03-02	N/A	N/A	-S-XXX-03-01	
-TPD	-T-XXX-03-01	1	1	1	T1	N/A	-T-XXX-01-02	-T-XXX-02-02	N/A	-S-XXX-02-01	N/A	N/A	-S-XXX-01-01	-T-XXX-03-02	N/A	N/A	-S-XXX-03-01	
		2	1	2	T1	N/A	-T-XXX-01-01	-T-XXX-02-01	N/A	-S-XXX-02-02	N/A	N/A	-S-XXX-01-02	-T-XXX-03-01	N/A	N/A	-S-XXX-03-02	
		3	1	N-1	T1	-T-XXX-02-01	N/A	N/A	-T-XXX-01-01	N/A	-S-XXX-01-02	-S-XXX-02-02	N/A	N/A	-T-XXX-03-01	-S-XXX-03-02	N/A	
		4	1	N	T1	-T-XXX-02-02	N/A	N/A	-T-XXX-01-02	N/A	-S-XXX-01-01	-S-XXX-02-01	N/A	N/A	-T-XXX-03-02	-S-XXX-03-01	N/A	
-SPU	-S-XXX-03-01	1	1	1	B1	N/A	-T-XXX-01-01	-T-XXX-02-01	N/A	-S-XXX-02-02	N/A	N/A	-S-XXX-01-02	-T-XXX-03-01	N/A	N/A	-S-XXX-03-02	
		2	1	2	B1	N/A	-T-XXX-01-02	-T-XXX-02-02	N/A	-S-XXX-02-01	N/A	N/A	-S-XXX-01-01	-T-XXX-03-02	N/A	N/A	-S-XXX-03-01	
		3	1	N-1	B1	-T-XXX-02-02	N/A	N/A	-T-XXX-01-02	N/A	-S-XXX-01-01	-S-XXX-02-01	N/A	N/A	-T-XXX-03-02	-S-XXX-03-01	N/A	
		4	1	N	B1	-T-XXX-02-01	N/A	N/A	-T-XXX-01-01	N/A	-S-XXX-01-02	-S-XXX-02-02	N/A	N/A	-T-XXX-03-01	-S-XXX-03-02	N/A	
-SPD	-S-XXX-03-01	1	1	1	T20	-T-XXX-02-01	N/A	N/A	-T-XXX-01-01	N/A	-S-XXX-01-02	-S-XXX-02-02	N/A	N/A	-T-XXX-03-01	-S-XXX-03-02	N/A	
		2	1	2	T20	-T-XXX-02-02	N/A	N/A	-T-XXX-01-02	N/A	-S-XXX-01-01	-S-XXX-02-01	N/A	N/A	-T-XXX-03-02	-S-XXX-03-01	N/A	
		3	1	N-1	T20	N/A	-T-XXX-01-02	-T-XXX-02-02	N/A	-S-XXX-02-01	N/A	N/A	-S-XXX-01-01	-T-XXX-03-02	N/A	N/A	-S-XXX-03-01	
		4	1	N	T20	N/A	-T-XXX-01-01	-T-XXX-02-01	N/A	-S-XXX-02-02	N/A	N/A	-S-XXX-01-02	-T-XXX-03-01	N/A	N/A	-S-XXX-03-02	

FOR RT1 OPTION SUB ASSEMBLY ADD -RT1 TO THE END OF THE SUB ASSEMBLY
CALLOUT LISTED IN THE TABLE ABOVE.

PROPRIETARY NOTE

THIS DOCUMENT CONTAINS INFORMATION
CONFIDENTIAL AND PROPRIETARY TO
SAMTEC, INC. AND SHALL NOT BE REPRODUCED
OR TRANSFERRED TO OTHER DOCUMENTS OR
DISCLOSED TO OTHERS OR USED FOR ANY
PURPOSE OTHER THAN THAT WHICH IT WAS
OBTAINED WITHOUT THE EXPRESSED WRITTEN
CONSENT OF SAMTEC, INC.

DO NOT SCALE DRAWING

SHEET SCALE: 1:25:1



520 PARK EAST BLVD, NEW ALBANY, IN 47150
PHONE: 812-944-6733 FAX: 812-948-5047
e-Mail: info@SAMTEC.com code: 55322

DESCRIPTION:
0.8mm HIGH-SPEED COAX CABLE ASSEMBLY

DWG. NO.
EQCD-XXX-XX.XX-XXX-XXX-X-X

BY: KEVIN B 02/19/03 SHEET 7 OF 7