

MABA-011002



4:1 Step Down Transformer
5 - 200 MHz

Rev. V1

Features

- Surface Mount
- 4:1 Step Down Transformer
- Excellent performance under DC bias current, even when current flows is imbalanced out outputs
- 260°C Reflow Compatible
- RoHS* Compliant, lead free
- Available on Tape and Reel.

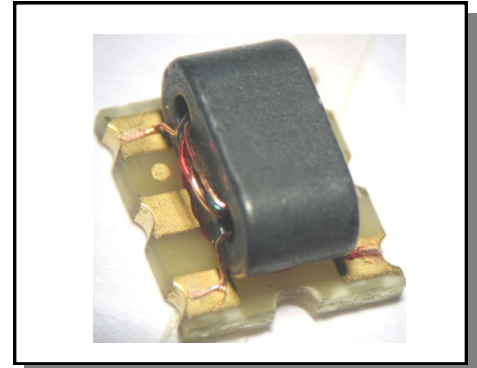

Electrical Specifications: $Z_0 = 75\Omega$, $T_A = 25^\circ\text{C}$, $P_{in} = 0\text{dBm}$

Parameter	Conditions	Units	Min	Typ	Max
Insertion Loss 1 (pin6-pin1)	5 - 50 MHz	dB	-	0.4	0.8
	50 - 150 MHz	dB	-	1.0	2.2
	150 - 200 MHz	dB	-	2.0	3.1
Insertion Loss 2 (pin6-pin3)	5 - 50 MHz	dB	-	0.4	0.8
	50 - 150 MHz	dB	-	1.1	2.5
	150 - 200 MHz	dB	-	2.4	3.6
Amplitude Balance	5 - 50 MHz	dB	-	0.0	± 0.4
	50 - 150 MHz	dB	-	0.0	± 1.0
	150 - 200 MHz	dB	-	0.3	± 1.4
Phase Balance	5 - 50 MHz	$^\circ$	-	0.6	± 4
	50 - 200 MHz	$^\circ$	-	0.8	± 9
Input Return Loss (pin6)	5 - 25 MHz	dB	17	20	-
	25 - 50 MHz	dB	12	15	-
	50 - 150 MHz	dB	5	9	-
	150 - 200 MHz	dB	3	5	-

Schematic

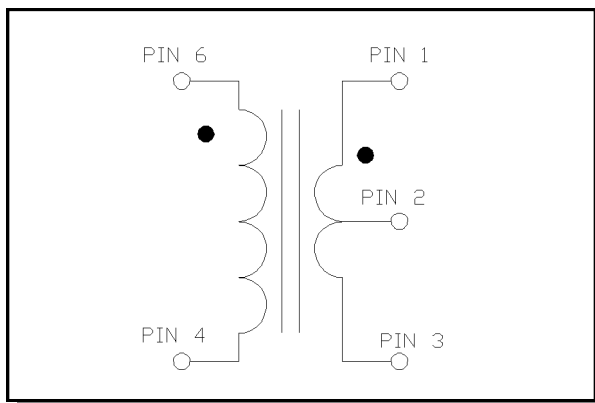

Pin Configuration

Pin No.	Function
1	Secondary Dot (output1)
2	Ground (center tap)
3	Secondary (output2)
4	Primary (RF ground)
5	Ground (not used)
6	Primary dot (input)

1

ADVANCED: Data Sheets contain information regarding a product M/A-COM Technology Solutions is considering for development. Performance is based on target specifications, simulated results, and/or prototype measurements. Commitment to develop is not guaranteed.

PRELIMINARY: Data Sheets contain information regarding a product M/A-COM Technology Solutions has under development. Performance is based on engineering tests. Specifications are typical. Mechanical outline has been fixed. Engineering samples and/or test data may be available. Commitment to produce in volume is not guaranteed.

• **North America** Tel: 800.366.2266 • **Europe** Tel: +353.21.244.6400
• **India** Tel: +91.80.43537383 • **China** Tel: +86.21.2407.1588

Visit www.macomtech.com for additional data sheets and product information.

M/A-COM Technology Solutions Inc. and its affiliates reserve the right to make changes to the product(s) or information contained herein without notice.

MABA-011002



4:1 Step Down Transformer
5 - 200 MHz

Rev. V1

Electrical Specifications: $Z_0 = 75\Omega$, $T_A = 25^\circ\text{C}$, $P_{in} = 0\text{dBm}$

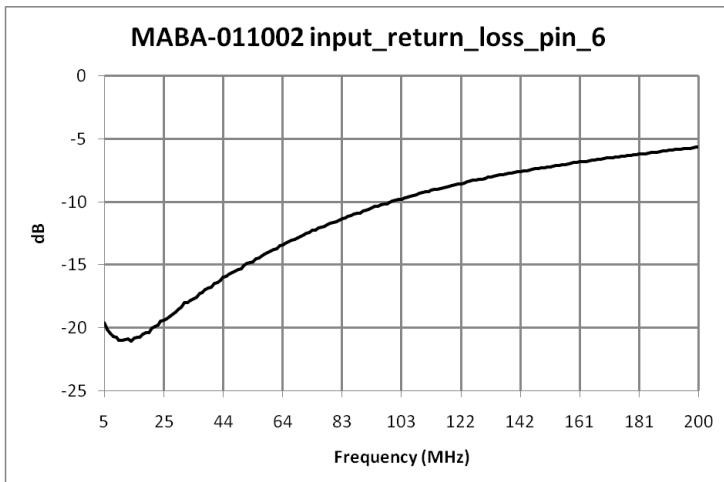
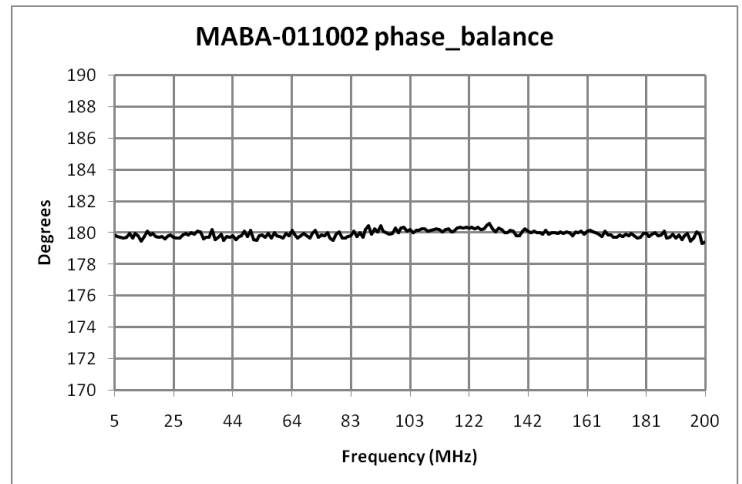
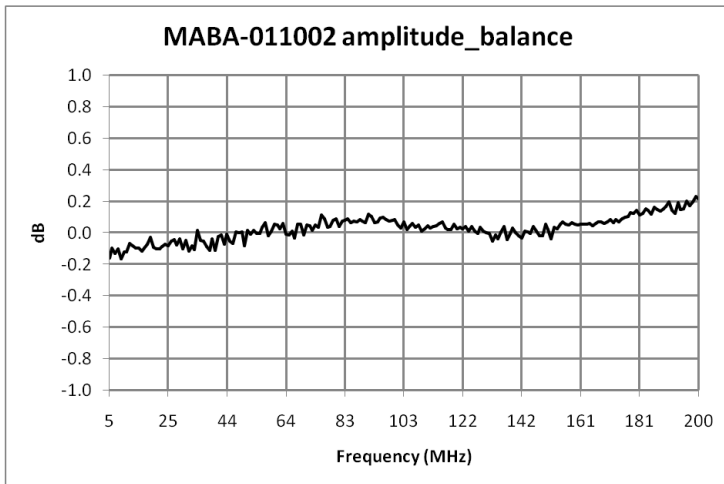
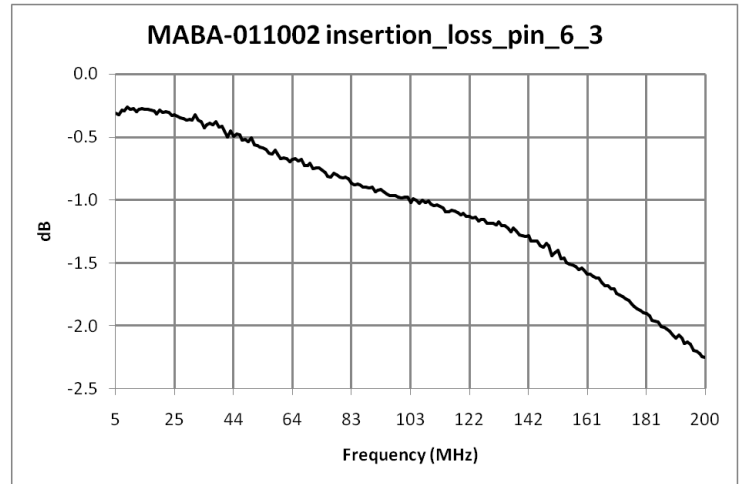
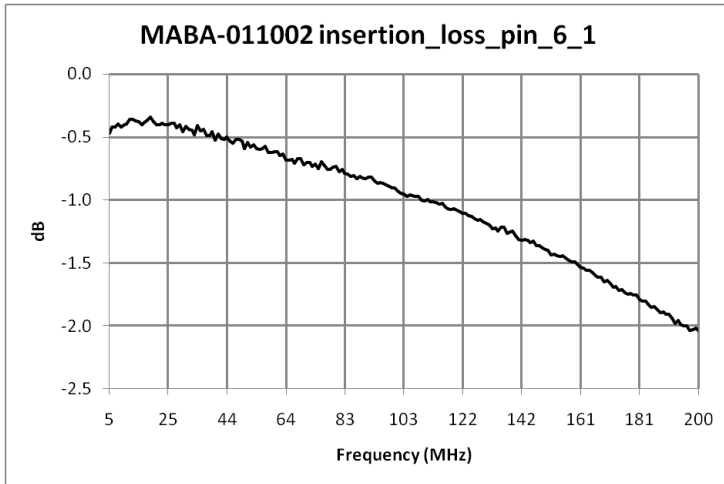

ADVANCED: Data Sheets contain information regarding a product M/A-COM Technology Solutions is considering for development. Performance is based on target specifications, simulated results, and/or prototype measurements. Commitment to develop is not guaranteed.
PRELIMINARY: Data Sheets contain information regarding a product M/A-COM Technology Solutions has under development. Performance is based on engineering tests. Specifications are typical. Mechanical outline has been fixed. Engineering samples and/or test data may be available. Commitment to produce in volume is not guaranteed.

• **North America** Tel: 800.366.2266 • **Europe** Tel: +353.21.244.6400
• **India** Tel: +91.80.43537383 • **China** Tel: +86.21.2407.1588
Visit www.macomtech.com for additional data sheets and product information.

M/A-COM Technology Solutions Inc. and its affiliates reserve the right to make changes to the product(s) or information contained herein without notice.

MABA-011002



4:1 Step Down Transformer
5 - 200 MHz

Rev. V1

Outline Drawing

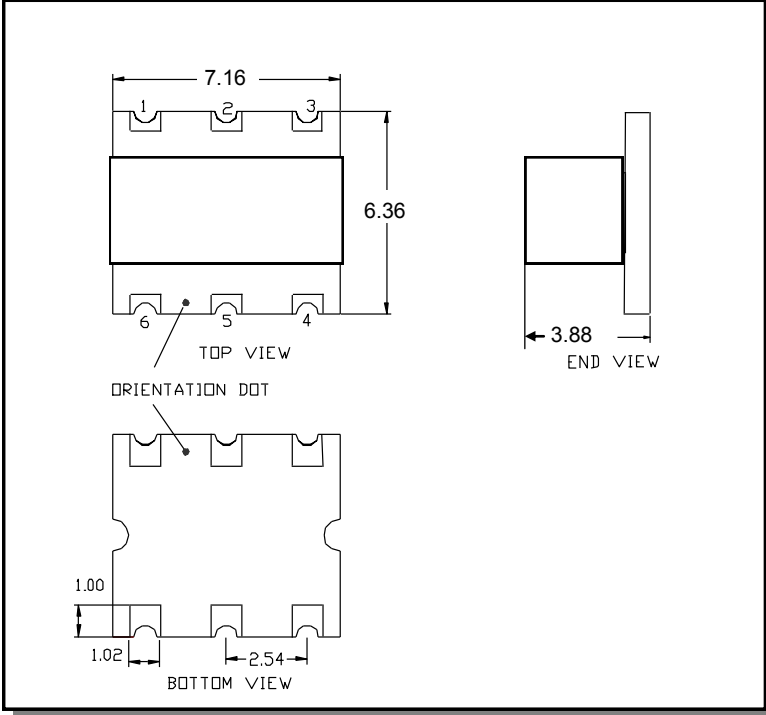

Dimensions in mm Tolerance: .xx ± .30, .xxx ± .030, unless otherwise stated

Recommended Footprint

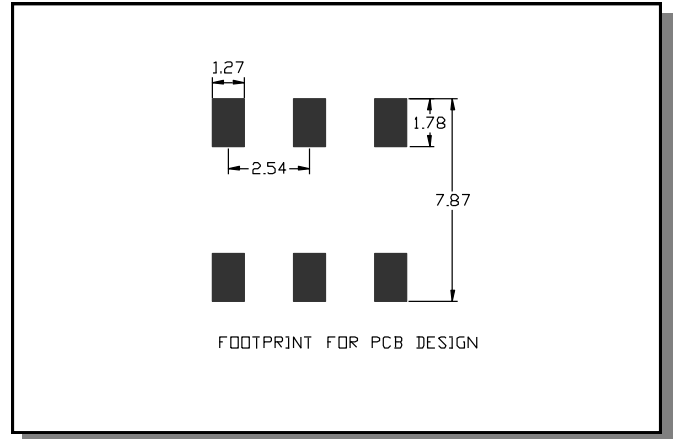

Application Circuit

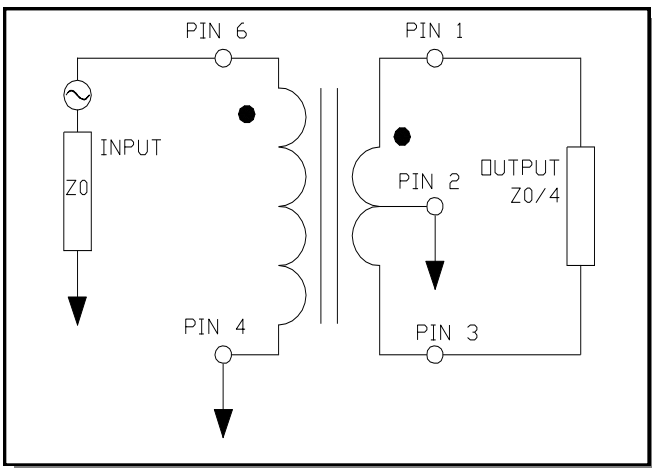

MABA-011002



4:1 Step Down Transformer
5 - 200 MHz

Rev. V1

Tape & Reel Information

Parameter	Units	Value
Qty per reel	-	900
Reel Size	mm	330
Tape Width	mm	16.00
Pitch	mm	12.00
Ao	mm	6.60
Bo	mm	7.40
Ko	mm	4.10
Orientation	-	F38

Reference Application Note ANI-019 for orientation

Ordering Information

Part Number	Description
MABA-011002	Tape & Reel
MABA-011002-TB	Customer Evaluation Board

Recommended Maximum Ratings

Parameter	Units	Min	Max
Input Power	W		1
Internal Load Dissipation	W		0.125
Tested up to DC bias current, will perform above this level	mA		900
Operating Temperature Range	°C	-40	+85

Full temperature plots available on request