



QUICKSWITCH® PRODUCTS
HIGH-SPEED CMOS
20-BIT BUS EXCHANGE SWITCH

IDTQS32X383

FEATURES:

- Enhanced N channel FET with no inherent diode to Vcc
- 5Ω bidirectional switches connect inputs to outputs
- Zero propagation delay
- Zero ground bounce
- Undershoot clamp diodes on all switch and control pins
- 20-bit Double-Width format
- Bus exchange allows nibble swap
- Zero ground bounce in flow-through mode
- TTL-compatible input and output levels
- Available in 48-pin QVSOP Package (Q1)

APPLICATIONS

- Resource sharing
- Crossbar switching
- Hot-docking
- Voltage translation (5V to 3.3V)

DESCRIPTION:

The QS32X383 provides two sets of ten high-speed CMOS TTL-compatible bus switches. The low ON resistance (5Ω) of the QS32X383 allows inputs to be connected to outputs without adding propagation delay and without generating additional ground bounce noise. The Bus Enable (\overline{BE}) signal turns the switches on. The Bus Exchange (BX) signal provides nibble swap of the AB and CD pairs of signals. This exchange configuration allows byte swapping of buses in systems. It can also be used as a 10-wide 2-to-1 multiplexer and to create low delay barrel shifters, etc.

The QS32X383 is characterized for operation at -40°C to +85°C.

FUNCTIONAL BLOCK DIAGRAM

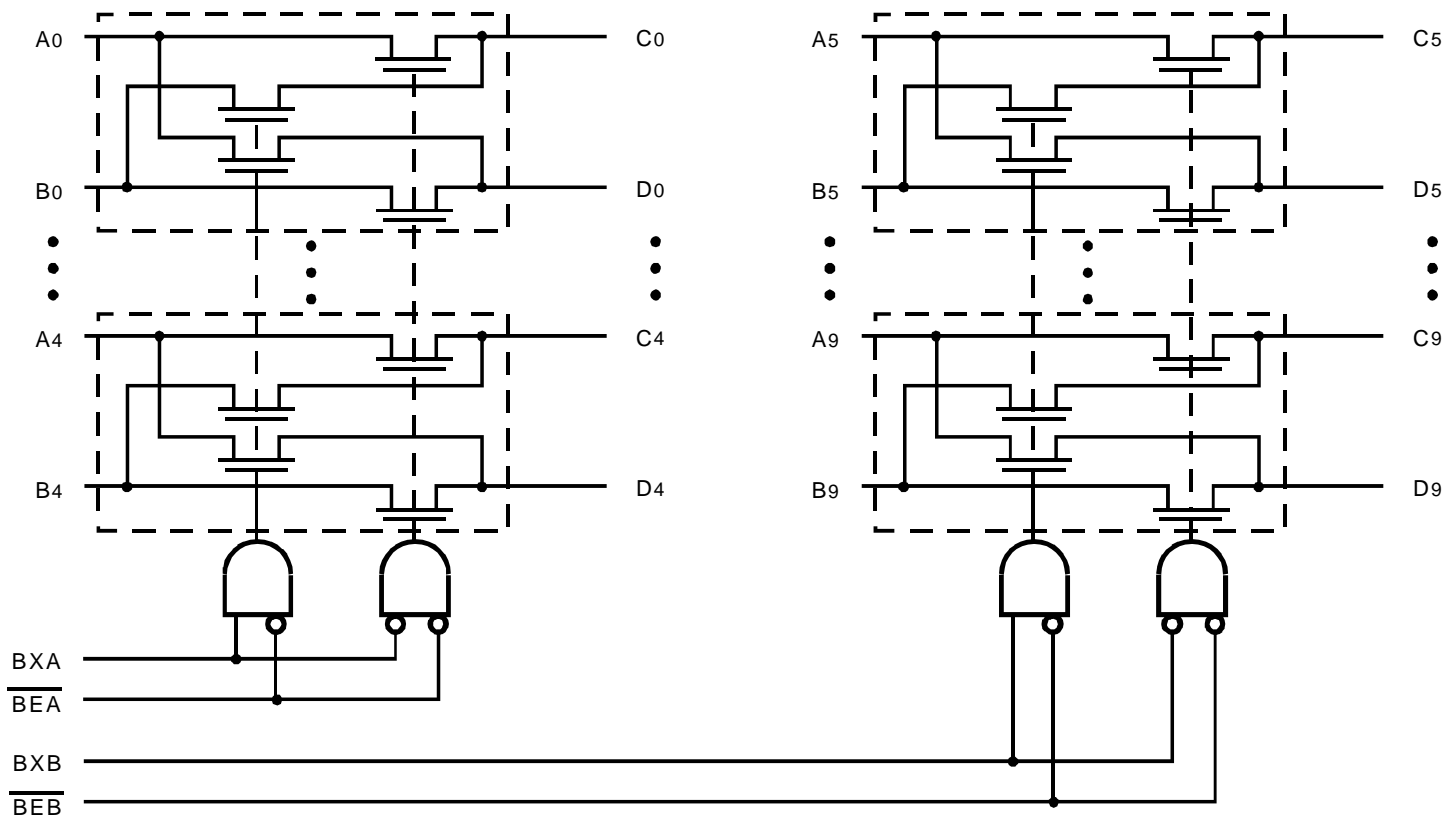

PIN CONFIGURATION

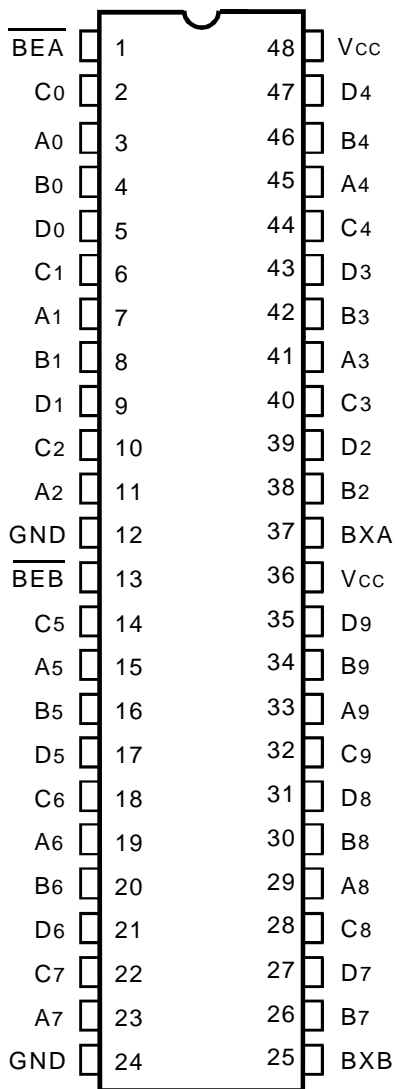

QVSOPTOP VIEW

ABSOLUTE MAXIMUM RATINGS (1)

Symbol	Description	Max.	Unit
VTERM ⁽²⁾	Supply Voltage to Ground	-0.5 to +7	V
VTERM ⁽³⁾	DC Switch Voltage Vs	-0.5 to +7	V
VTERM ⁽³⁾	DC Input Voltage VIN	-0.5 to +7	V
VAC	AC Input Voltage (pulse width ≤20ns)	-3	V
IOUT	DC Output Current	120	mA
PMAX	Maximum Power Dissipation (TA = 85°C)	0.5	W
TSTG	Storage Temperature	-65 to +150	°C

NOTES:

- Stresses greater than those listed under ABSOLUTE MAXIMUM RATINGS may cause permanent damage to the device. This is a stress rating only and functional operation of the device at these or any other conditions above those indicated in the operational sections of this specification is not implied. Exposure to absolute maximum rating conditions for extended periods may affect reliability.
- Vcc Terminals.
- All terminals except Vcc.

CAPACITANCE

(TA = +25°C, f = 1.0MHz, VIN = 0V, VOUT = 0V)

Pins	Typ.	Max. (1)	Unit
Control Inputs	3	5	pF
Quickswitch Channels (Switch OFF)	5	7	pF

NOTE:

- This parameter is guaranteed but not production tested.

PIN DESCRIPTION

Pin Names	I/O	Description
Ax, Bx	I/O	Buses A, B
Cx, Dx	I/O	Buses C, D
$\overline{BE}n$	I	Bus Switch Enable
BXn	I	Bus Exchange

FUNCTION TABLE(1)

$\overline{BE}A$	BXA	A0 - A4	B0 - B4	Function
H	X	Hi-Z	Hi-Z	Disconnect
L	L	C0 - C4	D0 - D4	Connect
L	H	D0 - D4	C0 - C4	Exchange
$\overline{BE}B$	BXB	A5 - A9	B5 - B9	Function
H	X	Hi-Z	Hi-Z	Disconnect
L	L	C5 - C9	D5 - D9	Connect
L	H	D5 - D9	C5 - C9	Exchange

NOTE:

- H = HIGH Voltage Level
L = LOW Voltage Level
X = Don't care
Z = High-Impedence

DC ELECTRICAL CHARACTERISTICS OVER OPERATING RANGE

Following Conditions Apply Unless Otherwise Specified:

Industrial: $T_A = -40^{\circ}\text{C}$ to $+85^{\circ}\text{C}$, $V_{CC} = 5.0\text{V} \pm 5\%$

Symbol	Parameter	Test Conditions	Min.	Typ. ⁽¹⁾	Max.	Unit
V_{IH}	Input HIGH Voltage	Guaranteed Logic HIGH for Control Pins	2	—	—	V
V_{IL}	Input LOW Voltage	Guaranteed Logic LOW for Control Pins	—	—	0.8	V
I_{IN}	Input Leakage Current (Control Inputs)	$0\text{V} \leq V_{IN} \leq V_{CC}$, Control Inputs	—	0.01	± 1	μA
I_{OZ}	Off-State Current (Hi-Z)	$0\text{V} \leq V_{OUT} \leq V_{CC}$, Switches OFF	—	0.01	± 1	μA
R_{ON}	Switch ON Resistance	$V_{CC} = \text{Min.}$, $V_{IN} = 0\text{V}$, $I_{ON} = 30\text{mA}$	—	6	8	Ω
R_{ON}	Switch ON Resistance	$V_{CC} = \text{Min.}$, $V_{IN} = 2.4\text{V}$, $I_{ON} = 15\text{mA}$	—	12	17	Ω
V_P	Pass Voltage ⁽²⁾	$V_{CC} = 5\text{V}$, $I_{OUT} = -5\mu\text{A}$	3.7	4	4.2	V

NOTES:

1. Typical values are at $V_{CC} = 5.0\text{V}$, $T_A = 25^{\circ}\text{C}$.
2. Pass voltage is guaranteed but not production tested.

TYPICAL ON RESISTANCE vs V_{IN} AT $V_{CC} = 5\text{V}$

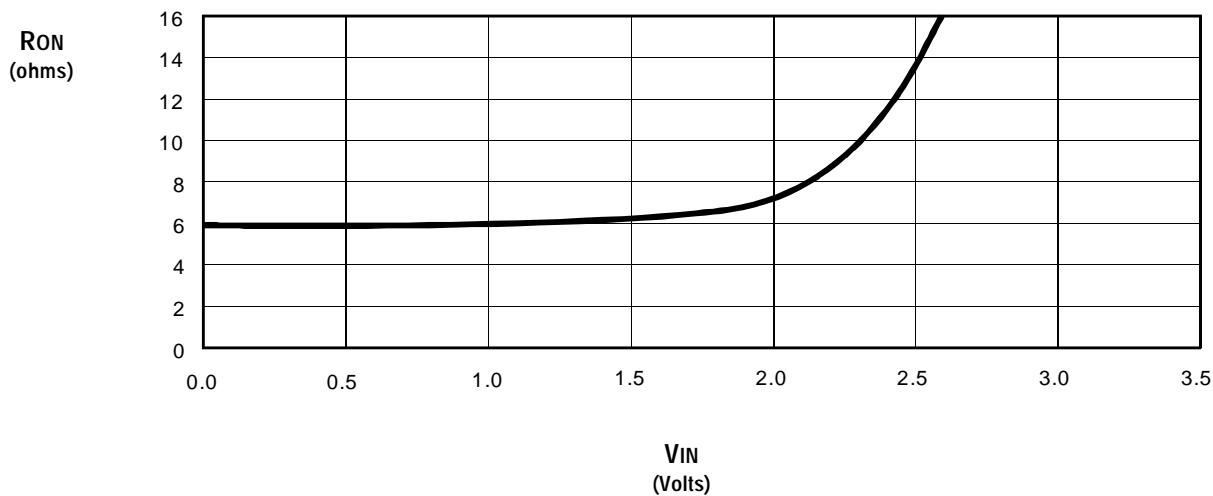

POWER SUPPLY CHARACTERISTICS

Symbol	Parameter	Test Conditions ⁽¹⁾	Max.	Unit
I _{CCQ}	Quiescent Power Supply Current	V _{CC} = Max., V _{IN} = GND or V _{CC} , f = 0	3	mA
ΔI _{CC}	Power Supply Current per Control Input HIGH ⁽²⁾	V _{CC} = Max., V _{IN} = 3.4V, f = 0	2.5	mA
I _{CCD}	Dynamic Power Supply Current per MHz ⁽³⁾	V _{CC} = Max., A and B pins open Control Input Toggling at 50% Duty Cycle	0.25	mA/MHz

NOTES:

- For conditions shown as Min. or Max., use the appropriate values specified under DC Electrical Characteristics.
- Per TLL driven input (V_{IN} = 3.4V, control inputs only). A and B pins do not contribute to ΔI_{CC}.
- This current applies to the control inputs only and represents the current required to switch internal capacitance at the specified frequency. The A and B inputs generate no significant AC or DC currents as they transition. This parameter is guaranteed but not production tested.

SWITCHING CHARACTERISTICS OVER OPERATING RANGE

T_A = -40°C to +85°C, V_{CC} = 5.0V ± 5%

C_{LOAD} = 50pF, R_{LOAD} = 500Ω unless otherwise noted.

Symbol	Parameter	Min. ⁽¹⁾	Typ.	Max.	Unit
t _{PLH} t _{PHL}	Data Propagation Delay ^(2,4) AxBx to CxDx, CxDx to AxBx	—	—	0.25 ⁽³⁾	ns
t _{PZL} t _{PZH}	Switch Turn-on Delay B \bar{E} to Ax, Bx, Cx, Dx	1.5	—	6.5	ns
t _{PLZ} t _{PHZ}	Switch Turn-off Delay ⁽²⁾ B \bar{E} to Ax, Bx, Cx, Dx	1.5	—	5.5	ns
t _{BX} t _{PHZ}	Switch Multiplex Delay ⁽²⁾ BX to Ax, Bx, Cx, Dx	1.5	—	6.5	ns

NOTES:

- Minimums are guaranteed but not production tested.
- This parameter is guaranteed but not production tested.
- The time constant for the switch alone is of the order of 0.25ns for C_L = 50pF.
- The bus switch contributes no propagation delay other than the RC delay of the ON resistance of the switch and the load capacitance. Since this time constant is much smaller than the rise and fall times of typical driving signals, it adds very little propagation delay to the system. Propagation delay of the bus switch, when used in a system, is determined by the driving circuit on the driving side of the switch and its interaction with the load on the driven side.

ORDERING INFORMATION

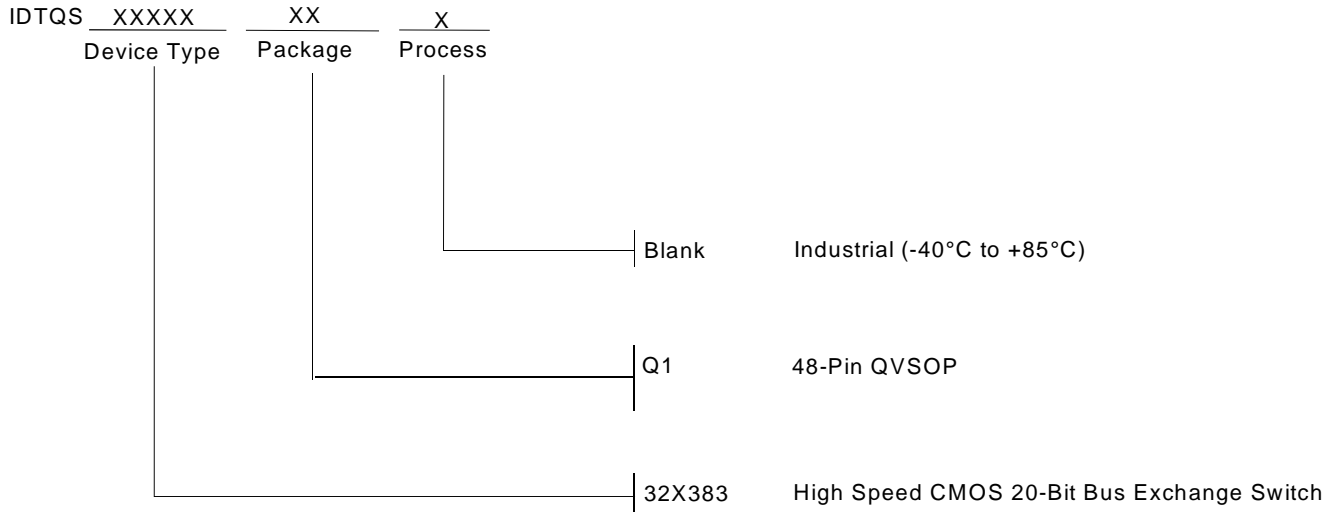

CORPORATE HEADQUARTERS
2975 Stender Way
Santa Clara, CA 95054

for SALES:
800-345-7015 or 408-727-6116
fax: 408-492-8674
www.idt.com*

*To search for sales office near you, please click the sales button found on our home page or dial the 800# above and press 2.
The IDT logo, QuickSwitch, and SynchroSwitch are registered trademarks of Integrated Device Technology, Inc.